

# Versione + Aggiornata

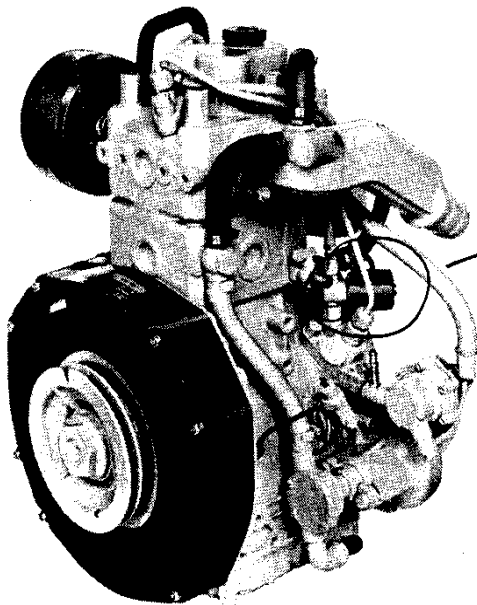

LIBRETTO DI USO E MANUTENZIONI PER MOTORI SERIE  
 USE - MAINTENANCE FOR DIESEL ENGINES SERIE  
 EMPLOI - ENTRETIEN POUR MOTEURS DIESEL SERIE  
 GEBRAUCH - WARTUNG FÜR DIESELMOTOR SERIE

**RM**  
**RDM**



*Fliehkraftregler*

**CARATTERISTICHE:**

Ciclo diesel a 4 tempi • iniezione diretta • raffreddamento ad acqua con circuito aperto • alimentazione con pompa combustibile a membrana • lubrificazione forzata mediante pompa a lobi • regolatore automatico centrifugo a sfere • avviamento elettrico.

**CHARACTERISTICS:**

Four stroke Diesel Cycle • direct injection • water cooling with open circuit • feeding with membrane fuel pump • forced lubrication with oil pump • automatic regulation by centrifugal governor • electric starting.

**CARACTERISTIQUES:**

Diesel 4 temps • injection directe • refroidissement par eau avec circuit ouvert • alimentation avec pompe du combustible à membrane • lubrification forcée avec pompe à lobes • réglage automatique avec régulateur à masses centrifuges • démarrage électrique.

**MERKMALE :**

Viertakt Dieselmotor • Direkte Einspritzung • Kühlung mit Wasser • Brennstoffzufuhr durch Membranpumpe • Gezwungene Schmierung mittels Ölpumpe • Regler: automatischer Fliehkraftregler • Elektro anlasser.

**DATI TECNICI • TECHNICAL DATA • DONNEES TECHNIQUES • TECHNISCHE DATEN**

TIPO - TYPE - TYP - TIPO		RM 80	RM 81	RDM 901	RM 121
Alesaggio - Bore Alésage - Bohrung	mm. (inch).	80 (3.15)		90 (3.54)	
Corsa - Stroke Course - Hub	mm. (inch).	75 (2.95)		85 (3.35)	
Cilindrata - Displacement Cylindrée - Hubraum	cc. (cu. inch.)	377 (23.00)		542 (33.1)	
Potenza - Power Puissance - Leistung	N (DIN 70020) HP (KW)	8,4 (6.2)	8,9 (6.5)	12,2 (9)	12,7 (9.3)
Potenza - Power Puissance - Leistung	NB (DIN 6270) HP (KW)	7,5 (5.5)	8 (5.9)	10,8 (7.9)	11,7 (8.6)
Potenza - Power Puissance - Leistung	NA (DIN 6270) HP (KW)	6,7 (4.9)	7 (5.1)	9,7 (7.1)	10,6 (7.8)
Giri/1 - R.P.M. Tours/mn. - U/min.		3000	3600	3000	3600
Coppia max. - Max. torque Couple max. - Höchst Drehmoment	Kgm (ft. lbs)	2,15 (15.5)		3,1 (22.4)	
Rapporto compress. - Compress. ratio Rapport compress. - Verdichtungsverhältnis		19,3:1		18,2:1	
Numero cilindri - Number of cylinders Nombre cylindres - Anzahl Zylinder		1			
Capacità olio basamento - Oil sump capacity Capacité huile carter - Schmierölfüllung		1.8 Kg. (3.97 lbs) (2 liters) (0.528 U.S. gall.)			
Peso a secco - Dry weight Poids à vide - Trockengewicht.	Kg. (lbs)	62 (136.6)		68 (149.9)	

**RUGGERINI motori**

Stabilimento e uffici: 42100 Via Cartasio, 39  
 Villa Bagno (Reggio Emilia) - Tel. 583221 - Telex 530321 Motrug-I



**BASAMENTO - CARTER MOTEUR  
CRANKCASE - KURBELGEHÄUSE**

CATALOGO RICAMBI SPARE PARTS		
TAVOLA TABLE	1	1
DATA DATE	5 / 89	

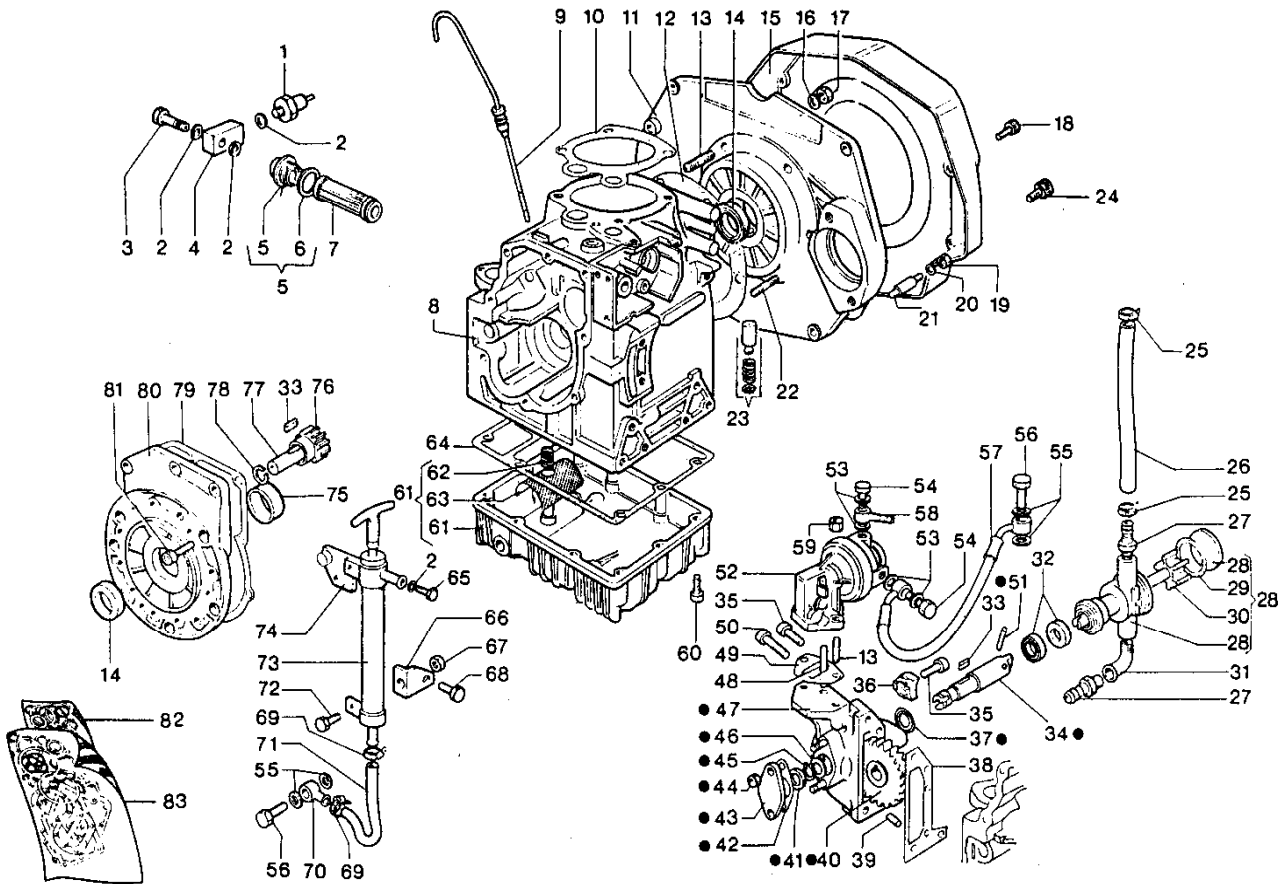

Nr. No.	CODICE CODE	DENOMINAZIONE - DENOMINATION - DESCRIPTION - BENENNUNG				Q.
1	674 - 01	Pressostato	Mano-contact-press.	Pressure switch	Druckschalter	1
2	754 - 02	Rondella	Rondelle	Washer	Unterlegscheibe	3
3	716 - 62	Raccordo	Raccord	Union	Anschlussstück	1
4	612 - 30	Piastrina	Arrêtoir	Safety plate	Sicherungsblech	1
5	A 2144	Tappo filtro olio	Bouchon	Plug	Verschluss	1
6	579 - 72	Anello OR	Bague	Seal ring	Ring	1
7	175 - 05	Cartuccia filtro olio	Cartouche huile	Oil cartridge	Patrone	1
8	168 - 41	Basamento	Carter moteur	Crankcase	Kurbelgehäuse	1
9	076 - 37	Asta livello olio	Jauge	Oil dipstick	Meßstab	1
10	449 - 27	Guarnizione sp. 0,1 mm.	Joint	Gasket	Dichtung	2
	449 - 28	Guarnizione sp. 0,2 mm.	Joint	Gasket	Dichtung	2
11	878 - 45	Supporto RM80-81-90-91	Support	Support	Lager	1
	876 - 56	Supporto RDM901 - RM121	Support	Support	Lager	1
12	448 - 69	Guarnizione sp. 0,1 mm.	Joint	Gasket	Dichtung	1
	448 - 67	Guarnizione sp. 0,2 mm.	Joint	Gasket	Dichtung	1
	447 - 74	Guarnizione sp. 0,3 mm.	Joint	Gasket	Dichtung	1
13	676 - 02	Prigioniero	Goujon	Stud	Stiftschraube	4
14	2118	Anello tenuta olio	Bague étanchéité	Oil seals	Dichtring	1
15	171 - 27	Protezione volano RM 80-81-90	Protection	Guard	Schutz	1
	171 - 32	Protezione volano RDM901-RM121	Protection	Guard	Schutz	1
16	771 - 09	Rondella	Rondelle	Washer	Unterlegscheibe	6
17	323 - 03	Dado	Ecrou	Nut	Mutter	6
18	992 - 68	Vite RDM901-RM121	Vis	Screw	Schraube	3
19	323 - 76	Dado RM 80-81-90	Ecrou	Nut	Mutter	7
20	771 - 51	Rondella RM 80-81-90	Rondelle	Washer	Unterlegscheibe	7
21	354 - 37	Prigioniero RM 80-81-90	Goujon	Stud	Stiftschraube	7
22	676 - 70	Prigioniero	Goujon	Stud	Stiftschraube	4
23	2126	Valvola by-pass compl.	Soupape huile	Oil valve	Ölüberdruckventil	1
24	992 - 67	Vite RDM901-RM121	Vis	Screw	Schraube	1
25	375 - 58	Fascetta	Collier	Clamp	Rohrschelle	2
26	930 - 77	Tubo RM 80-81-90	Tuyau	Pipe	Rohr	1
	930 - 97	Tubo RDM901 - RM121	Tuyau	Pipe	Rohr	1
27	716 - 93	Raccordo	Raccord	Union	Anschlussstück	2
28	652 - 32	Pompa acqua completa	Pompe à eau	Water pump	Wasser pump	1
29	449 - 65	Guarnizione	Joint	Gasket	Dichtung	1
30	439 - 17	Girante	Turbine	Impeller	Laufrad	1
31	717 - 41	Raccordo a gomito	Raccord	Union	Anschlussstück	1
32	054 - 38	Anello tenuta olio	Bague étanchéité	Oil seals	Dichtring	2
33	498 - 15	Linguetta	Clavette	Key	Keil	2



## BASAMENTO - CARTER MOTEUR CRANKCASE - KURBELGEHÄUSE

CATALOGO RICAMBI SPARE PARTS		
TAVOLA TABLE	1	2
DATA DATE	5 / 89	

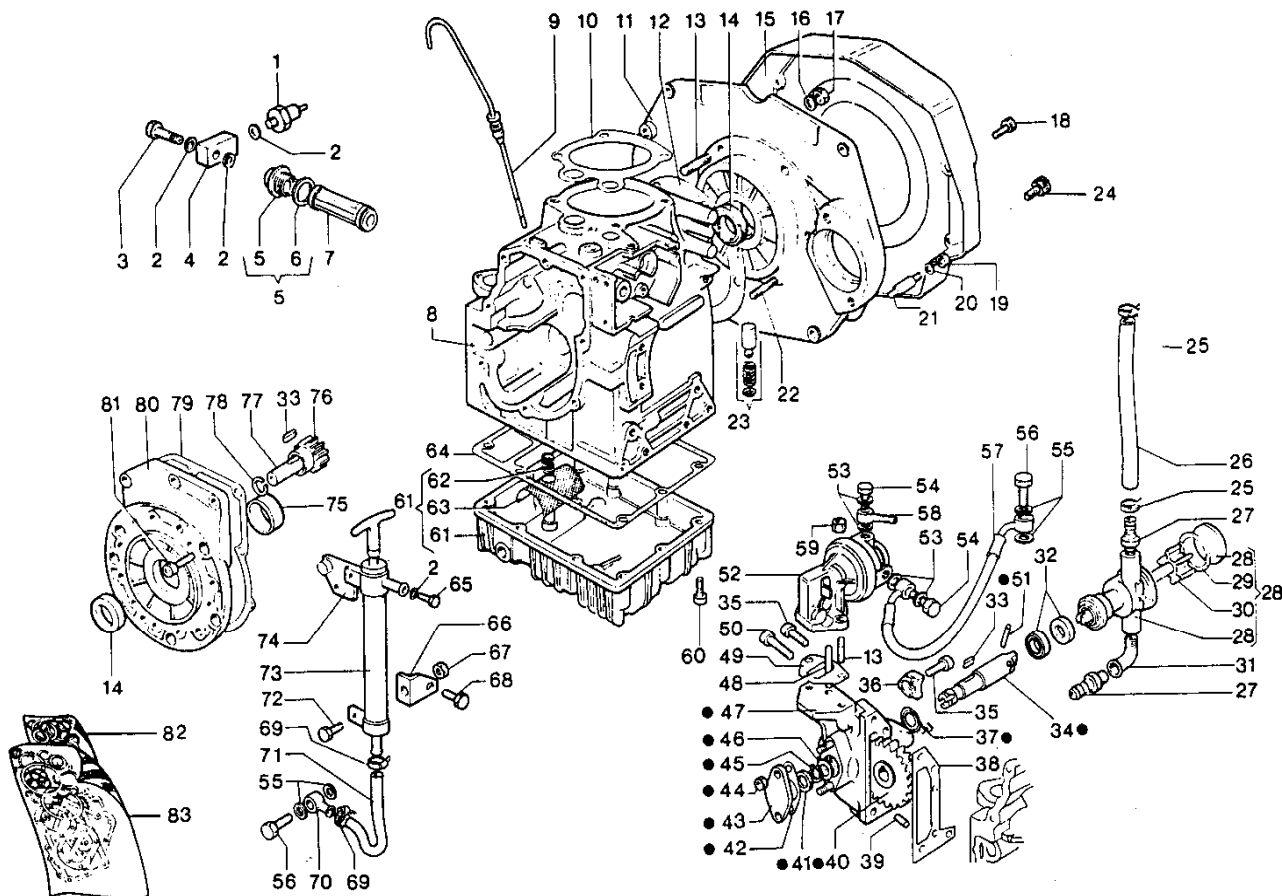

Nr. No.	CODICE CODE	DENOMINAZIONE - DENOMINATION - DESCRIPTION - BENENNUNG				Q.
34	601 - 79	Perno	Axe	Shaft	Zapfen	1
35	992 - 12	Vite	Vis	Screw	Schraube	4
36	858 - 68	Staffa fiss. pompa	Etrier	Brace	Bügel	2
37	579 - 58	Anello OR	Bague	Ring	Ring	1
38	447 - 91	Guarnizione	Joint	Gasket	Dichtung	1
39	841 - 24	Spina cilindrica	Goupille	Pin	Kegelstift	2
40	468 - 54	Ingranaggio	Engrenage	Gear	Zahnrad	1
41	042 - 04	Anello centraggio	Bague	Ring	Ring	1
42	449 - 61	Guarnizione	Joint	Gasket	Dichtung	1
43	231 - 95	Coperchio	Couvercle	Cover	Deckel	1
44	323 - 09	Dado	Ecrou	Nut	Mutter	2
45	046 - 13	Anello seeger	Circlip	Snap ring	Sicherungsring	1
46	777 - 13	Rondella rasamento	Rondella	Washer	Unterlegscheibe	1
47	879 - 44	Supporto	Support	Support	Lager	1
48	704 - 10	Puntalino	Poussoir	Drive rod	Betätigungsstange	1
49	450 - 77	Guarnizione	Joint	Gasket	Dichtung	1
	450 - 75	Guarnizione sp. 0,2 mm.	Joint	Gasket	Dichtung	2
50	992 - 35	Vite	Vis	Screw	Schraube	2
51	850 - 43	Spina	Goupille	Pin	Kegelstift	1
52	652 - 12	Pompa aliment. RM 80-81-90	Pompe combustible	Fuel feeding pump	Kraftstoffpumpe	1
	652 - 11	Pompa alim. RDM901-RM121	Pompe combustible	Fuel feeding pump	Kraftstoffpumpe	1
53	754 - 09	Rondella	Rondelle	Washer	Unterlegscheibe	4
54	716 - 25	Raccordo	Raccord	Union	Anschlussstück	2
55	754 - 01	Rondella	Rondelle	Washer	Unterlegscheibe	4
56	716 - 15	Raccordo	Raccord	Union	Anschlussstück	2
57	935 - 49	Tubo RM80-81-90-91	Tuyau	Pipe	Rohr	1
	935 - 68	Tubo RDM901 - RM121	Tuyau	Pipe	Rohr	1
58	575 - 14	Occhiello	Oeillet	Eye	Öse	1
59	325 - 95	Dado	Ecrou	Nut	Mutter	2
60	995 - 11	Vite	Vis	Screw	Schraube	10
61	2124	Coppa olio compl.	Carter huile	Oil sump	Ölsumpf	1
62	540 - 25	Molla	Ressort	Spring	Feder	1
63	734 - 35	Rete	Grille	Net	Netz	1
64	447 - 76	Guarnizione	Joint	Gasket	Dichtung	1
65	993 - 31	Vite	Vis	Screw	Schraube	1
66	612 - 55	Piastrina	Arrâtoir	Safety plate	Sicherungsblech	1
67	323 - 77	Dado	Ecrou	Nut	Mutter	1
68	993 - 25	Vite	Vis	Screw	Schraube	2
69	375 - 58	Fascetta	Collier	Clamp	Rohrschelle	2
70	930 - 25	Tubo con occhio	Tuyau	Pipe	Rohr	1



**BASAMENTO - CARTER MOTEUR  
CRANKCASE - KURBELGEHÄUSER**

CATALOGO RICAMBI  
SPARE PARTS

TAVOLA  
TABLE 1 3

DATA  
DATE 5 / 89

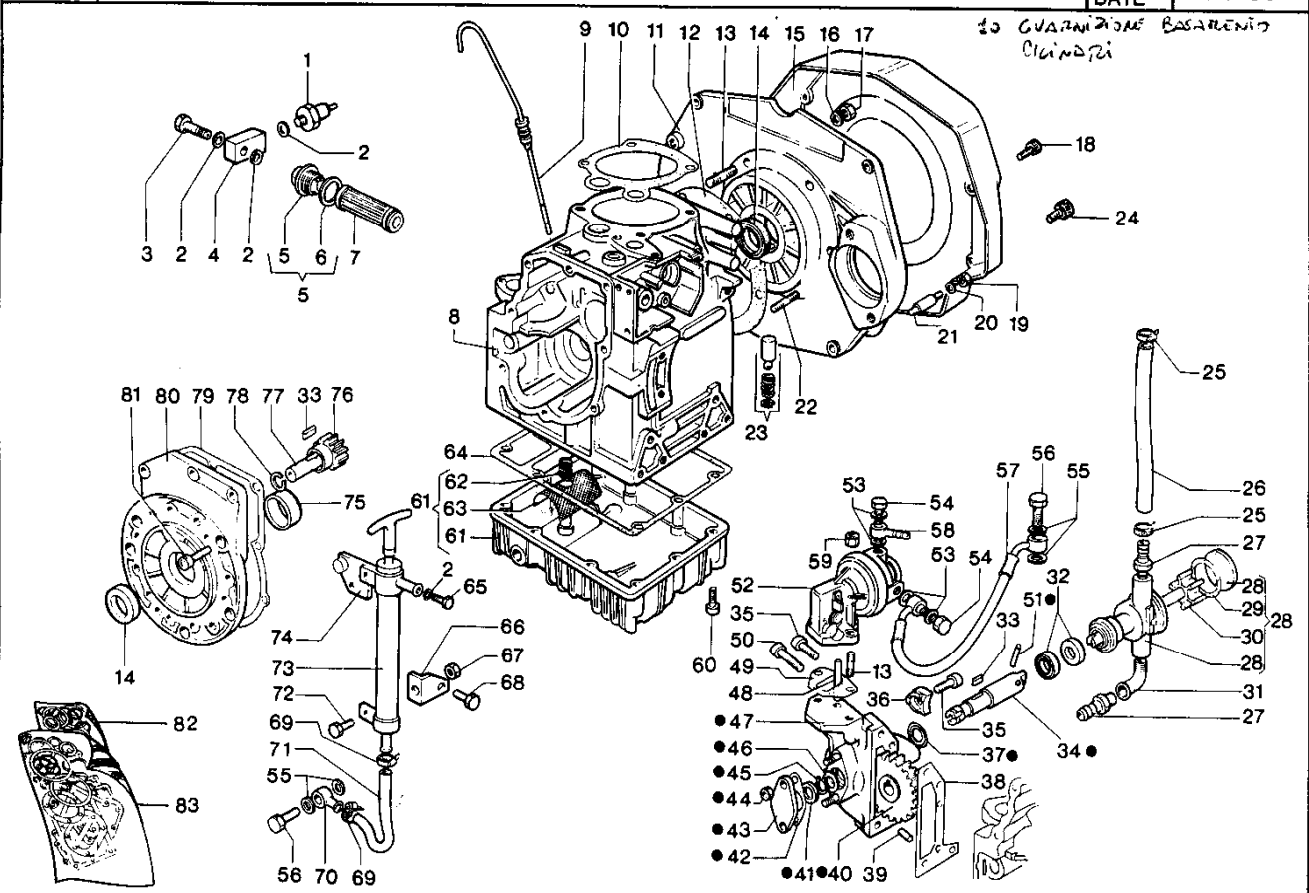

Nr. No.	CODICE CODE	DENOMINAZIONE - DENOMINATION - DESCRIPTION - BENENNUNG				Q.
71	930 - 24	Tubo	Tuyau	Pipe	Rohr	1
72	993 - 68	Vite	Vis	Screw	Schraube	2
73	652 - 07	Pompa estrazione olio	Pompe huile	Oil pump	Pumpe	1
74	612 - 54	Piastrina	Arrêtoir	Safety plate	Sicherungsblech	1
75	310 - 65	Cuscinetto RDM901 - RM121	Coussinet	Bearing	Hauptlager	1
76	468 - 35	Ingranaggio ozioso	Engrenage	Gear	Zahnrad	1
77	600 - 39	Perno	Axe	Shaft	Zapfen	1
78	059 - 08	Anello spallamento	Bague d'entretoise	Spacer ring	Abstandsring	1
79	447 - 75	Guarnizione	Joint	Gasket	Dichtung	1
80	240 - 16	Coperchio distrib. RM 80-90	Couvercle	Cover	Deckel	1
81	240 - 28	Coperc. distrib. RDM901-RM121	Couvercle	Cover	Deckel	1
82	992 - 44	Vite	Vis	Screw	Schraube	8
83	A2026	Guarniz. smerig. RM 80-81	Joint	Overhauling gasket	Dichtung	1
■	2420	Guarniz. smerig. RDM901-RM121	Joint	Overhauling gasket	Dichtung	1
■	A2165	Guarniz. smerig. RM90-RDM901	Joint	Overhauling gasket	Dichtung	1
■	A2027	Guarniz. compl. RM 80-81	Joint	Complete gasket	Dichtung	1
■	2419	Guarniz. compl. RDM901-RM121	Joint	Complete gasket	Dichtung	1
■	*A2166	Guarniz. compl. RM90-RDM901	Joint	Complete gasket	Dichtung	1
•	A2145	Supporto pompa acqua compl.	Support	Support	Lager	1



MANOVELLISMO - ÉQUIPAGE MOBILE  
CRANK MECHANISM - KURBELGETRIEBE

CATALOGO RICAMBI SPARE PARTS		
TAVOLA TABLE	2	1
DATA DATE	5 / 89	

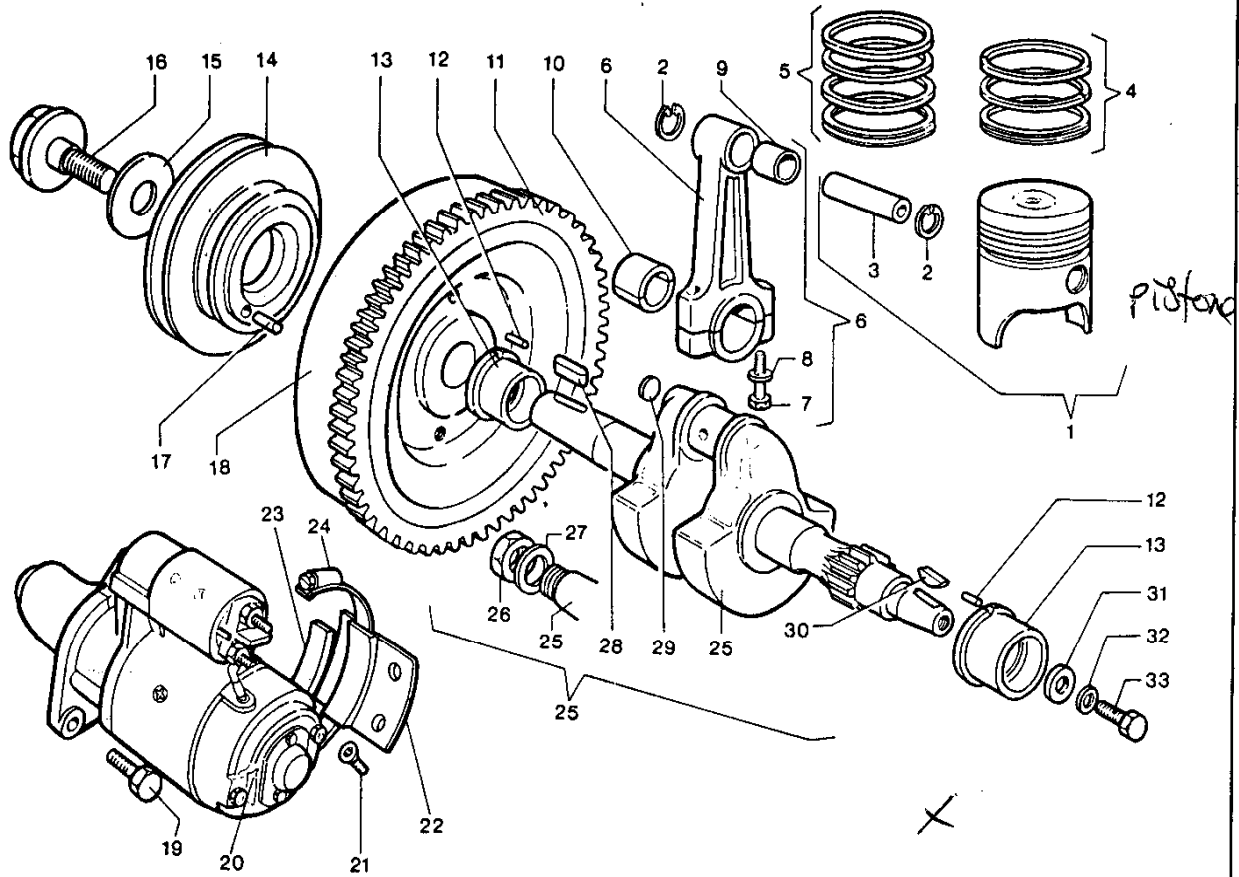

Nr. No.	CODICE CODE	DENOMINAZIONE - DENOMINATION - DESCRIPTION - BENENNUNG				Q.
1	A2018	Pistone Ø 80 mm. RM 80-81	Piston	Piston	Kolben	1
	A2019	Pistone Ø 80,5 mm. RM 80-81	Piston	Piston	Kolben	1
	A2020	Pistone Ø 81 mm. RM 80-81	Piston	Piston	Kolben	1
	A2163 <del>A2245</del>	Pistone Ø 90 mm. RM 90-91	Piston	Piston	Kolben	1
	A2164 <del>A2246</del>	Pistone Ø 90,5 mm. RM 90-91	Piston	Piston	Kolben	1
	A2155 <del>A2247</del>	Pistone Ø 91 mm. RM 90-91	Piston	Piston	Kolben	1
	A2099	Pist. Ø 90 mm. RDM901-RM121	Piston	Piston	Kolben	1
	A2100	Pist. Ø 90,5 mm. RDM901-RM121	Piston	Piston	Kolben	1
	A2101	Pist. Ø 91 mm. RDM901-RM121	Piston	Piston	Kolben	1
	2	050 - 11	Anello seeger RM 80-81	Circlip	Snap ring	Sicherungsring
059 - 81		Anello seeger RM 90-91	Circlip	Snap ring	Sicherungsring	2
050 - 06		Anello seeger RDM901-RM121	Circlip	Snap ring	Sicherungsring	2
3	854 - 12	Spinotto RM 80-81-90-91	Axe	Piston pin	Kolbenbolzen	1
	854 - 11	Spinotto RDM901-RM121	Axe	Piston pin	Kolbenbolzen	1
4	2946	Segmenti Ø 80 mm. RM 80-81	Segments	Pistons rings	Kolbenring	1
	2341	Segmenti Ø 80,5 mm. RM 80-81	Segments	Pistons rings	Kolbenring	1
	2342	Segmenti Ø 81 mm. RM 80-81	Segments	Pistons rings	Kolbenring	1
	A2157	Segmenti Ø 90 mm. RM 90-91	Segments	Pistons rings	Kolbenring	1
	A2158	Segmenti Ø 90,5 mm. RM 90-91	Segments	Pistons rings	Kolbenring	1
	A2159	Segmenti Ø 91 mm. RM 90-91	Segments	Pistons rings	Kolbenring	1
	2149	Segm. Ø 90 mm. RDM901-RM121	Segments	Pistons rings	Kolbenring	1
5	2150	Segm. Ø 90,5 mm. RDM901-RM121	Segments	Pistons rings	Kolbenring	1
	100 <del>2151</del>	Segm. Ø 91 mm. RDM901-RM121	Segments	Pistons rings	Kolbenring	1
	100 - 36	Biella compl. RM 80-81-90-91	Bielle	Connecting rod	Pleuelstange	1
7	100 - 23	Biella compl. RDM901-RM121	Bielle	Connecting rod	Pleuelstange	1
	989 - 22	Vite biella RDM901-RM121	Vis	Screw	Schraube	2
9	989 - 60	Vite biella RM90-91	Vis	Screw	Schraube	2
	316 - 41	Cuscinetto RDM901-RM121	Coussinet	Bearing	Pleuefussbuchse	1
10	316 - 42	Cuscinetto std. RM 80-90	Coussinet	Bearing	Pleuefussbuchse	1
	316 - 50	Cuscinetto -0,25 mm. RM 80-90	Coussinet	Bearing	Pleuefussbuchse	1
	316 - 51	Cuscinetto -0,50 mm. RM 80-90	Coussinet	Bearing	Pleuefussbuchse	1
	316 - 52	Cuscinetto -0,75 mm. RM 80-90	Coussinet	Bearing	Pleuefussbuchse	1
	316 - 36	Cuscinetto std. RDM901-RM121	Coussinet	Bearing	Pleuefussbuchse	1
	316 - 37	Cusc. -0,25 mm. RDM901-RM121	Coussinet	Bearing	Pleuefussbuchse	1
	316 - 38	Cusc. -0,50 mm. RDM901-RM121	Coussinet	Bearing	Pleuefussbuchse	1
	316 - 39	Cusc. -0,75 mm. RDM901-RM121	Coussinet	Bearing	Pleuefussbuchse	1
11	256 - 11	Corona av. RM 80-81-90	Couronne dem.	Starter gear	Starter Kranz	1
	256 - 05	Corona av. RDM901-RM121	Couronne dem.	Starter gear	Starter Kranz	1
12	850 - 10	Spina cilindrica	Goupille	Pin	Kagelstift	1
	310 - 16	Cuscinetto std.	Coussinet	Bearing	Hauptlager	2
13	310 - 17	Cuscinetto -0,25 mm.	Coussinet	Bearing	Hauptlager	2
	310 - 18	Cuscinetto -0,50 mm.	Coussinet	Bearing	Hauptlager	2
	310 - 19	Cuscinetto -0,75 mm.	Coussinet	Bearing	Hauptlager	2
	310 - 53	Cuscinetto +1 mm.	Coussinet	Bearing	Hauptlager	2



1000000000  
1000000000

## MANOVELLISMO - EQUIPAGE MOBILE CRANK MECHANISM - KURBELGETRIEBE

CATALOGO RICAMBI  
SPARE PARTS

TAVOLA  
TABLE

2 2

DATA  
DATE

5 / 89

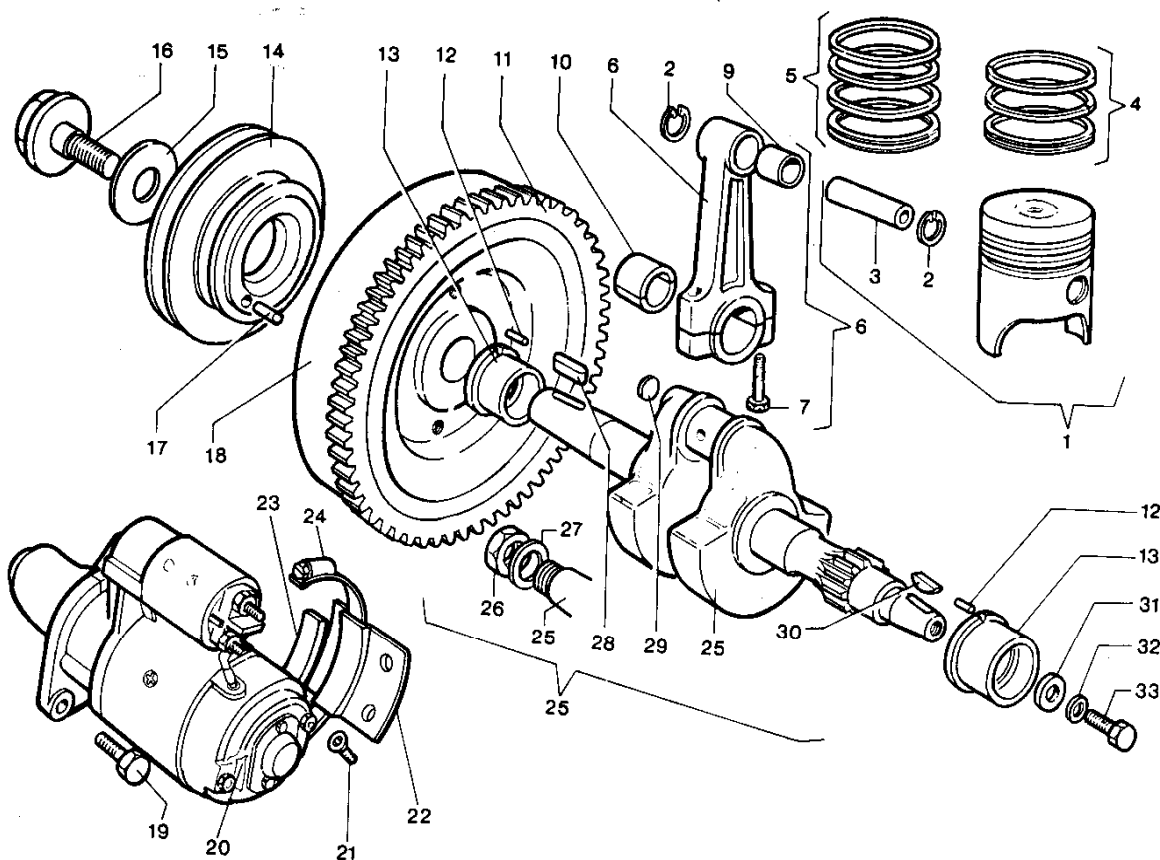

Nr. No.	CODICE CODE	DENOMINAZIONE - DENOMINATION - DESCRIPTION - BENENNUNG				Q.
14	696 - 71	Puleggia avv. RM 80-81-90-91	Poulie	Pulley	Riemenscheibe	1
15	771 - 99	Rondella RM 80-81	Rondelle	Washer	Unterlegscheibe	1
16	116 - 06	Bullone RM 80-81	Boulon	Bolt	Bolzen	1
17	841 - 27	Spina RM 80-81	Goupille	Pin	Kagelstift	1
18	977 - 61	Volano RM 80-81-90-91	Volant	Flywheel	Schwungrad	1
19	976 - 96 992 - 67	Volano RDM901-RM121 Vite	Volant Vis	Flywheel Screw	Schwungrad Schraube	1 2
20	563 - 24	Motorino avv. <i>93202</i>	Démarrreur	Starter	Anlasser	1
21	997 - 42 997 - 82	Vite RM 80-81-90 Vite RDM901-RM121	Vis Vis	Screw Screw	Schraube Schraube	2 2
22	878 - 38 612 - 95	Supporto RM 80-81-90 Supporto RDM901-RM121	Support Support	Support Support	Lager Lager	1 1
23	837 - 29	Spessore RDM901-RM121	Cale	Shim	Unterlegscheibe	1
24	375 - 59	Fascetta	Collier	Clamp	Rohrschelle	2
25	2912 A2054	Albero a gomito RM 80-81-90 Albero a gomito RDM901-RM121	Vilebrequin Vilebrequin	Crankshaft Crankshaft	Kurbelwelle Kurbelwelle	1 1
26	325 - 84	Dado	Ecrou	Nut	Mutter	1
27	771 - 28	Rondella RDM901-RM121	Rondelle	Washer	Unterlegscheibe	1
28	498 - 03	Linguetta	Clavette	Key	Keil	1
29	886 - 04	Tappo	Bouchon	Plug	Verschluss	1
30	498 - 28	Linguetta RM 80-81-90	Clavette	Key	Keil	1
31	771 - 70	Rondella RM 80-81-90	Rondelle	Washer	Unterlegscheibe	1
32	763 - 02	Rondella RM 80-81-90	Rondelle	Washer	Unterlegscheibe	1
33	993 - 01	Vite RM 80-81-90	Vis	Screw	Schraube	1
□	771 - 49	fino al/until 1/10/84 per/for RM 80 matr.0249-400795 - RM 81 matr. 0319-400041				
●		fino al/until 1/10/84 (matr.0249-400795 / 0319-400041) dal/from 1/10/84 vedi/see nr.26				
■	A2025	fino al/until 1/10/84 per/for RM 80 matr.0249-400795 - RM 81 matr. 0319-400041				



**REGOLATORE GIRI - REGULATEUR OF TOURS  
GOVERNOR - REGLER**

CATALOGO RICAMBI SPARE PARTS		
TAVOLA TABLE	3	2
DATA DATE	5 / 89	

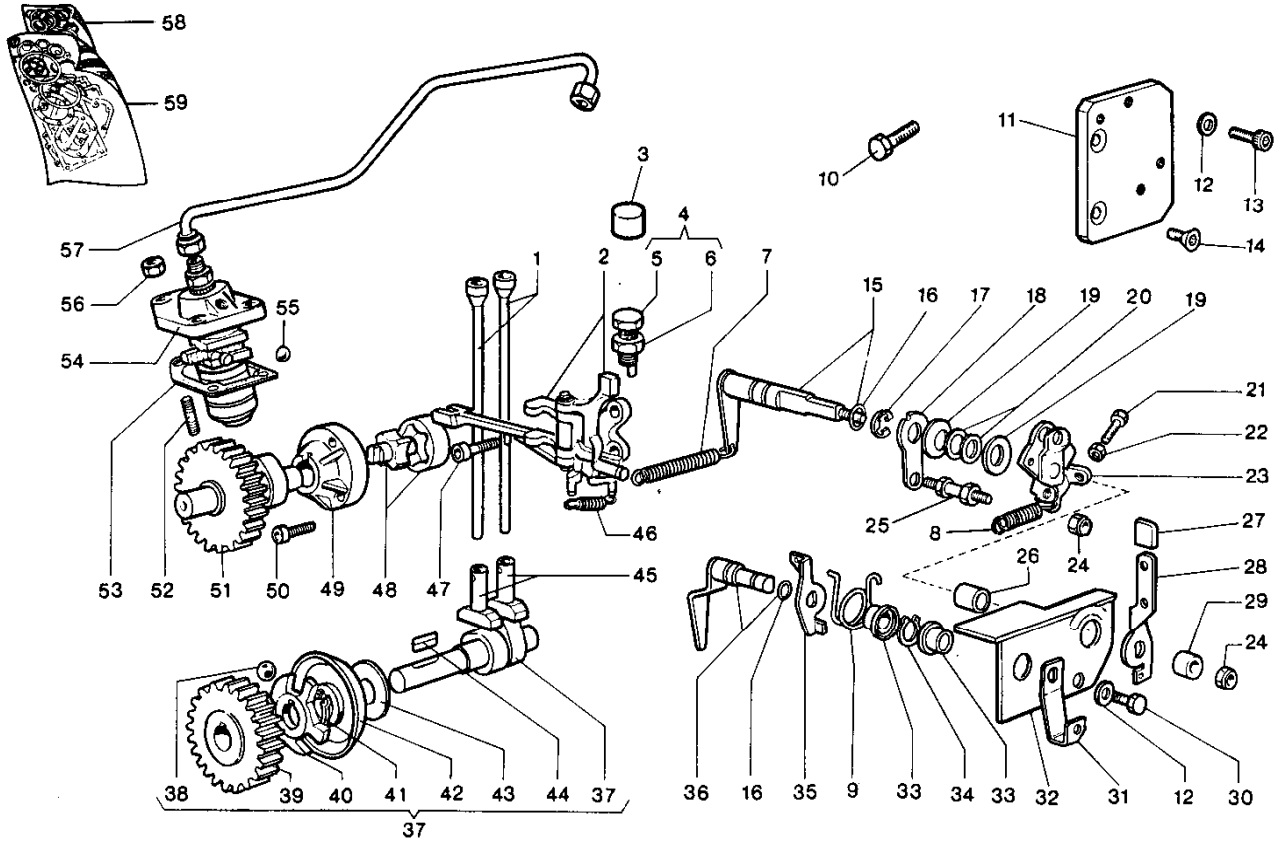

Nr. No.	CODICE CODE	DENOMINAZIONE - DENOMINATION - DESCRIPTION - BENENNUNG				Q.
39	469 - 90	Ingranaggio	Pignon	Gear	Zahnrad	1
	• 468 - 29	Ingranaggio	Pignon	Gear	Zahnrad	1
	• 415 - 08	Gabbia sfere	Cage	Governor cage	Kugelkäfig	1
41	046 - 02	Anello seeger	Circle clip	Snap ring	Sicherungsring	1
	• 621 - 09	Piattello regolatore	Coupelle	Governor plate	Kugelteller	1
	621 - 27	Piattello regolatore	Coupelle	Governor plate	Kugelteller	1
43	777 - 78	Rondella rasamento	Rondelle	Washer	Unteregscheibe	1
44	• 498 - 14	Linguetta	Clavette	Key	Keil	1
45	708 - 16	Punteria	Poussoir	Tappet	Stößel	2
46	551 - 33	Molla	Ressort	Spring	Feder	1
47	992 - 06	Vite	Vis	Screw	Schraube	2
48	2122	Pompa olio completa	Pompe huile	Oil pump	Schmierölpumpe	1
49	231 - 18	Coperchio	Couvercle	Cover	Deckel	1
50	992 - 19	Vite	Vis	Screw	Schraube	3
51	<u>469 - 55</u>	Ingranaggio <i>VR0147020</i>	Pignon	Gear	Zahnrad	1
52	676 - 70	Prigioniero	Goujon	Stud	Stiftschraube	4
53	447 - 65	Guarnizione sp. 0,1 mm.	Joint	Gasket	Dichtung	1
	448 - 66	Guarnizione sp. 0,3 mm.	Joint	Gasket	Dichtung	1
54	656 - 41	Pompa iniezione Omap RM 80-81	Pompe injection	Injection pompe	Enspritzpumpe	1
	656 - 18	Pompa iniez. Bosch RDM901-RM121	Pompe injection	Injection pompe	Einspritzpumpe	1
55	120 - 28	Bussola sferica	Douille	Sleeve	Büchse	1
56	325 - 95	Dado	Ecrou	Nut	Mutter	4
57	944 - 38	Tube iniez. RM 80-81	Tube injection	Injection pipe	Rohr	1
	944 - 59	Tube iniez. RDM901-RM121	Tube injection	Injection pipe	Rohr	1
58	A2026	Guarniz. smerig. RM 80-81	Joint	Overhauling gasket	Dichtung	1
	2420	Guarniz. smerig. RDM901-RM121	Joint	Overhauling gasket	Dichtung	1
59	A2027	Guarniz. compl. RDM 80-81	Joint	Complete gasket	Dichtung	1
	2419	Guarniz. compl. RDM901-RM121	Joint	Complete gasket	Dichtung	1

Fino al 1/3/88 / Untill 1/3/88



**POMPA INIEZIONE E INIETTORE - POMPE A INJECTION - PORTE INJECTEUR  
INJECTION PUMP AND INJECTOR - EINSPRITZPUMPE UND EINSPRITZDÜSE**

CATALOGO RICAMBI SPARE PARTS		
TAVOLA TABLE	4	1
DATA DATE	5 / 89	

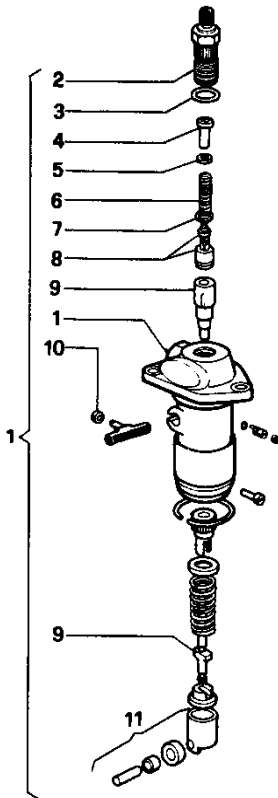

RDM901-RM121  
fino al/untill  
6/1986

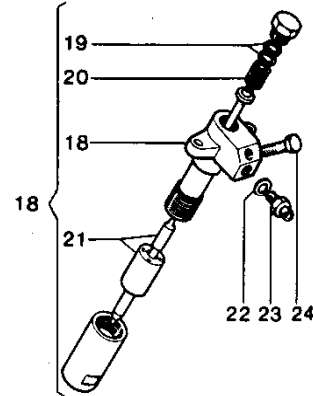

A

RM 80-81-90-91  
RDM901-RM121

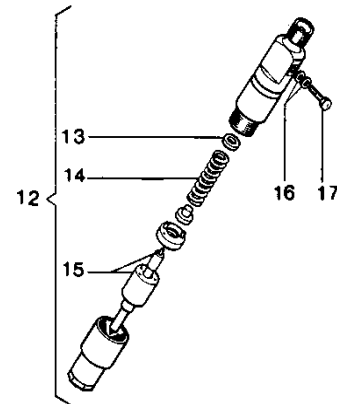

C

Nr. No.	CODICE CODE	DENOMINAZIONE - DENOMINATION - DESCRIPTION - BENENNUNG				Q.
1	656 - 41	Pompa iniez. Omap RM 80-90	Pompe injection	Injection pompe	Einspritzpumpe	1
2	656 - 18	Pompa iniez. Bosch RDM901-RM121	Pompe injection	Injection pompe	Einspritzpumpe	1
	717 - 05	Raccordo RM 80-81	Raccord	Union	Anschlussstück	1
3	579 - 21	Anello O.R.	Bague	Ring	Ring	1
4	717 - 06	Riempitore	Remplisseur	Filler	Fülleinrichtung	1
5	837 - 27	Rondella	Rondelle	Washer	Unterlegscheibe	1
6	540 - 78	Molla	Ressort	Spring	Feder	1
7	754 - 17	Rondella	Rondelle	Washer	Unterlegscheibe	1
8	956 - 31	Valvola Omap RM 80-81-90	Soupape	Valve	Druckventil	1
	956 - 25	Valvola Bosch RDM901 - RM121	Soupape	Valve	Druckventil	1
9	660 - 20	Pompante Omap RM 80-81-90	Elément pompe	Injection plunger	Pumpelement	1
	660 - 13	Pompante Bosch RDM901-RM121	Elément pompe	Injection plunger	Pumpelement	1
10	120 - 28	Bussola	Douille	Sleeve	Büchse	1
11	708 - 08	Punteria	Poussoir	Tappet	Stößel	1
12	644 - 51	Iniettore Omap	Injecteur compl.	Injector	Einspritzdüse	1
13	837 - 30	Rondella	Rondelle	Washer	Unterlegscheibe	1
14	540 - 79	Molla	Ressort	Spring	Feder	1
15	644 - 52	Polverizz. Omap	Injecteur	Nozzle	Düse	1
16	754 - 39	Rondella	Rondelle	Washer	Unterlegscheibe	2
17	717 - 28	Raccordo	Raccord	Union	Anschlussstück	1
18	2499	Iniett. Bosch	Injecteur compl.	Injector	Einspritzdüse	1
19	771 - 32	Rondella	Rondelle	Washer	Unterlegscheibe	2
20	540 - 40	Molla	Ressort	Spring	Feder	1
21	644 - 13	Polverizz. Bosch	Injecteur	Nozzle	Düse	1
22	754 - 24	Rondella	Rondelle	Washer	Unterlegscheibe	1
23	716 - 08	Raccordo	Raccord	Union	Anschlussstück	1
24	716 - 06	Raccordo	Raccord	Union	Anschlussstück	1





**TESTA CILINDRO - CULASSE CYLINDRE**  
**CYLINDER HEAD - CYLINDER - ZYLINDERKOPF ZYLINDER**

Attuale esecuzione  
 Updated execution

CATALOGO RICAMBI SPARE PARTS		
TAVOLA TABLE	5	1
DATA DATE	5 / 89	

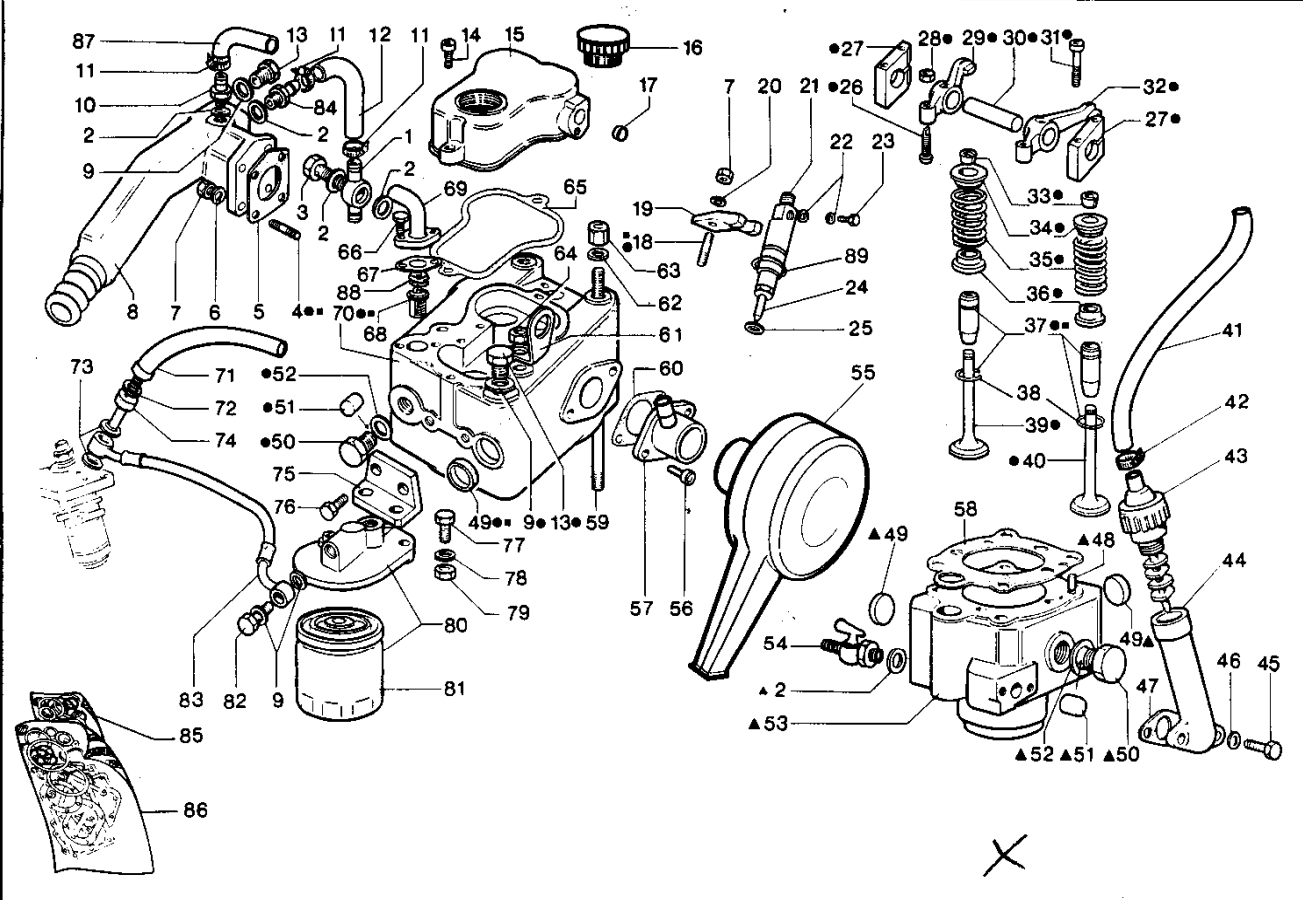

Nr. No.	CODICE CODE	DENOMINAZIONE - DENOMINATION - DESCRIPTION - BENENNUNG				Q.
1	575 - 26	Occhio	Oeillet	Eye	Öse	1
2	754 - 38	Rondella	Rondelle	Washer	Unterlegscheibe	4
3	716 - 76	Raccordo	Raccord	Union	Anschlussstück	1
4	676 - 26	Prigioniero	Goujon	Stud	Stiftschraube	4
5	450 - 36	Guarnizione	Joint	Gasket	Dichtung	1
6	763 - 02	Rondella	Rondelle	Washer	Unterlegscheibe	4
7	325 - 95	Dado	Ecrou	Nut	Mutter	5
8	215 - 30	Collettore sc. - 33513	Collecteur échapp.	Exhaust manifold	Auspuffsammelrohr	1
9	754 - 01	Rondella	Rondelle	Washer	Unterlegscheibe	4
10	717 - 61	Raccordo	Raccord	Union	Anschlussstück	1
11	375 - 58	Fascetta	Collier	Clamp	Rohrschelle	4
12	931 - 09	Tubo RM 80-81-90	Tuyau	Pipe	Rohr	2
	930 - 98	Tubo RDM901-RM121	Tuyau	Pipe	Rohr	1
13	894 - 25	Tappo	Bouchon	Plug	Verschluss	2
14	992 - 07	Vite	Vis	Screw	Schraube	2
15	233 - 38	Coperchio bilancieri	Couvercle	Cover	Deckel	1
16	894 - 33	Tappo carico olio	Bouchon	Plug	Verschluss	1
17	886 - 07	Tappo	Bouchon	Plug	Verschluss	1
18	676 - 03	Prigioniero	Goujon	Stud	Stiftschraube	1
19	858 - 94	Staffa	Etrier	Brace	Bügel	1
20	771 - 97	Rondella	Rondelle	Washer	Unterlegscheibe	1
21	644 - 51	Iniettore Omap	Injecteur comp.	Injector	Einspritzdüse	1
22	754 - 39	Rondella	Rondelle	Washer	Unterlegscheibe	2
23	717 - 28	Raccordo	Raccord	Union	Anschlussstück	1
24	644 - 52	Polverizz. Omap	Injecteur	Nozzle	Düse	1
25	754 - 35	Rondella	Rondelle	Washer	Unterlegscheibe	1
26	726 - 03	Vite registro	Vis réglage	Adjusting screw	Einstellschraube	2
27	910 - 06	Tassello	Taquet	Cushion	Anschlag	2
28	323 - 07	Dado	Ecrou	Nut	Mutter	2
29	104 - 33	Bilanciere scarico	Culbuteur échapp.	Exhaust roker arm	Auslasskippebel	1
30	600 - 87	Perno	Axe	Shaft	Zapfen	1
31	992 - 10	Vite	Vis	Screw	Schraube	4
32	104 - 32	Bilanciere aspirazione	Culbuteur admiss.	Inlet roker arm	Einlasskippebel	1
33	809 - 04	Semicono	Demi-cône	Lock ring	Kegelstück	4
34	616 - 36	Piattello	Coupelle	Cotter	Federteller	2
35	540 - 77	Molla	Ressort	Spring	Feder	2
36	616 - 35	Piattello	Coupelle	Cotter	Federteller	2
37	464 - 56	Guida valvola	Guide	Guide	Führung	2
	464 - 59	Guida valv. +0,1 mm.	Guide	Guide	Führung	2
38	059 - 68	Anello guida	Jonc	Guide ring	Ring	2
39	960 - 50	Valvola scarico RM 80-81-90	Soupape échapp.	Exhauste valve	Auslassventil	1



TESTA CILINDRO - CULASSE CYLINDRE  
CYLINDER HEAD - CYLINDER - ZYLINDERKOPF ZYLINDER

Attuale esecuzione  
Updated execution

CATALOGO RICAMBI SPARE PARTS	
TAVOLA TABLE	5 . 2
DATA DATE	5 / 89

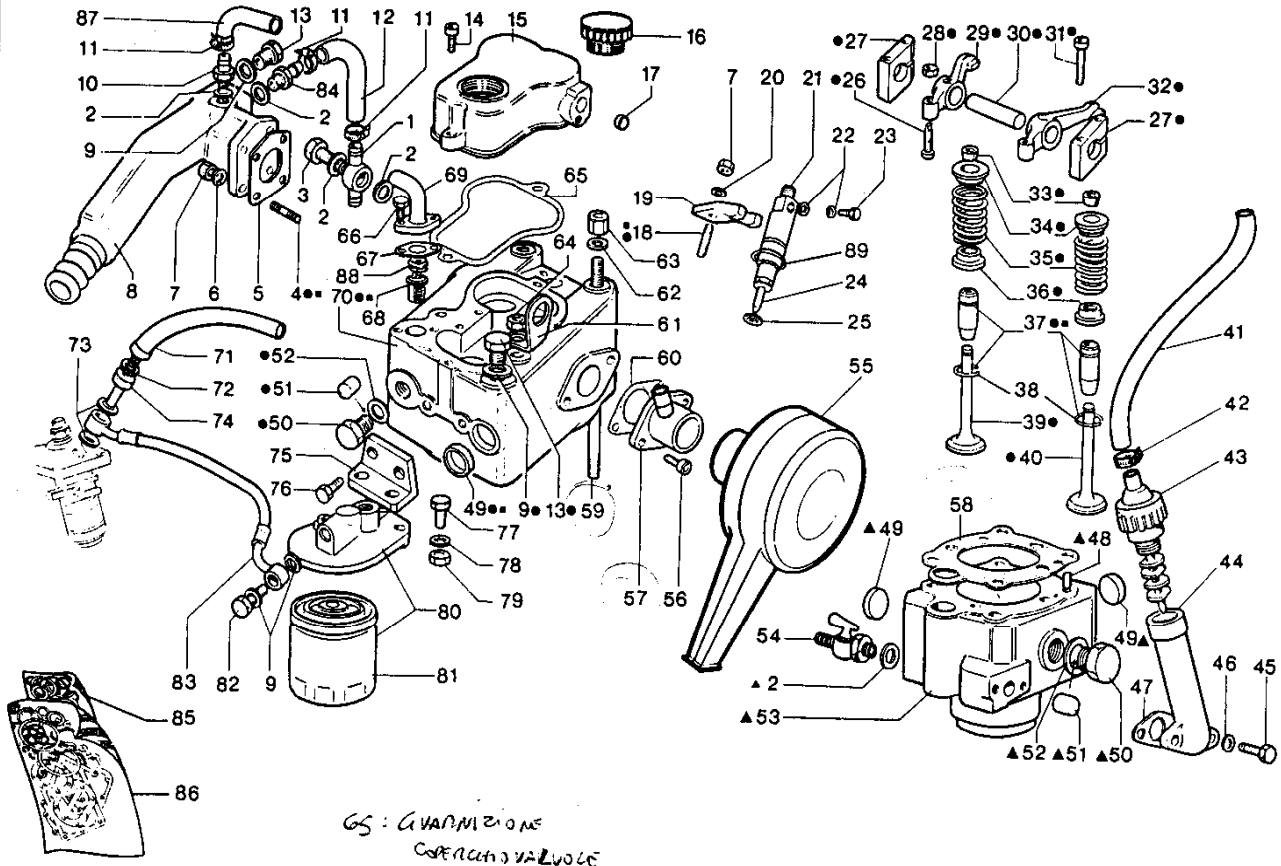

Nr. No.	CODICE CODE	DENOMINAZIONE - DENOMINATION - DESCRIPTION - BENENNUNG				Q.
39	960 - 55	Valv. scarico RDM901-RM121	Soupape échapp.	Exhaust valve	Auslassventil	1
40	960 - 56	Valv. aspiraz RDM901-RM121	Soupape admiss.	Inlet valve	Einlassventil	1
	960 - 49	Valv. aspiraz. RM 80-81-90	Soupape admiss.	Inlet valve	Einlassventil	1
41	948 - 91	Tubo	Tuyau	Pipe	Rohr	1
42	375 - 56	Fascetta	Collier	Clamp	Rohrschelle	2
43	902 - 24	Tappo sfiato	Bouchon	Plug	Verschluss	1
44	219 - 03	Colonneta sfiato	Colonnette	Hollow stud	Stehbolzen	1
45	993 - 10	Vite	Vis	Screw	Schraube	2
46	771 - 06	Rondella	Rondelle	Washer	Unterlegscheibe	2
47	447 - 32	Guarnizione	Joint	Gasket	Dichtung	1
48	841 - 10	Spina cilindrica	Goupille	Pin	Kagelstift	2
49	886 - 42	Tappo	Bouchon	Plug	Verschluss	4
50	894 - 30	Tappo filettato 93162	Bouchon	Plug	Verschluss	2
51	592 - 09	Pastiglia zinco	Pastille	Zinc pad	Zink-verschluss	2
52	754 - 40	Rondella	Rondelle	Washer	Unterlegscheibe	2
53	▲ A2022	Cilindro RM80-81	Cylindre	Cylinder	Zylinder	1
	▲ A2244	Cilindro RM 90-91	Cylindre	Cylinder	Zylinder	1
54	▲ A2152	Cilindro RDM901-RM121	Cylindre	Cylinder	Zylinder	1
55	789 - 18	Rubinetto	Robinet	Shut off valve	Hann	1
56	388 - 07	Filtro aria	Filtre air	Air filter	Luftfilter	1
57	992 - 09	Vite RM 80-81-90	Vis	Screw	Schraube	2
58	510 - 43	Manicotto RM 80-81-90	Manchon	Sheat	Hülle	1
	510 - 46	Manicotto RDM901-RM121	Manchon	Sheat	Hülle	1
59	450 - 31	Guarnizione RM80-81	Joint	Gasket	Dichtung	1
	450 - 98	Guarnizione RDM901-RM 90	Joint	Gasket	Dichtung	1
	684 - 20	Prigioniero RM 80-81-90	Goujon	Stud	Stiftschraube	4
60	684 - 30	Prigioniero RDM901-RM121	Joint	Stud	Stiftschraube	4
	450 - 35	Guarnizione RM 80-81-90	Joint	Gasket	Dichtung	1
61	448 - 14	Guarnizione RDM901-RM121	Joint	Gasket	Dichtung	1
62	427 - 12	Gancio	Crochet	Hook	Haken	1
63	71 - 14	Rondella	Rondelle	Washer	Unterlegscheibe	3
64	325 - 63	Dado alto	Ecrou	Nut	Mutter	3
65	323 - 32	Dado	Ecrou	Nut	Mutter	1
66	449 - 10	Guarnizione	Joint	Gasket	Dichtung	1
67	993 - 06	Vite	Vis	Screw	Schraube	2
68	449 - 53	Guarnizione	Joint	Gasket	Dichtung	1
69	956 - 26	Valvola termostatica	Valve thermostatique	Thermostatic valve	Thermostatisches ventil	1
70	930 - 76	Tubo	Tuyau	Pipe	Rohr	1
	▲ A2023	Testa con guide RM 80-81-90	Culasse avec guide	Cyl. head with guides	Zylinderkopf mit führung	1
	▲ A2024	Testa completa RM 80-81-90	Culasse complète	Complete gaskets	Zylinderkopf komplette	1
	A2161	Testa con guide RDM901-121	Culasse avec guide	Cyl. head with guides	Zylinderkopf mit führung	1



**TESTA CILINDRO - CULASSE CYLINDRE**  
**CYLINDER HEAD - CYLINDER - ZYLINDERKOPF ZYLINDER**

Attuale esecuzione  
Updated execution

CATALOGO RICAMBI SPARE PARTS		
TAVOLA TABLE	5	3
DATA DATE	5 / 89	

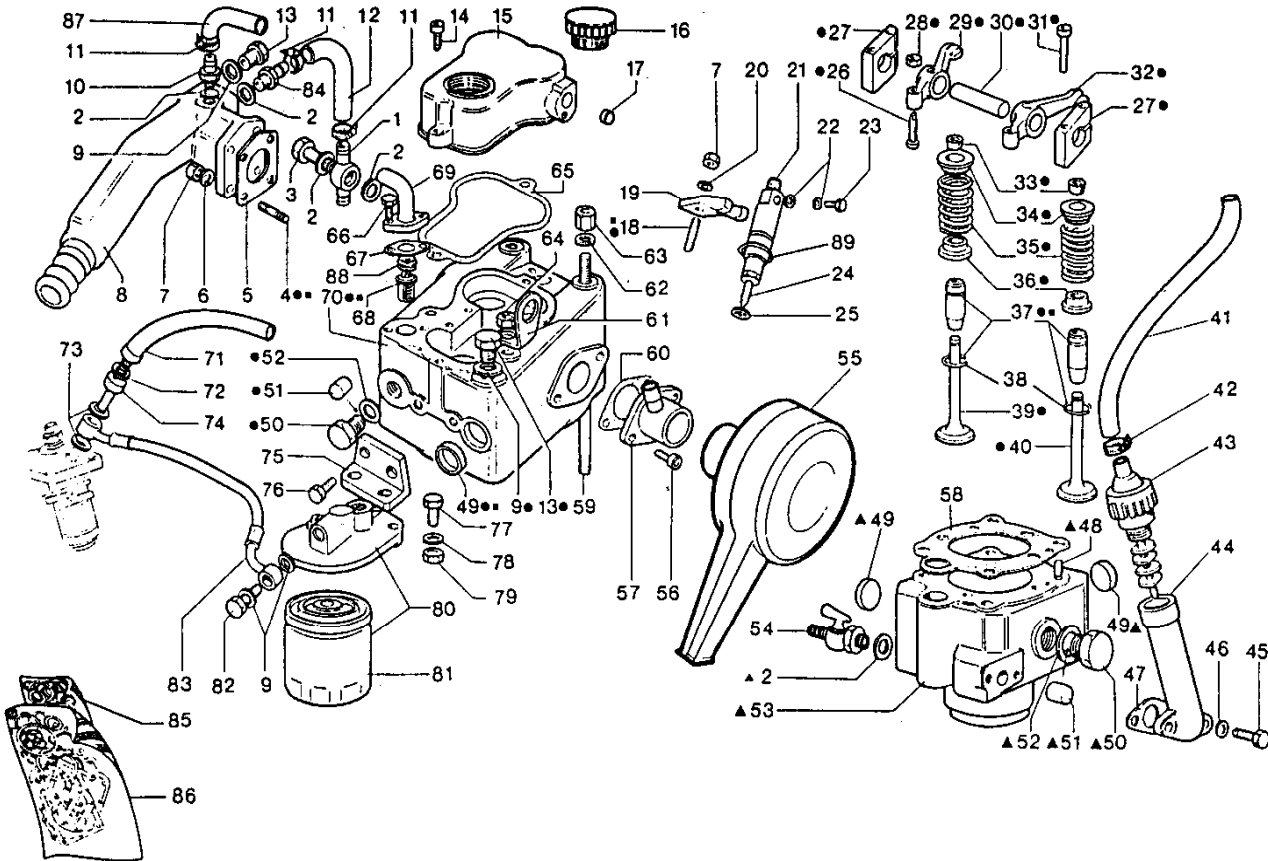

Nr. No.	CODICE CODE	DENOMINAZIONE - DENOMINATION - DESCRIPTION - BENENNUNG				Q.
71	A2162	Testa completa RDM901-121	Culasse compl.	Cyl. head compl.	Zylinderkopf komplette	1
	936 - 80	Tubo RM80-81	Tuyau	Pipe	Rohr	1
	936 - 72	Tubo RDM901-RM121	Tuyau	Pipe	Rohr	1
72	754 - 02	Rondella	Rondelle	Washer	Unterlegscheibe	1
73	754 - 07	Rondella	Rondelle	Washer	Unterlegscheibe	2
74	717 - 17	Raccordo disaerazione	Raccord	Union	Anschlussstück	1
75	613 - 06	Supporto	Support	Support	Lager	1
76	993 - 16	Vite	Vis	Screw	Schraube	2
77	993 - 01	Vite	Vis	Screw	Schraube	2
78	771 - 09	Rondella	Rondelle	Washer	Unterlegscheibe	2
79	323 - 03	Dado	Ecrou	Nut	Mutter	2
80	391 - 21	Filtro gasolio RM80-81	Filtre carbur.	Fuel filter	Brennstofffilter	1
	391 - 15	Filtro gasolio RDM901-RM121	Filtre carbur.	Fuel filter	Brennstofffilter	1
81	175 - 23	Cartuccia RM80-81 <i>meja</i>	Cartouche	Cartridge	Patrone	1
	175 - 20	Cartuccia RDM901-RM121	Cartouche	Cartridge	Patrone	1
82	716 - 15	Raccordo	Raccord	Union	Anschlussstück	1
83	935 - 50	Tubo RM80-81	Tuyau	Pipe	Rohr	1
	935 - 55	Tubo RDM901-RM121	Tuyau	Pipe	Rohr	1
84	716 - 97	Raccordo	Raccord	Union	Anschlussstück	1
85	A2026	Guarniz. smerig. RM80-81	Joint	Overhauling gasket	Dichtung	1
85	A2165	Guarniz. Smerig. RDM901-RM90	Joint	Overhauling gasket	Dichtung	1
86	A2027	Guarniz. compl. RM80-81	Joint	Complete gasket	Dichtung	1
86	A2166	Guarniz. compl. RDM901-RM90	Joint	Complete gasket	Dichtung	1
87	930 - 78	Tubo	Tuyau	Pipe	Rohr	1
88	540 - 81	Molla	Ressort	Spring	Feder	1
89	579 - 71	Anello OR	Bague	Ring	Ring	1

58: HEAD GASKET



TESTA CILINDRO - CULASSE CYLINDRE RDM 901  
CYLINDER HEAD - CYLINDER - ZYLINDERKOPF ZYLINDER RM 121

CATALOGO RICAMBI SPARE PARTS		
TAVOLA TABLE	5	4
DATA DATE	5 / 89	

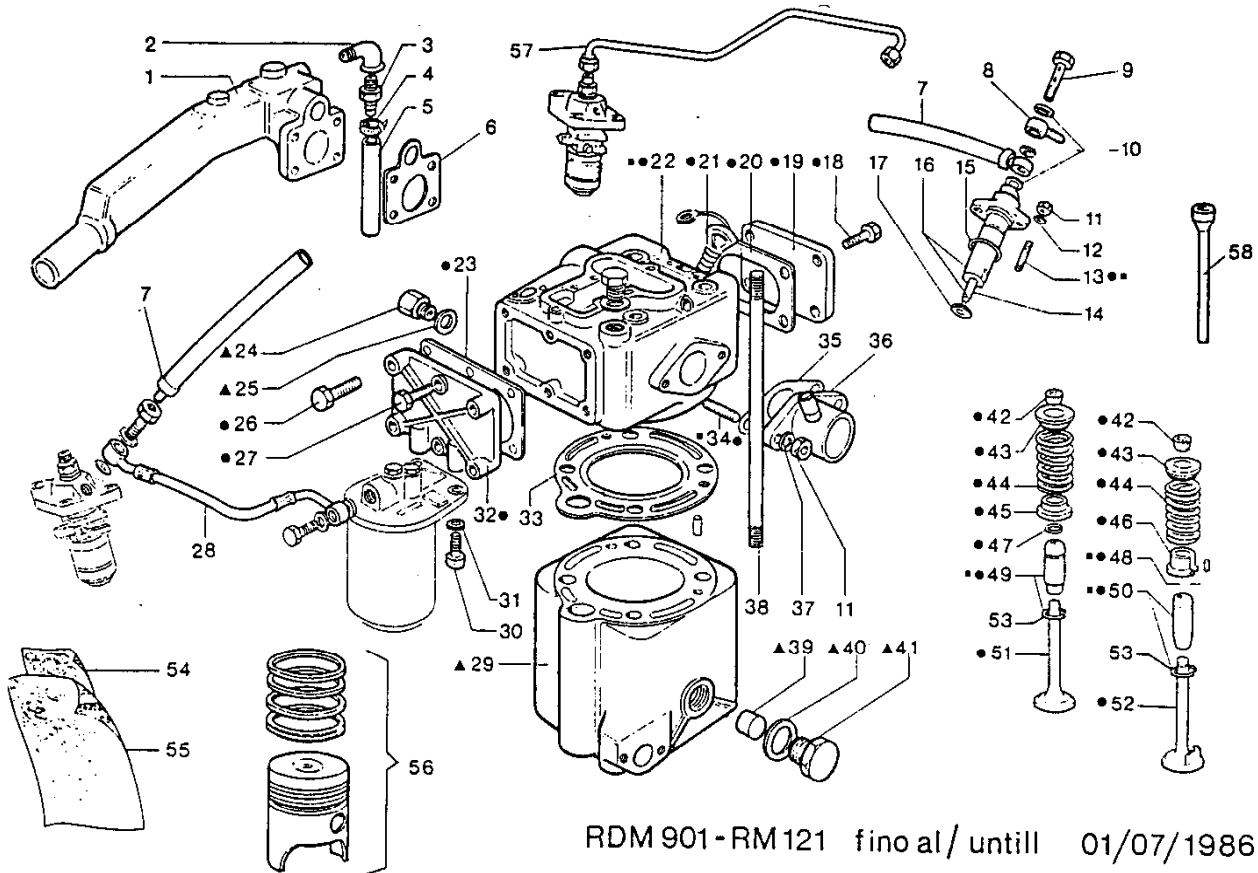

RDM 901-RM121 fino al/untill 01/07/1986

Nr. No.	CODICE CODE	DENOMINAZIONE - DENOMINATION - DESCRIPTION - BENENNUNG				Q.
1	215 - 38	Collettore scarico	Collecteur échapp.	Exhaust manifold	Auspuffsammelrohr	1
2	716 - 63	Raccordo	Raccord	Union	Anschlussstück	1
3	716 - 97	Raccordo	Raccord	Union	Anschlussstück	2
4	375 - 35	Fascetta	Collier	Clamp	Rohrschelle	2
5	930 - 60	Tubo	Tuyau	Pipe	Rohr	1
6	448 - 61	Guarnizione	Joint	Gasket	Dichtung	1
7	936 - 19	Tubo sfiato	Tuyau	Pipe	Rohr	1
8	575 - 04	Occhio	Oeillet	Eye	Öse	1
9	716 - 17	Raccordo	Raccord	Union	Anschlussstück	1
10	754 - 02	Rondella	Rondelle	Washer	Unterlegscheibe	3
11	325 - 95	Dado	Ecrou	Nut	Mutter	4
12	750 - 06	Rondella dentellata	Rondelle	Washer	Unterlegscheibe	2
13	676 - 16	Prigioniero	Goujon	Stud	Stiftschraube	2
14	644 - 13	Polverizzatore Bosch	Injecteur	Nozzle	Düse	1
15	579 - 51	Anello OR	Bague	Ring	Ring	1
16	2499	Iniettore Bosch	Injecteur compl.	Injector	Einspritzdüse	1
17	754 - 06	Rondella	Rondelle	Washer	Unterlegscheibe	1
18	993 - 01	Vite	Vis	Screw	Schraube	4
19	231 - 86	Coperchio	Couvercle	Cover	Deckel	1
20	448 - 63	Guarnizione	Joint	Gasket	Dichtung	1
21	2248	Tappo cicchetto	Bouchon	Plug	Verschluss	1
22	■ 2424	Testa con guide	Culasse avec guide	Cyl. head with guides	Zylinderkopf mit Führung	1
	● 2423	Testa completa	Culasse complète	Cyl. head complete	Zylinderkopf komplette	1
23	449 - 26	Guarnizione	Joint	Gasket	Dichtung	1
24	716 - 96	Raccordo	Raccord	Union	Anschlussstück	1
25	754 - 38	Rondella	Rondelle	Washer	Unterlegscheibe	1
26	993 - 23	Vite	Vis	Screw	Schraube	4
27	993 - 16	Vite	Vis	Screw	Schraube	2
28	935 - 55	Tubo	Tuyau	Pipe	Rohr	1
29	▲ 2422	Cilindro	Cylindre	Cylinder	Zylinder	1
30	992 - 12	Vite	Vis	Screw	Schraube	2
31	771 - 09	Rondella	Rondelle	Washer	Unterlegscheibe	2
32	232 - 21	Coperchio	Couvercle	Cover	Deckel	1
33	448 - 58	Guarnizione	Joint	Gasket	Dichtung	1
34	676 - 02	Prigioniero	Goujon	Stud	Stiftschraube	2
35	448 - 14	Guarnizione	Joint	Gasket	Dichtung	1
36	510 - 46	Manicotto	Manchon	Sheat	Hülle	1
37	763 - 02	Rondella	Rondelle	Washer	Unterlegscheibe	2
38	684 - 09	Prigioniero	Goujon	Stud	Stiftschraube	4
39	592 - 09	Pastiglia zinco	Pastille	Zinc-pad	Zink-Verschluss	1



TESTA CILINDRO - CULASSE CYLINDRE  
CYLINDER HEAD - CYLINDER - ZYLINDERKOPF ZYLINDER

RDM 901  
RM 121

CATALOGO RICAMBI  
SPARE PARTS

TAVOLA  
TABLE 5 5

DATA  
DATE 5 / 89

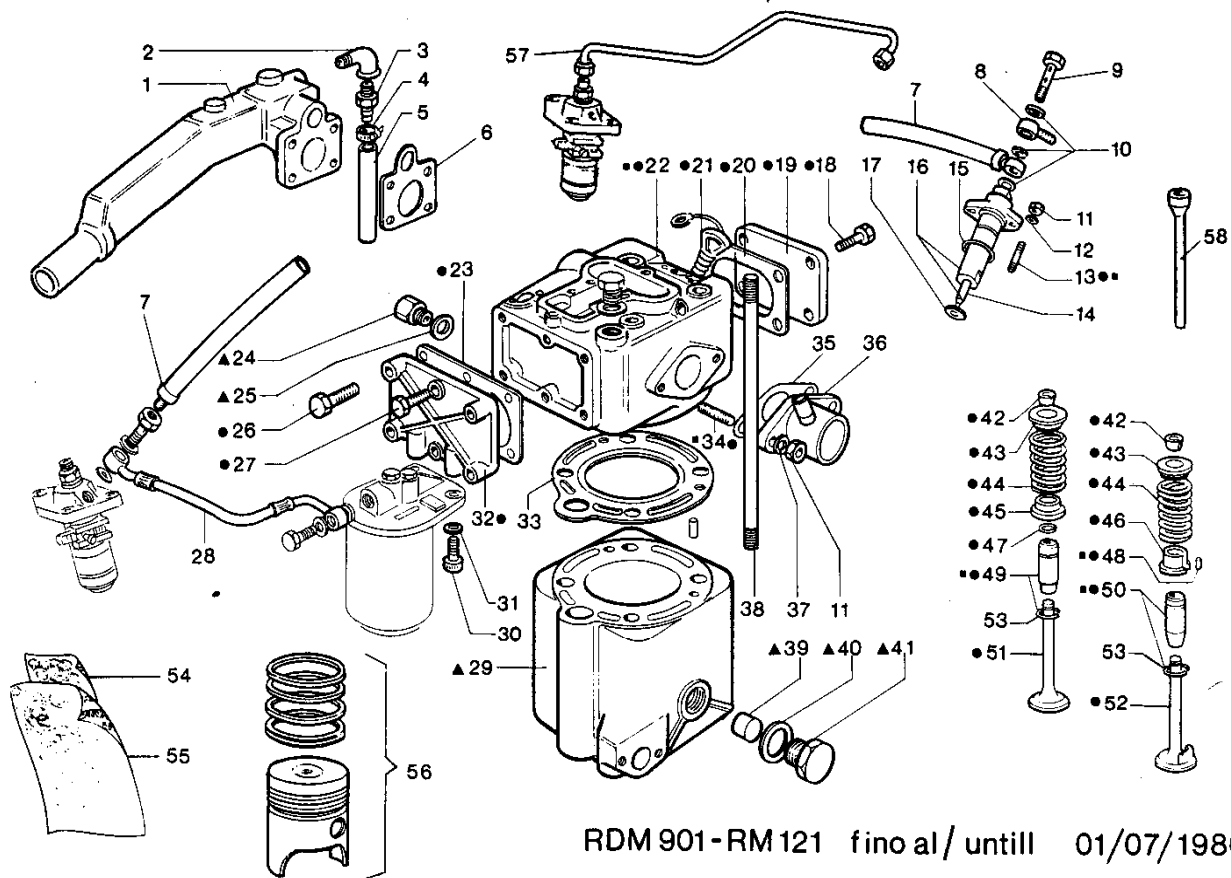

RDM 901-RM 121 fino al/untill 01/07/1986

Nr. No.	CODICE CODE	DENOMINAZIONE - DENOMINATION - DESCRIPTION - BENENNUNG				Q.
40	754 - 40	Rondella	Rondelle	Washer	Unterlegscheibe	1
41	894 - 30	Tappo	Bouchon	Plug	Verschluss	1
42	809 - 01	Semicono	Demi-cône	Lock-ring	Kegelstück	4
43	616 - 12	Piattello sup.	Coupelle	Cotter	Federteller	2
44	540 - 26	Molla	Ressort	Spring	Feder	2
45	616 - 11	Piattello inf. sc.	Coupelle	Cotter	Federteller	1
46	616 - 13	Piattello inf. asp.	Coupelle	Cotter	Federteller	1
47	059 - 02	Anello valvola sc.	Jonc échapp.	Exhaust ring	Ring	1
48	850 - 05	Spina	Goupille	Pin	Kegelstift	1
49	464 - 40	Guida valvola sc.	Guide échapp.	Exhaust guide	Auslassventilführung	1
	464 - 35	Guida valvola +0,1 mm.	Guide échapp.	Exhaust guide	Auslassventilführung	1
50	464 - 39	Guida valvola asp.	Guide admission	Inlet guide	Einlassventilführung	1
	464 - 25	Guida valvola +0,1 mm.	Guide admission	Inlet guide	Einlassventilführung	1
51	960 - 46	Valvola scarico	Soupape échapp.	Exhaust valve	Auslassventil	1
52	960 - 45	Valvola aspirazione	Soupape admission	Inlet valve	Einlassventil	1
53	059 - 01	Anello guida valvola	Jonc	Guide ring	Ring	2
54	2420	Guarniz. smeriglio	Joint	Overhauling gasket	Dichtung	1
55	2419	Guarniz. completa	Joint	Complete gasket	Dichtung	1
56	2144	Pist. Ø 90 mm.	Piston	Piston	Kolben	1
	2145	Pist. Ø 90,5 mm.	Piston	Piston	Kolben	1
	2146	Pist. Ø 91 mm.	Piston	Piston	Kolben	1
	2147	Pist. Ø 91,5 mm.	Piston	Piston	Kolben	1
57	944 - 14	Tubo iniez.	Tube injection	Injection pipe	Rohr	1
58	071 - 71	Aste bilancieri	Tige poussoir	Push rod	Stoßstange	2



VARIANTI PER RDM901 CON ELETTROVALVOLA - VARIATION POUR RDM901 AVEC ELECTROVANNE  
 VARIATIONS FOR RDM901 WITH SOLENOID - VERÄNDERUNG FÜR RDM901 MIT ELEKTROVENTIL

CATALOGO RICAMBI  
 SPARE PARTS

TAVOLA 5 6  
 TABLE

DATA 5 / 89  
 DATE

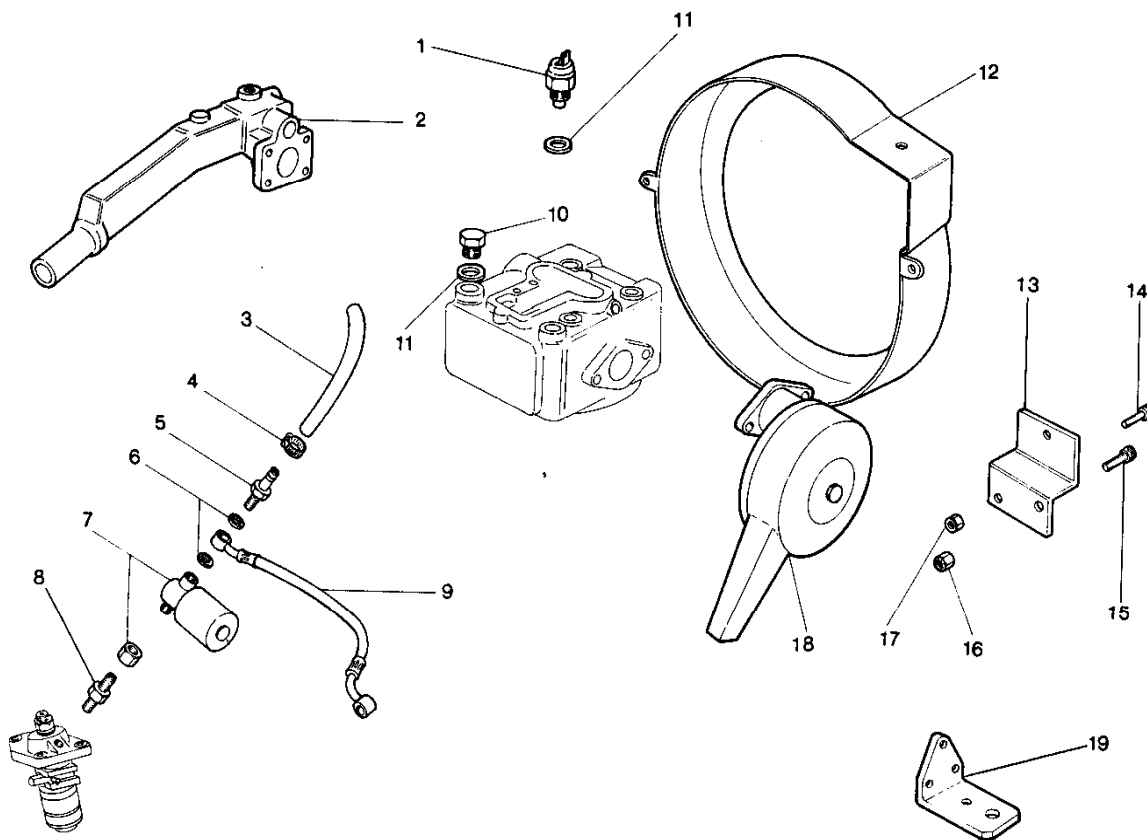

Nr. No.	CODICE CODE	DENOMINAZIONE - DENOMINATION - DESCRIPTION - BENENNUNG				Q.
1	674 - 14	Bulbo per termometro	Boule thermomètre	Thermometer bulb	Thermometer Kugel	1
2	215 - 27	Collettore scarico	Collecteur échapp.	Exhaust manifold	Auspuffsammelrohr	1
3	935 - 82	Tubo	Tuyau	Pipe	Rohr	1
4	375 - 08	Fascetta	Collier	Clamp	Rohrschelle	1
5	717 - 19	Raccordo disaerazione	Raccord	Union	Anschlussstück	1
6	754 - 02	Rondella	Rondelle	Washer	Unterlegscheibe	4
7	674 - 29	Elettrovalvola	Electrovanne	Solenoid valve	Elektroventil	1
8	717 - 20	Raccordo	Raccord	Union	Anschlussstück	1
9	936 - 62	Tubo	Tuyau	Pipe	Rohr	1
10	894 - 25	Tappo filettato	Bouchon	Plug	Verschluss	1
11	754 - 01	Rondella	Rondelle	Washer	Unterlegscheibe	2
12	171 - 16	Protezione volano	Protection	Guard	Schutz	1
13	877 - 40	Supporto est. alternatore	Support	Support	Lager	1
14	989 - 50	Vite	Vis	Screw	Schraube	1
15	992 - 50	Vite	Vis	Screw	Schraube	1
16	323 - 43	Dado autoblocc.	Ecrou	Nut	Mutter	1
17	323 - 49	Dado autoblocc.	Ecrou	Nut	Mutter	1
18	387 - 83	Filtro aria	Filtre air	Air filter	Luftfilter	1
19	625 - 84	Piede motore	Pied	Mount	Fuss	2

VECCATO