

# **THERMAL**

Generatore d'acqua calda (\*)

Chauffe-eau (\*)

Warmwasserheizung (\*)

Hot water heater (\*)

Calentador de agua (\*)



L-DC025.00-BM

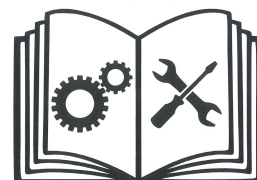

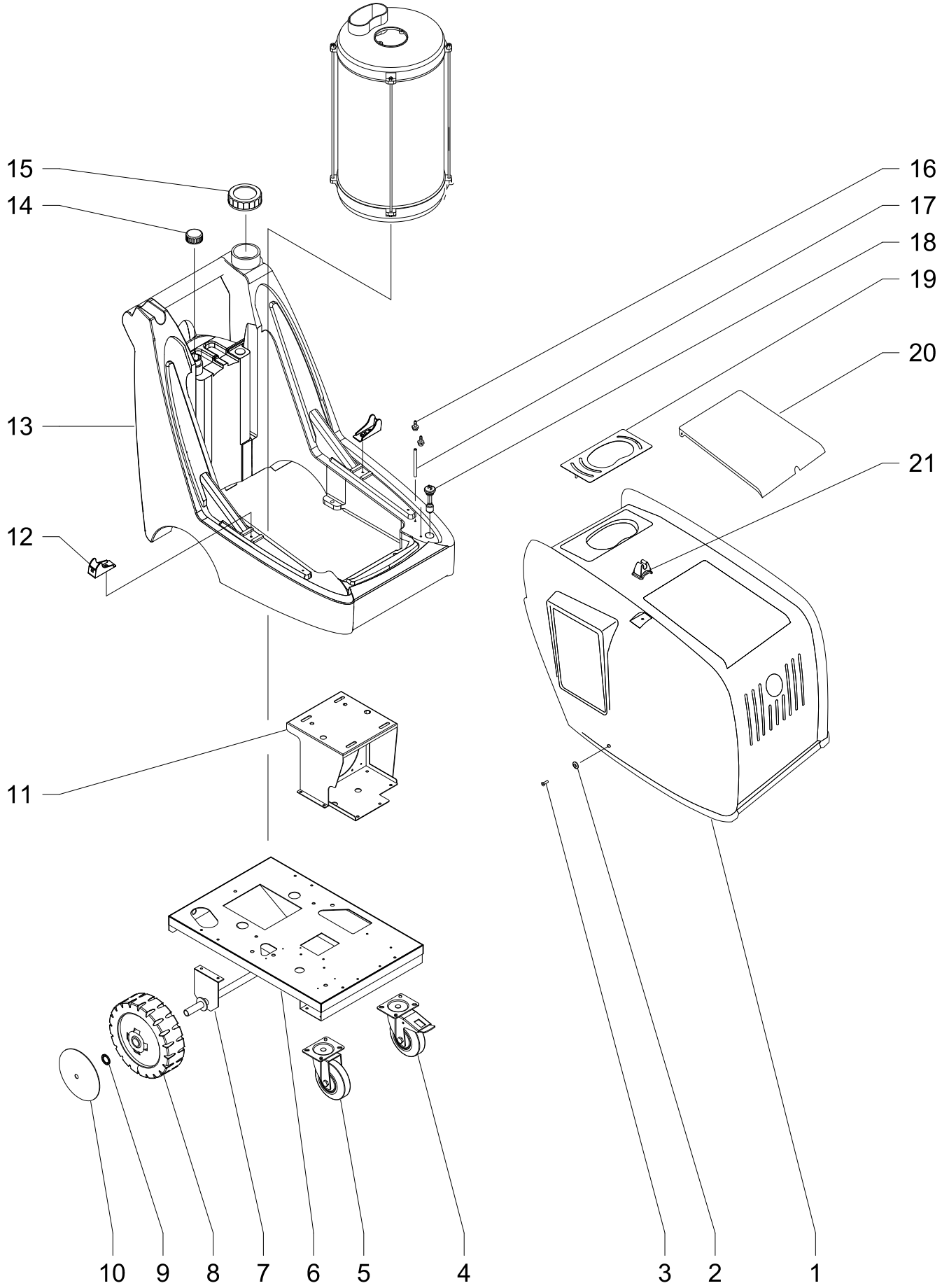

TABLE N° EXPL00146

## SPARE PARTS LIST

GR. LAM. THERMAL

11/07/2016

REF	CODE	QTY	DESCRIPTION	DENOMINATION	BESCHREIBUNG	DESCRIPCION	DESCRIZIONE	TECNICAL FEATURES		
01	B. PLDS00337	01	HOOD	CAPOT	HAUBE	COFRE	COFANO	THERMAL T40		
01	B. PLDS00315	01	HOOD	CAPOT	HAUBE	COFRE	COFANO	THERMAL T30		
02	B. VTRD00001	02	WASHER	RONDELLE	DICHTUNG	ARANDELLA	RONDELLA			
03	B. VTVT00300	02	SCREW	VIS	SCHRAUBE	TORNILLO	VITE			
04	C10538	01	WHEEL	ROUE	LAUFRAD	RUEDA	RUOTA			
05	B. RUOT00031	01	WHEEL	ROUE	LAUFRAD	RUEDA	RUOTA			
06	B. CRVR00702	01	FRAME	CHASSIS	GERUST	CHASIS	TELAIO			
07	L01244	01	AXLE	AXE	ACHESE	EJE	ASSE			
08	C10531G	02	WHEEL	ROUE	LAUFRAD	RUEDA	RUOTA			
09	M20203	02	WASHER	RONDELLE	DICHTUNG	ARANDELLA	RONDELLA			
10	C10532	02	WHEEL COVER	COUVRE TOURNE	VERLANGERUNG	EMBELLECEDOR	COPRIRUOTA			
11	B. CRVR00703	01	SUPPORT	SUPPORT	HALTER	SOPORTE	SUPPORTO			
12	B. PLDS00323	02	BRACKET	ENTRIER	BUGEL	GRAPA	STAFFA			
13	P50118	01	TANK	RESERVOIR	TANK	DEPOSITO	SERBATOIO			
14	P50122	02	CAP	BOUCHON	VERSCHLUSS	TAPPO	TAPPO			
15	P50108	01	CAP	BOUCHON	VERSCHLUSS	TAPPO	TAPPO			
16	B. RCVR00007	02	HOSE FITTING	RACC. P. TUYAU	SCHLAUCH HALTER	PORTAMANGUERA	PORTAGOMMA			
17	I40306	00	HOSE	TUYAU	ROHR	TUBO	TUBO			
18	B. MEIP00048	01	SWITCH	INTERRUPTEUR	SCHALTER	INTERRUPTOR	INTERRUTTORE			
19	B. CRDS00765	01	REINFORCEMENT	RENFORT	VERSTARKUNG	REFUERZO	RINFORZO			
20	B. PLDS00319	01	COVER	COUVERCLE	DECKEL	TAPA	COPERCHIO	THERMAL T30		
21	B. PLDS00325	01	SUPPORT	SUPPORT	HALTER	SOPORTE	SUPPORTO			

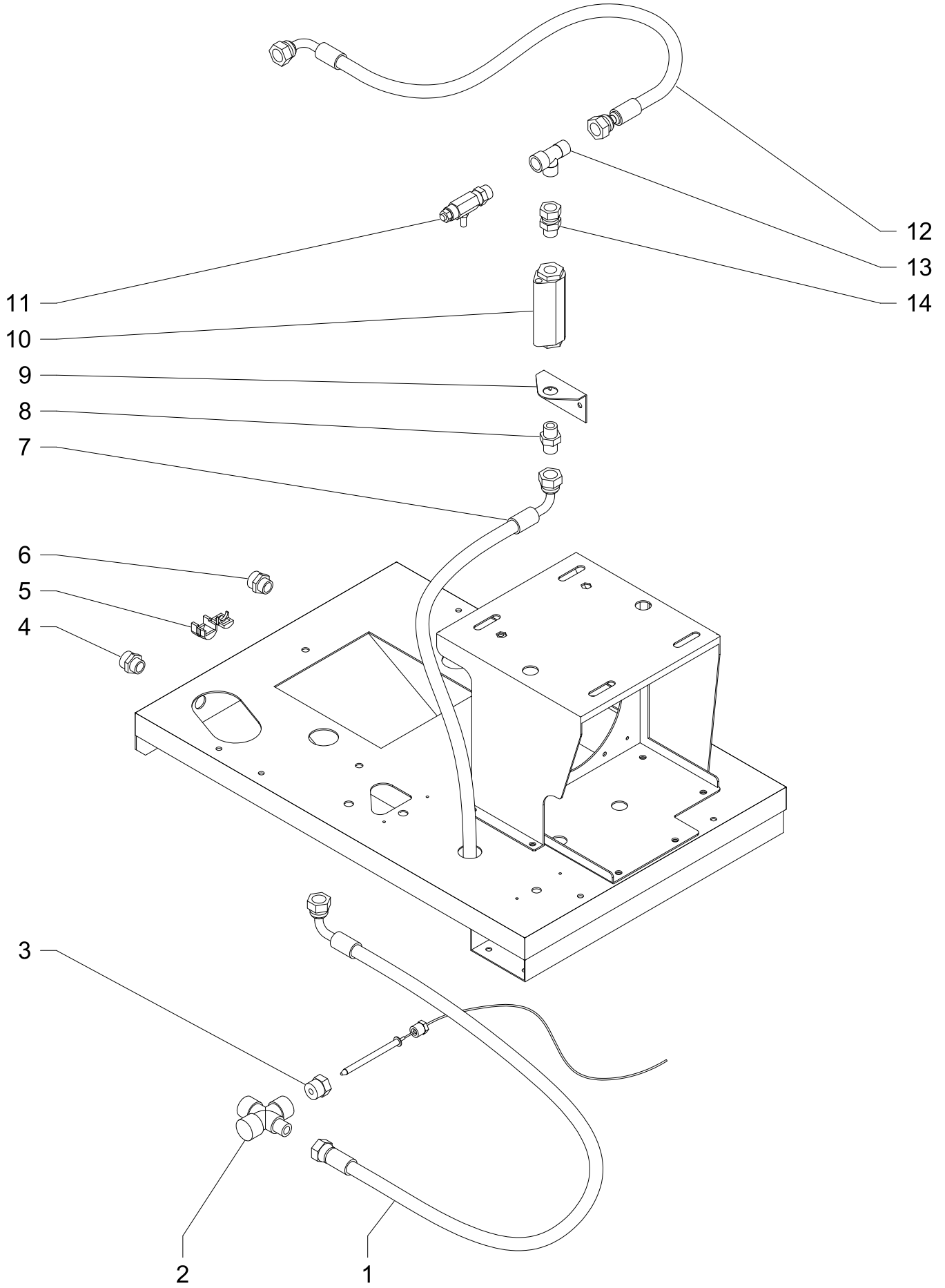

TABLE N° EXPL00147

## SPARE PARTS LIST

GR. RACCORDI THERMAL T30

11/07/2016

REF	CODE	QTY	DESCRIPTION	DENOMINATION	BESCHREIBUNG	DESCRIPCION	DESCRIZIONE	TECNICAL FEATURES		
01	B. TURR00004	01	HOSE	TUYAU	ROHR	TUBO	TUBO			
02	B. RCVR00194	01	CONNECTOR	RACCORD	VERBIND. STUCK	RACORD	RACCORDO			
03	I30307	01	REDUCTION	RÉDUCTION	VERKLEINERUNG	REDUCCIÓN	RIDUZIONE			
04	I20920	01	REDUCTION	RÉDUCTION	VERKLEINERUNG	REDUCCIÓN	RIDUZIONE			
05	B. MEVR00319	01	CABLE CLAMP	COLLIER	KABELSCHELLE	ABRAZADERA CABL	PRESSACAVO			
06	B. RCVR00173	01	REDUCTION	RÉDUCTION	VERKLEINERUNG	REDUCCIÓN	RIDUZIONE			
07	B. TURR00028	01	HOSE	TUYAU	ROHR	TUBO	TUBO			
08	I20102	01	NIPPLE	NIPPLE	NIPPEL	NIPLO	NIPPLO			
09	B. CRZN00668	01	BRACKET	ENTRIER	BUGEL	GRAPA	STAFFA			
10	B. MEFL00000	01	FLOW SWITCH	FLUSSOSTAT	STROMUNGSWACHTE	INT. DE FLUJO	FLUSSOSTATO			
11	B. I10433	01	VALVE	SOUPAPE	VENTIL	VALVULA	VALVOLA			
12	B. TURR00028	01	HOSE	TUYAU	ROHR	TUBO	TUBO			
13	B. RCVR00022	01	CONNECTOR	RACCORD	VERBIND. STUCK	RACORD	RACCORDO			
14	B. I20602	01	CONNECTOR	RACCORD	VERBIND. STUCK	RACORD	RACCORDO			

**EXPLODED VIEW**

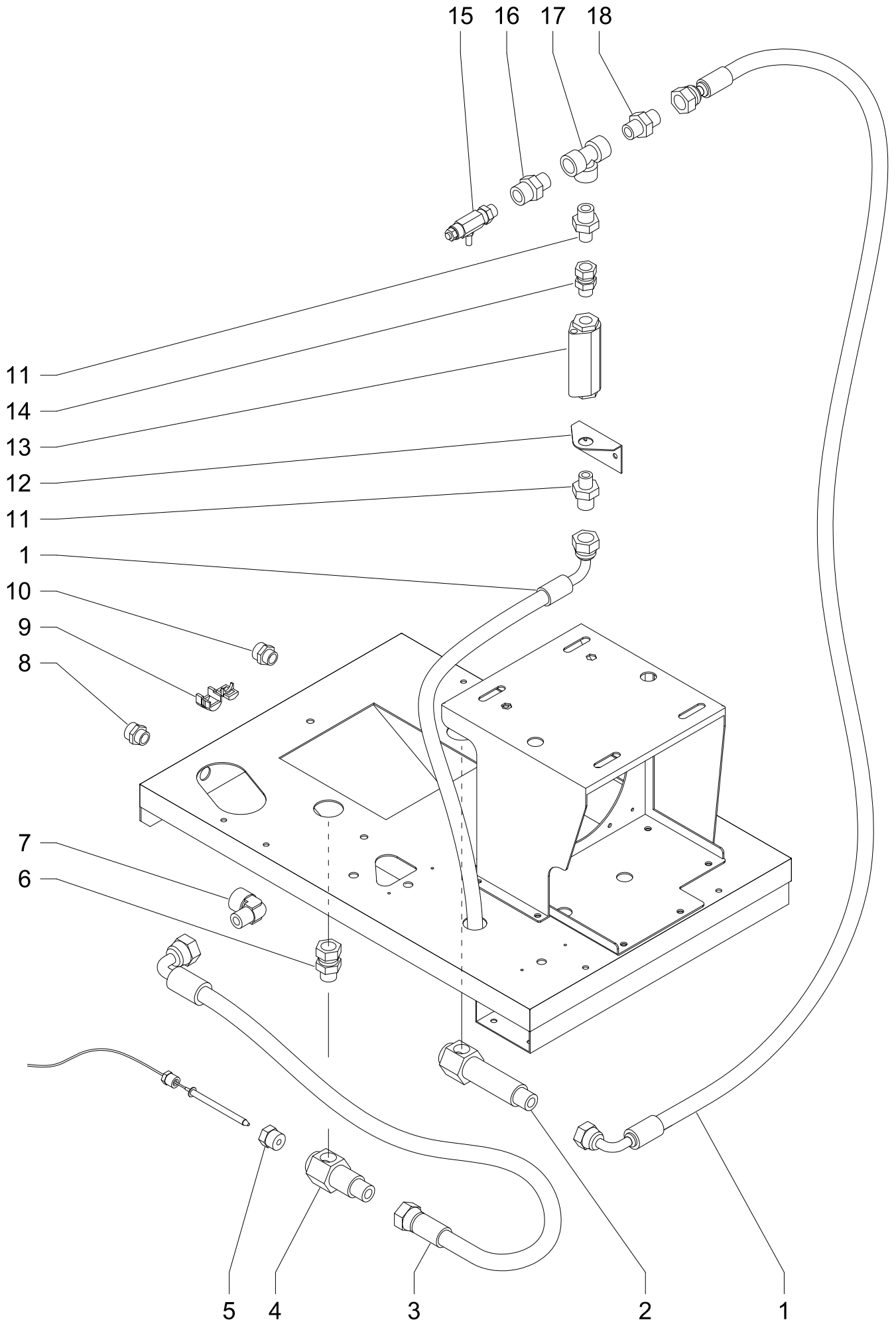

TABLE N° EXPL00148

## SPARE PARTS LIST

GR. RACCORDI THERMAL T40

11/07/2016

REF	CODE	QTY	DESCRIPTION	DENOMINATION	BESCHREIBUNG	DESCRIPCION	DESCRIZIONE	TECNICAL FEATURES		
01	B. TURR00035	02	HOSE	TUYAU	ROHR	TUBO	TUBO			
02	B. RCVR00192	01	CONNECTOR	RACCORD	VERBIND. STUCK	RACORD	RACCORDO			
03	B. TURR00033	01	HOSE	TUYAU	ROHR	TUBO	TUBO			
04	B. RCVR00193	01	CONNECTOR	RACCORD	VERBIND. STUCK	RACORD	RACCORDO			
05	I30307	02	REDUCTION	RÉDUCTION	VERKLEINERUNG	REDUCCIÓN	RIDUZIONE			
06	I20601	01	CONNECTOR	RACCORD	VERBIND. STUCK	RACORD	RACCORDO			
07	I20305	01	CONNECTOR	RACCORD	VERBIND. STUCK	RACORD	RACCORDO			
08	I20920	01	REDUCTION	RÉDUCTION	VERKLEINERUNG	REDUCCIÓN	RIDUZIONE			
09	B. MEVR00319	01	CABLE CLAMP	COLLIER	KABELSCHELLE	ABRAZADERA CABL	PRESSACAVO			
10	B. RCVR00173	01	REDUCTION	RÉDUCTION	VERKLEINERUNG	REDUCCIÓN	RIDUZIONE			
11	I20113	02	NIPPLE	NIPPLE	NIPPEL	NIPLO	NIPPLO			
12	B. CRZN00668	01	BRACKET	ENTRIER	BUGEL	GRAPA	STAFFA			
13	B. MEFL00000	01	FLOW SWITCH	FLUSSOSTAT	STROMUNGSWACHTE	INT. DE FLUJO	FLUSSOSTATO			
14	I20602	01	CONNECTOR	RACCORD	VERBIND. STUCK	RACORD	RACCORDO			
15	I10433	01	VALVE	SOUPAPE	VENTIL	VALVULA	VALVOLA			
16	I20201	01	NIPPLE	NIPPLE	NIPPEL	NIPLO	NIPPLO			
17	B. RCVR00205	01	CONNECTOR	RACCORD	VERBIND. STUCK	RACORD	RACCORDO			
18	B. RCVR00011	01	NIPPLE	NIPPLE	NIPPEL	NIPLO	NIPPLO			

**EXPLODED VIEW**

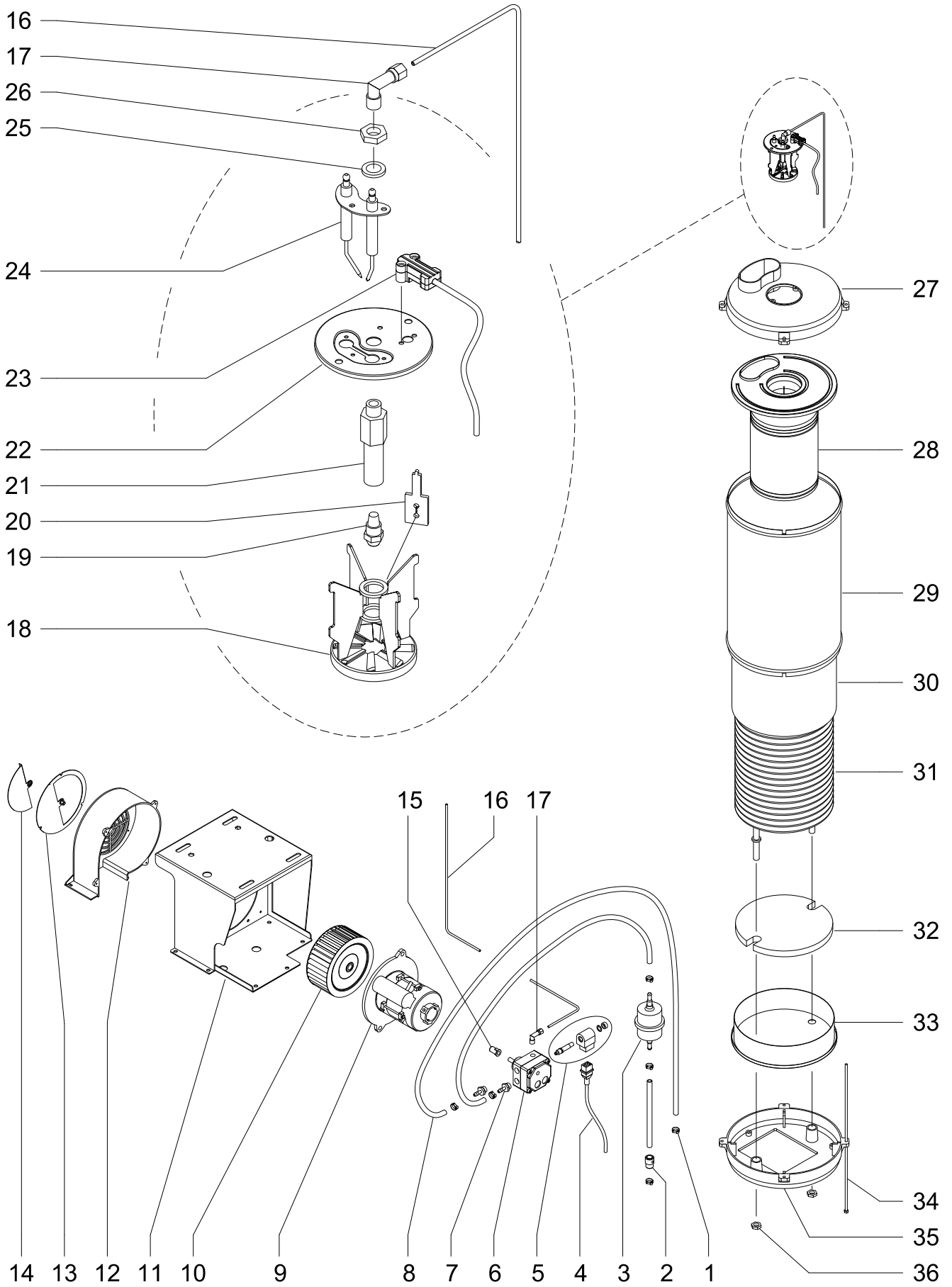



TABLE N° EXPL00149

## SPARE PARTS LIST

GR. BOILER-FAN THERMAL

08/02/2017

REF	CODE	QTY	DESCRIPTION	DENOMINATION	BESCHREIBUNG	DESCRIPCION	DESCRIZIONE	TECNICAL FEATURES
01	B. VTSP00110	06	RING	ANNEAU	RING	ANILLO	FASCETTA	
02	B. RCVR00182	01	TAP	ROBINET	ZAPFHAHN	CANILLA	RUBINETTO	
03	I30414	01	FILTER	FILTRE	FILTER	FILTRO	FILTRO	
04	T20442	01	CABLE	CABLE	KABEL	CABLE	CAVO	
05	B. METR00024	01	COIL	BOBINE	SPULE	BOBINA	BOBINA	
06	T20450	01	PUMP	POMPE	PUMPE	BOMBA	POMPA	
07	B. RCVR00172	02	HOSE FITTING	RACC. P. TUYAU	SCHLAUCH HALTER	PORTAMANGUERA	PORTAGOMMA	
08	B. TUFL01012	01	HOSE	TUYAU	ROHR	TUBO	TUBO	
09	B. MOAC00039	01	MOTOR	MOTEUR	MOTOR	MOTOR	MOTORE	
10	T10255	01	FAN	HELICE	LUFTERRAD	TURBINA	VENTOLA	
11	B. CRVR00713	01	SUPPORT	SUPPORT	HALTER	SOPORTE	SUPPORTO	
12	C10323	01	SPIRAL FAN	ECROU VENTIL.	SCHNECKE VENTIL	ESPIRAL VENTIL.	COCLEA VENTIL.	
13	B. CRZN00665	01	SUPPORT	SUPPORT	HALTER	SOPORTE	SUPPORTO	
14	B. CRZN00666	01	SHUTTER	OBTURATEUR	SCHALTER	VENTANILLA	SERRANDA	
15	E10698	01	FLEX. COUPLING	ACCOUPLMENT FL	FLEX. KOPPELUNG	ACOPLADOR FLEX.	GIUNTO	
16	B. RCVR00180	01	HOSE	TUYAU	ROHR	TUBO	TUBO	
17	I30856	01	CONNECTOR	RACCORD	VERBIND. STUCK	RACORD	RACCORDO	
18	B. CRDS00780	01	TURBULATOR	TURBULATEUR	TURBULATOR	TURBULADOR	TURBOLATORE	
19	T20370	01	NOZZLE	BUSE	DUSE	BOQUILLA	UGELLO	
20	B. CRDS00782	01	BRACKET	ENTRIER	BUGEL	GRAPA	STAFFA	
21	I30688	01	CONNECTOR	RACCORD	VERBIND. STUCK	RACORD	RACCORDO	
22	B. CRDS00778	01	FLANGE	BRIDE	FLANSCH	BRIDA	FLANGIA	
23	B. PMVR00174	01	PHOTORESISTANCE	PHOTORESISTANCE	PHOTOWINDERSTAN	FOTORESISTENCIA	FOTORESISTENZA	
24	B. MEVR00320	01	ELECTRODES	ELECTRODES	ELEKTRODEN	ELECTRODOS	ELETTRODI	
25	I30685	01	WASHER	RONDELLE	DICHTUNG	ARANDELLA	RONDELLA	
26	I31034	01	NUT	ECROU	SCHRAUBMUTTER	TUERCA	DADO	
27	B. CRVR00706	01	COVER	COUVERCLE	DECKEL	TAPA	COPERCHIO	
28	B. CRAS00101	01	COVER	COUVERCLE	DECKEL	TAPA	COPERCHIO	THERMAL T30
28	B. CRVR00717	01	COVER	COUVERCLE	DECKEL	TAPA	COPERCHIO	THERMAL T40
29	B. CRZN00673	01	CYLINDER	CYLINDRE	ZYLINDER	CIINDRO	CILINDRO	THERMAL T40
29	B. CRVR00705	01	CYLINDER	CYLINDRE	ZYLINDER	CIINDRO	CILINDRO	THERMAL T30
30	B. CRZN00667	01	CYLINDER	CYLINDRE	ZYLINDER	CIINDRO	CILINDRO	THERMAL T30
30	B. P20214	01	CYLINDER	CYLINDRE	ZYLINDER	CIINDRO	CILINDRO	THERMAL T40
31	P20212	01	HEATING COIL	SERPENTIN	ROHRSCHLANGE	SERPENTIN	SERPENTINA	
32	B. CMSP00122	01	BOILER BOTTOM	FOND CHAUDIERE	KESSELBODEN	FONDO CALDERA	FONDO CALDAIA	
33	B. CRDS00764	01	COVER	COUVERCLE	DECKEL	TAPA	COPERCHIO	
34	M10804	04	TIE ROD	TIRANT	ZUGSTANGE	TIRANTE	TIRANTE	
35	L01235	01	COVER	COUVERCLE	DECKEL	TAPA	COPERCHIO	
36	I31037	02	RING NUT	FRETTE	NUTMUTTER	CASQUILLO	GHIERA	

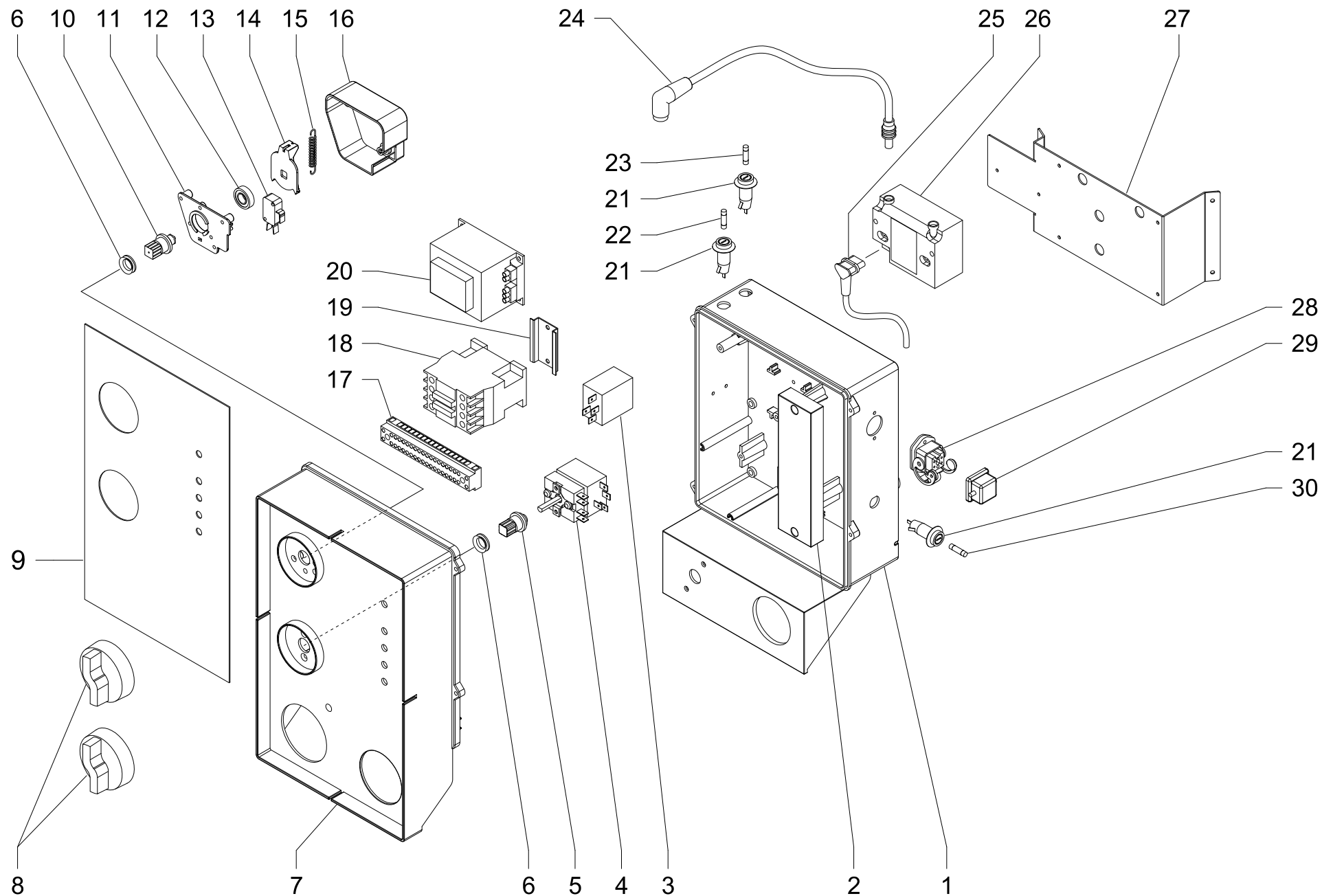

TABLE N° EXPL00150

## SPARE PARTS LIST

ELECTRIC PANEL THERMAL

01/07/2019

REF	CODE	QTY	DESCRIPTION	DENOMINATION	BESCHREIBUNG	DESCRIPCION	DESCRIZIONE	TECNICAL FEATURES		
01	B. PLDS00310	01	BOX	BOÎTE	KASTEN	CAJA	SCATOLA			
02	B. PLDS00312	01	COVER	COUVERCLE	DECKEL	TAPA	COPERCHIO			
03	B. MEIP00054	01	THERMOSTAT	THERMOSTAT	THERMOSTAT	TERMOSTATO	TERMOSTATO			
04	B. MEIP00051	01	THERMOSTAT	THERMOSTAT	THERMOSTAT	TERMOSTATO	TERMOSTATO			
05	B. CMMP00145	01	INSERT	INSERT	EINSATZ	INSERTO	INSERTO			
06	B. GUAR00112	02	GASKET	GARNITURE	DICHTUNG	GUARNICION	GUARNIZIONE			
07	B. PLDS00311	01	COVER	COUVERCLE	DECKEL	TAPA	COPERCHIO			
08	B. CMMP00110	02	KNOB	POIGNEE	VERSTELLGRIFF	MANOPOLA	MANOPOLA			
09	B. ETIC00168	01	LABEL	ETIQUETTE	ETIKETT	ETIQUETA	ETICHETTA			
10	B. CMMP00149	01	INSERT	INSERT	EINSATZ	INSERTO	INSERTO			
11	B. PLDS00327	01	SUPPORT	SUPPORT	HALTER	SOPORTE	SUPPORTO			
12	B. CUSC00032	01	BEARING	ROULEMENT	LAGER	COJINETE	CUSCINETTO			
13	B. MEIP00057	01	SWITCH	INTERRUPTEUR	SCHALTER	INTERRUPTOR	INTERRUTTORE			
14	B. PLDS00328	01	LEVER	LEVIER	HEBEL	PALANCA	LEVA			
15	B. MOLL00046	01	SPRING	RESSORT	FEDER	MUELLE	MOLLA			
16	B. PLDS00329	01	COVER	COUVERCLE	DECKEL	TAPA	COPERCHIO			
17	B. MEVR00317	01	CONNECTOR	CONNECTEUR	STECKER	CONECTADOR	CONNETTORE			
18	B. METR00021	01	CONTACTOR	CONTACTEUR	FERNSCHALTER	CONTACTOR	TELERUTTORE			
19	B. CRZN00663	01	SUPPORT	SUPPORT	HALTER	SOPORTE	SUPPORTO			
20	B. METR00020	01	TRANSFORMER	TRANSFORMATEUR	TRANSFORMER	TRANSFORMADOR	TRASFORMATORE			
21	B. MEVR00318	03	FUSE-HOLDER	PORTE-FUSIBLES	SICHERUNGHALTER	PORTASFUSIBLES	PORTAFUSIBILE			
22	E10326	01	FUSE	FUSIBLE	ABSCHMEL.HERUNG	FUSIBLE	FUSIBILE	0,5 A		
23	E10328	01	FUSE	FUSIBLE	ABSCHMEL.HERUNG	FUSIBLE	FUSIBILE	1,6 A		
24	B. MECV00062	02	CABLE	CABLE	KABEL	CABLE	CAVO			
25	B. MECV00063	01	CABLE	CABLE	KABEL	CABLE	CAVO			
26	B. METR00018	01	TRANSFORMER	TRANSFORMATEUR	TRANSFORMER	TRANSFORMADOR	TRASFORMATORE			
27	B. CRVR00707	01	SUPPORT	SUPPORT	HALTER	SOPORTE	SUPPORTO			
28	E20640	01	CONNECTOR	CONNECTEUR	STECKER	CONECTADOR	CONNETTORE			
29	B. MECN00068	01	COVER	COUVERCLE	DECKEL	TAPA	COPERCHIO			

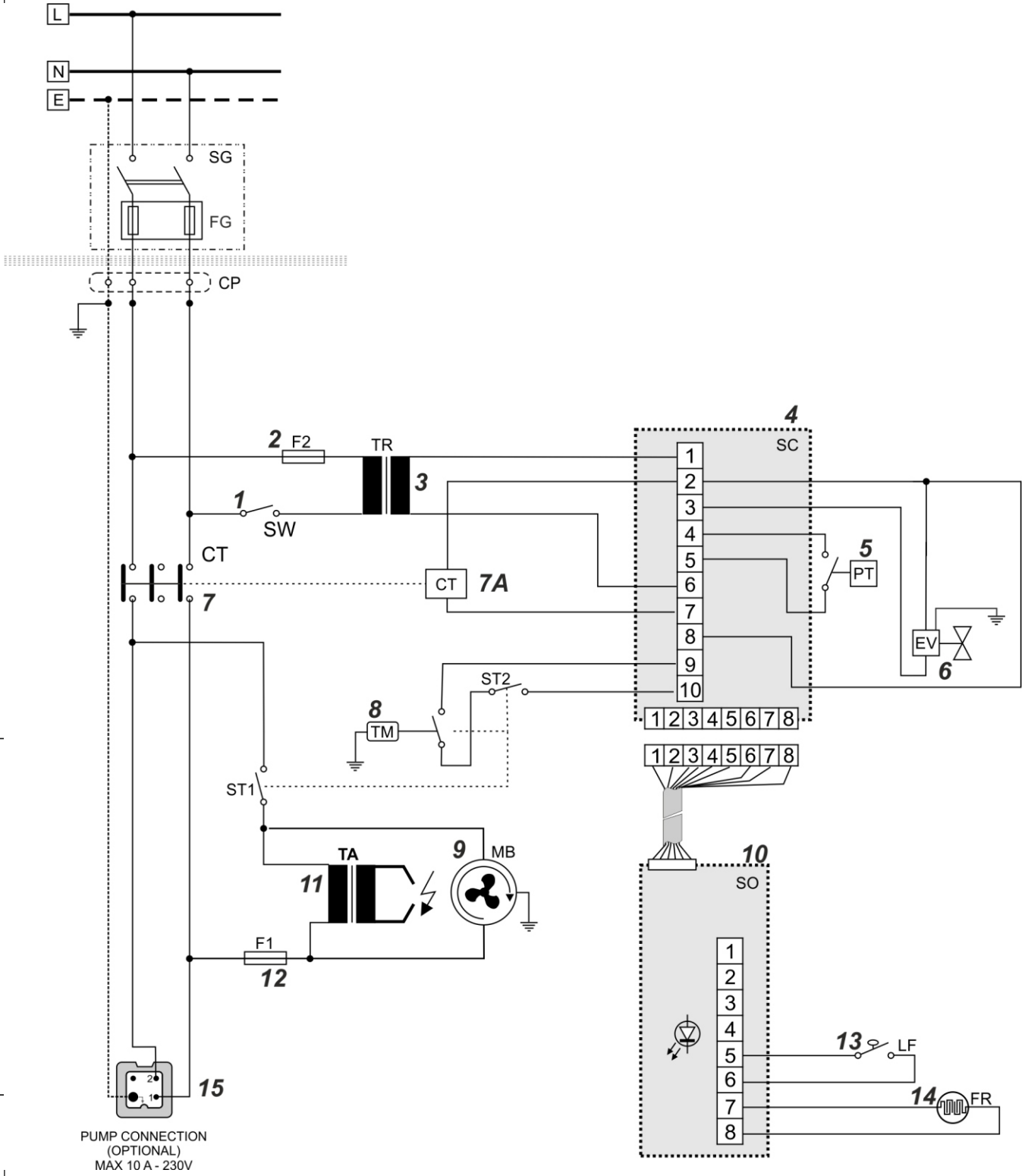

PUMP CONNECTION  
(OPTIONAL)  
MAX 10 A - 230V

TABLE N° EXPL00151

## SPARE PARTS LIST

EL. DIAGRAM THERMAL

02/09/2016

REF	CODE	QTY	DESCRIPTION	DENOMINATION	BESCHREIBUNG	DESCRIPCION	DESCRIZIONE	TECNICAL FEATURES		
01	B. MEIP00057	01	SWITCH	INTERRUPTEUR	SCHALTER	INTERRUPTOR	INTERRUPTORE	0,5 A		
02	B. E10326	01	FUSE	FUSIBLE	ABSCHMEL.HERUNG	FUSIBLE	FUSIBILE			
03	B. METR00020	01	TRANSFORMER	TRANSFORMATEUR	TRANSFORMER	TRANSFORMADOR	TRASFORMATORE			
04	B. MESC00017	01	ELEC. CIRCUIT	CIRQUIT. ELECT.	ELEKTR. STROM.	CIRCUITO ELECT.	SCHEDA			
05	B. MEIP00052	01	PRESSURE SWITCH	PRESSOSTAT	DRUCKSCHALTER	INTERR. PRESIÓN	PRESSOSTATO			
06	B. METR00019	01	COIL	BOBINE	SPULE	BOBINA	BOBINA			
07	B. METR00032	01	CONTACTOR	CONTACTEUR	FERNSCHALTER	CONTACTOR	TELERUTTORE	1,6 A FUEL		
08	B. MEIP00051	01	THERMOSTAT	THERMOSTAT	THERMOSTAT	TERMOSTATO	TERMOSTATO			
09	E10697	01	MOTOR	MOTEUR	MOTOR	MOTOR	MOTORE			
10	B. MESC00018	01	ELEC. CIRCUIT	CIRQUIT. ELECT.	ELEKTR. STROM.	CIRCUITO ELECT.	SCHEDA			
11	B. METR00018	01	TRANSFORMER	TRANSFORMATEUR	TRANSFORMER	TRANSFORMADOR	TRASFORMATORE			
12	E10328	01	FUSE	FUSIBLE	ABSCHMEL.HERUNG	FUSIBLE	FUSIBILE			
13	B. MEIP00048	01	SWITCH	INTERRUPTEUR	SCHALTER	INTERRUPTOR	INTERRUPTORE	1,6 A FUEL		
14	B. PMVR00174	01	PHOTORESISTANCE	PHOTORESISTANCE	PHOTOWINDERSTAN	FOTORESISTENCIA	FOTORESISTENZA			
15	B. E20614	01	CONNECTOR	CONNECTEUR	STECKER	CONECTADOR	CONNETTORE			







---

BIEMMEDUE S.p.A. - Via Industria, 12 - 12062 - CHERASCO (CN) - Italy  
Tel. +39 0172 486111 - Fax +39 0172 488270  
[www.biemmedue.com](http://www.biemmedue.com) - e-mail: [bm2@biemmedue.com](mailto:bm2@biemmedue.com)