

**1**



**Sollevamento motore**  
**Lifting the engine**  
**Levage moteur**  
**Levantamiento del motor**  
**Anheben des Motors**

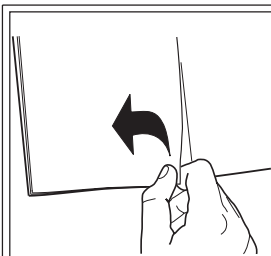
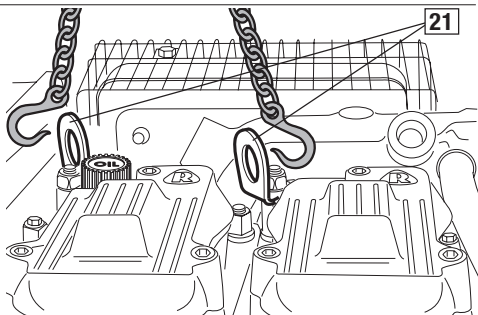

fig. **2** ..... fig. **24**

**CONTENTS**

PREFACE .....	20
GENERAL SERVICE MANUAL NOTES .....	20
NOTES REGARDING THE INSTRUCTION AND MAINTENANCE HANDBOOK .....	20
GENERAL SAFETY REGULATIONS .....	21
GENERAL REGULATIONS FOR EPA VERSION ENGINES .....	23
WARRANTY CERTIFICATE .....	24
MD SERIES DIESEL ENGINE TECHNICAL SPECIFICATIONS .....	25
ENGINE DIAGRAM (figure 1, cover) .....	25
ENGINE IDENTIFICATION .....	26
ELECTRICAL EQUIPMENT .....	26
RUGGERINI SERVICE .....	26
CONSUMABLE MATERIALS .....	27
Lubricants .....	27
Fuel .....	27
Filters .....	27
PRELIMINARY CHECKOUT .....	28
Checking the oil level in the engine .....	28
Checking the oil bath air filter .....	28
Fuel check .....	28
Other checks .....	28
OPERATION .....	28
Electric start .....	28
Recoil starting system .....	29
Manual start .....	29
Engine heating .....	29
Run-in .....	29
Engine stop .....	29
MAINTENANCE .....	30
Air filter .....	31
Fuel filter .....	31
Engine oil change .....	32
Cooling system cleaning .....	32
Valve clearance .....	32
Injectors cleaning and set-up .....	32
Partial overhaul .....	32
General overhaul .....	32
STORAGE .....	33
Storage up to 6 months .....	33
Storage for over 6 months .....	33
Preparing the engine for operation .....	33
TROUBLESHOOTING .....	34
ILLUSTRATIONS .....	cover
ELECTRICAL WIRING DIAGRAM .....	83

**PREFACE**

Every attempt has been made to present within this service manual, accurate and up to date technical information. However, development on the Ruggerini series is continuous. Therefore, the information within this manual is subject to change without notice and without obligation.

The information contained within this service manual is the sole property of Ruggerini. As such, no reproduction or replication in whole or part is allowed without the express written permission of Ruggerini.

Information presented within this manual assumes the following:

- The person or persons performing service work on Ruggerini series engines is properly trained and equipped to safely and professionally perform the subject operation;
- The person or persons performing service work on Ruggerini series engines possesses adequate hand and Ruggerini special tools to safely and professionally perform the subject service operation;
- The person or persons performing service work on Ruggerini series engines has read the pertinent information regarding the subject service operations and fully understands the operation at hand.

**GENERAL SERVICE MANUAL NOTES**

- Use only genuine Ruggerini repair parts. Failure to use genuine Ruggerini parts could result in sub-standard performance and low longevity.
- All data presented are in metric format. That is, dimensions are presented in millimeters (mm), torque is presented in Newton-meters (Nm), weight is presented in kilograms (Kg), volume is presented in liters or cubic centimeters (cc) and pressure is presented in barometric units (bar).

**NOTES REGARDING THE INSTRUCTION AND MAINTENANCE HANDBOOK****DANGER!**

*Indicates particularly delicate and/or dangerous procedures. Negligent behaviour by the operator may cause injuries to the operator him/herself or to others!*

**WARNING!**

*Indicates procedures in which negligence can damage the machine and/or the system!*

**Ruggerini SERVICING**

*Indicates difficult operations for which the intervention of a Ruggerini Service Centre is suggested (a complete list may be found on the "World Service Organisation" booklet provided with the engine).*

**SERVICE**

*Indicates the headquarters of the Ruggerini Service (ph. +39 0522 389371, fax +39 0522 389433, e-mail [service@ruggerini.it](mailto:service@ruggerini.it)).*

***The instructions found in this handbook refer to the basic configuration of the engine only. All control devices mentioned herein (accelerator, stop, electric controls) control the engine. Your machine may have different devices fulfilling the same functions as the devices described in this handbook.***

***We therefore advise you to read through the specific instructions for your machine as well as this handbook.***



## GENERAL SAFETY REGULATIONS

---

- Ruggener engines are built to provide safe and longlasting performances, but in order to obtain these results it is essential that the maintenance requirements described in the manual are observed along with the following safety recommendations.
- The engine has been built to the specifications of a machine manufacturer, and it is his responsibility to ensure that all necessary action is taken to meet the essential and legally prescribed health and safety requirements. Any use of the machine other than that described cannot be considered as complying with its intended purpose as specified by Ruggener, which therefore declines all responsibility for accidents caused by such operations.
- The following instructions are intended for the user of the machine in order to reduce or eliminate risks, especially those concerning the operation and standard maintenance of the engine.
- The user should read these instructions carefully and get to know the operations described. By not doing so he may place at risk his own health and safety and that of anyone else in the vicinity of the machine.
- The engine may be used or mounted on a machine only by personnel suitably trained in its operation and aware of the dangers involved. This is particularly true for standard and, above all, special maintenance work. For special maintenance contact personnel trained specifically by Ruggener. This work should be carried out in accordance with existing literature.
- Ruggener declines all responsibility for accidents or for failure to comply with the requirements of law if changes are made to the engine's functional parameters or to the fuel flow rate adjustments and speed of rotation, if seals are removed, or if parts not described in the operating and maintenance manual are removed and reassembled by unauthorized personnel.
- An over-revving diesel engine is difficult to control. In some cases this may injure people and cause damage to objects. To avoid over-revving we suggest:
  - not to exceed the MAX oil level in the engine oil sump,
  - do not exceed the MAX oil level in the air filter float chamber,
  - do not exceed the maximum working gradient as found on the operation and maintenance handbooks,
  - position the engine horizontally,
  - do not modify the manufacturer's settings,
  - do not tamper with the fuel injector.
- In addition to all other machine specifications, ensure that the engine is in a near horizontal position when starting. If starting manually, ensure that the necessary operations can be performed without any risk of striking against walls or dangerous objects. Rope starting (except for recoil rope starting) is not permitted even in emergencies.
- Check that the machine is stable so that there is no risk of it overturning.
- Get to know the engine speed adjustment and machine stop operations.
- Do not start the machine in closed or poorly ventilated environments. The internal combustion process generates carbon monoxide, an odourless and highly toxic gas, so spending too long a time in an environment where the engine discharges its exhaust products freely can lead to loss of consciousness and even death.
- The engine may not be used in environments containing flammable materials, explosive atmospheres or easily combustible powders, unless adequate and specific precautions have been taken and are clearly stated and certified for the machine.
- To prevent the risk of fire, keep the machine at a distance of at least one metre from buildings or other machines.
- Children and animals must be kept at a sufficient distance from the machine to prevent any danger resulting from its operation.
- Fuel is flammable, so the tank must be filled only when the engine is turned off. Dry carefully any fuel that may have spilled, remove the fuel container and any cloths soaked in fuel or oil, check that any sound-absorbing panels made of porous material are not soaked with fuel or oil, and make sure that the ground on which the machine is located has not absorbed fuel or oil.

- Close the fuel tank filler cap carefully after each filling operation. Do not fill the tank right up to the top, but leave sufficient space to allow for any expansion of the fuel.
- Fuel vapours are highly toxic, so fill up only in the open air or in well ventilated environments.
- Do not smoke or use naked flames while filling.
- To start the engine follow the specific instructions provided in the engine and/or machine operating manual. Do not use auxiliary starting devices not originally installed on the machine (e.g. Startpilot systems which utilise ether etc.)
- Before starting, remove any tools that have been used for carrying out maintenance work to the engine and/or the machine and check that any guards removed have been replaced. In cold climates it is possible to mix kerosene with the diesel fuel to make the engine easier to start. The liquids must be mixed in the tank by pouring in first the kerosene and then the diesel fuel. Consult Ruggerini technical office for mixture proportions. Petrol may not be used because of the risk of it forming flammable vapours.
- During operation the surface of the engine reaches temperatures that may be dangerous. Avoid in particular all contact with the exhaust system.
- Before carrying out any work on the engine, turn it off and allow it to cool down. Do not perform any operation while the engine is running.
- While cleaning the oil bath air filter, check that the oil is disposed of in such a way as not to harm the environment. Any filtering sponges in the oil bath air filter should not be soaked with oil. The cyclone pre-filter cup must not be filled with oil.
- Since the oil must be emptied out while the engine is still hot (approx. 80°C), particular care should be taken in order to avoid burns. In any case make sure that oil does not come into contact with your skin because of the health hazards involved.
- Check that the discharged oil, the oil filter and the oil contained in the oil filter are disposed of in such a way as not to harm the environment.
- Take care when removing the oil filter as it may be hot.
- During operations which involve access to moving parts of the engine and/or removal of the rotary guards, disconnect and insulate the positive cable of the battery so as to prevent accidental short circuits and activation of the starter motor.
- Check the belt tension only when the engine is turned off.
- In order to move the engine use exclusively the eyebolts fitted for this purpose by Ruggerini. These lifting points are however not suitable for the entire machine, so in this case use the eyebolts fitted by the manufacturer.

**GENERAL REGULATIONS FOR EPA VERSION ENGINES**

EPA version engines are subject to the regulations issued by the EPA (Environmental Protection Agency).



*In order to keep the engine in full compliance with the emission standards provided for by the above-mentioned regulation, strictly observe the advice and recommendations specified in this manual.*

**In particular, keep to the following instructions:**

- Do not change the settings carried out by the Manufacturer
- Run the engine within the power and speed limits provided for by the Manufacturer
- Carefully carry out maintenance as indicated in the relevant table
- Immediately refer to a Ruggnerini after-sales service in the event that anomalies are noticed, especially in case the grade of smoke should change.
- Use Ruggnerini original spare parts only

**Regarding emissions, the Manufacturer is no longer liable in the event that:**

- Ruggnerini deems the engine application or installation inadequate.
- The engine is altered, or fitted with equipment that is not supplied nor approved by Ruggnerini.
- The user fails to upkeep the engine as provided for by the Manufacturer.
- The engine use exceeds the limits provided for by the Manufacturer.
- The user notifies any failure to the Ruggnerini after-sales service with unreasonable delay.



EPA-approved engines can be identified by the appropriate nameplate placed on the air shroud.

## **WARRANTY CERTIFICATE**

---

Products Ruggerini Motori manufactured by Lombardini Srl are warranted to be free from non-conformity defects for a period of 24 months from the date of delivery to the first end user.

For engines fitted to stationary equipment, working at constant load and at constant and/or slightly variable speed within the setting limits, the warranty covers a period up to a limit of 2000 working hours, if the above mentioned period (24 months) is not expired.

If no hour-meter is fitted, 12 working hours per calendar day will be considered.

For what concerns the parts subject to wear and deterioration (injection/feeding system, electrical system, cooling system, sealing parts, non-metallic pipes, belts) warranty covers a maximum limit of 2000 working hours, if the above-mentioned period (24 months) is not expired.

For correct maintenance and replacement of these parts, it is necessary to follow the instructions reported in the documentation supplied with each engine.

To ensure the engine warranty is valid, the engine installation, considering the product technical features, must be carried out by qualified personnel only.

The list of the Lombardini authorized dealers for Ruggerini Motori products is reported in the "World Service Organisation" booklet, supplied with each engine.

Special applications involving considerable modifications to the cooling/lubricating system (for ex.: dry oil sump), filtering system, turbo-charged models, will require special written warranty agreements.

Within the above stated periods Lombardini Srl directly or through the Ruggerini Motori authorized network will repair and/or replace free of charge any own part or component that, upon examination by Ruggerini Motori Service Dept. or by an authorized Ruggerini Motori agent, is found to be defective in conformity, workmanship or materials.

Any other responsibility/obligation for different expenses, damages and direct/indirect losses deriving from the engine use or from both the total or partial impossibility of use, is excluded.

The repair or replacement of any component will not extend or renew the warranty period.

Lombardini Srl warranty obligations here above described will be cancelled if:

- Engines are not correctly installed and as a consequence the correct functional parameters are not respected and altered.
- Engines are not used according to the instructions reported in the "Use and Maintenance" booklet supplied with each engine.
- Any seal affixed to the engine by the Manufacturer has been tampered with or removed.
- Spare parts used are not original from Manufacturer.
- Feeding and injection systems are damaged by unauthorized or poor quality fuel types.
- Electrical system failure is due to components, connected to this system, which are not supplied or installed by the Manufacturer.
- Engines have been disassembled, repaired or altered by any part other than an authorized Ruggerini Motori agent.

Following expiration of the above stated warranty periods and working hours, Lombardini will have no further responsibility for warranty and will consider its here above mentioned obligations for warranty complete.

Any warranty request related to non-conformity of the product must be addressed to the Ruggerini Motori service agents.



**MD SERIES DIESEL ENGINE TECHNICAL SPECIFICATIONS**

MODEL		MD150/151	MD170/171	MD190/191	MD190E/191E
Cycle		diesel 4-stroke type			
Fuel injection		direct			
Cooling system		forced air, with fan flywheel			
Fuel supply		gravity feed or with AC pump			
Lubrication		forced, with lobe pump			
Governor		flyweight-type governor			
Number of cylinders		2			
Displacement	cm <sup>3</sup>	654	737	851	851
Bore	mm	80	85	85	85
Stroke	mm	65	65	75	75
RPM (engine)		3000(MD150) 3600(MD151)	3000(MD170) 3600(MD171)	3000(MD190) 3600(MD191)	3000(MD190E) 3600(MD191E)
Compression rate		19:1	19:1	19:1	20:1
Power take-off rotation direction		anticlockwise			
Max. torque	Nm(rpm)	32(2400)	34(2400)	40.5(2400)	40.5(2400)
Suggested battery		12V-60Ah-300A	12V-60Ah-300A	12V-70Ah-320A	12V-70Ah-320A
Maximum inclination non continuous (continuous) gradient		35° (25°) - power take-off side 30° (25°) - pulley side 40° (25°) - lateral			
Dry weight	kg	50	71	53	53
Oil sump capacity (opt.)	Litres	1,8 (2,8)			
Tank capacity (std)	Litres	4			



Do not run the engine on floors with gradients above the maximum values indicated in the "Technical Specifications" table.

The engine will have a 2% power loss for every additional 5 °C increase over 20 °C (+68 °F) and a 1% power loss for every 100 metres above sea level.



In case of particularly difficult installations, contact Rugggerini Service.

**ENGINE DIAGRAM (figure 1, cover)**

- |                                    |                                     |
|------------------------------------|-------------------------------------|
| 1. Engine identification nameplate | 11. Starter                         |
| 2. Oil filter plug                 | 12. Silencer                        |
| 3. Engine stop lever               | 13. Air filter                      |
| 4. External oil filter             | 14. Rocker-arm cover                |
| 5. Oil filler plug                 | 15. Fuel tank cap                   |
| 6. Throttle lever                  | 16. Fuel tank                       |
| 7. Oil dipstick                    | 17. Fuel filter                     |
| 8. Air shroud                      | 18. Drive                           |
| 9. Flywheel mesh screen            | 19. Oil sump                        |
| 10. Crankcase                      | 20. Oil drain plug                  |
|                                    | 21. Eye bolt for engine lifting (*) |

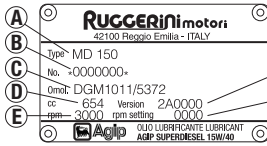

(\*) The eyebolt must be only used to lift the engine and not the whole machine!

**ENGINE IDENTIFICATION**

The engine identification plate is located on the air conveyer (1, figure 1).

- A=** (Type) engine type  
**B=** (No.) engine serial number  
**C=** (Osmol.) type approval code  
**D=** (cc) displacement in cm<sup>3</sup>  
**E=** (rpm) standard RPM  
**F=** (Version) version  
**G=** (rpm setting) special RPM setting

**ELECTRICAL EQUIPMENT**

The wiring diagram can be found in figure 25 on page 83.

1. Ignition key (optional)
2. Voltage regulator
3. Engine starter
4. Battery (not included)
5. Alternator
6. Pressure switch
7. Battery recharge warning light (optional)
8. Oil pressure warning light (optional)

**RUGGERINI SERVICE**

Correct and constant maintenance of the engine is an essential condition to ensure its endurance, thus reducing operating costs.



To request servicing or spare parts, contact one of the authorised Service Centres listed in the **"WORLD SERVICE ORGANISATION"** booklet you will find inside the bag containing the accessories, specifying:

- all data found on the engine identification plate,
- kind of intervention.

For any further information, contact Ruggerini Service.

**CONSUMABLE MATERIALS**

---

**• Lubricants**

*The engine is supplied without oil. Use quality lubricants, carbon deposits in the lubrication ducts may result in engine sizing.*

*Nothing affects the performance and durability of your engine more than the lube oil you use. If inferior oil is used, or if your engine oil is not changed regularly, the risk of piston seizure, piston ring sticking, and accelerated wear of the cylinder liner, bearing and other moving components increases significantly.*

Use diesel engine lubricants complying with API SJ/CF specifications or oil corresponding to the military specification MIL-L-2104E. Choose the proper oil to be used according to the room temperatures shown in diagram - figure 2. AGIP Superdiesel multigrade 15W-40 ACEA E2, B2 MIL-L-2104E.

If the engine is used below -15°C, use SAE 5W/30 oil.



***The used engine oil can cause skin-cancer if kept frequently in contact for prolonged periods. If contact with oil cannot be avoided, wash carefully your hands with water and soap as soon as possible. Do not disperse the oil in the ambient, as it has a high pollution power.***

**• Fuel**

*Use the same type of diesel fuel as used in cars. Use of other types of fuel could damage the engine.*

*The cetane rating of the fuel must be higher than 45 to prevent difficult starting.*

*With low ambient temperature (-10 °C) add specific additives to diesel fuel, to avoid paraffine crystals solidification.*

*The presence of impurities such as sulphur, water and dirt in the diesel oil can seriously damage the correct operation of the fuel injection pump, especially when the engine is not used for long periods of time (see "storage" paragraph on page 33).*

*When refuelling, it is advisable to use a funnel to prevent fuel from spilling out. The fuel should also be filtered to prevent dust or dirt from entering the tank.*



***To avoid explosions or fire outbreaks, do not smoke or use naked flames during the operations.***

***Fuel vapours are highly toxic. Only carry out the operations outdoors or in a well ventilated place.***

***Keep your face well away from the plug to prevent harmful vapours from being inhaled. Dispose of fuel in the correct way and do not litter as it is highly polluting.***

**• Filters**

*Use original spare parts only. The warranty terminates in case of use or maintenance not consistent with Ruggeneri's prescriptions.*

## PRELIMINARY CHECKOUT

---

- **Checking the oil level in the engine**

Before starting the engine, check the oil level (figure 3). If the level is below the minimum, Remove the oil filling cap, pour the oil (figure 21-22), check the level again and refit the cap.



*Make sure that it is at max with engine on level surface. The engine may be damaged if operated with insufficient lube oil.*



**Caution! Never exceed the MAX level. It is dangerous to supply too much lube oil to the engine because a sudden increase in engine rpm could be caused by its combustion.**

- **Checking the oil bath air filter**

Unhook lock "A", figure 4, remove the filter element and pour engine oil up to the level (figure 5). Reassemble the filter.



*Make sure that the filter is mounted in the correct way otherwise dust and other impurities could infiltrate into the intake ducts.*



**Do not exceed the level shown in the filter when adding oil. The extra oil might be sucked by the engine thus causing a sudden increase in the rotation speed.**

- **Fuel check**

Loosen cap "A", (figure 6) and sight-check the level of fuel.



*Do not fill the fuel tank completely , but just up to 1 cm (0.39 in) from the top of the tank, to provide space for fuel movement. Wipe any fuel spillage from engine before starting.*

- **Other checks**



**Before starting the engine we suggest you to read with care the instructions which are not included in this booklet, but which your Retailer should have supplied you together with the machine you have bought. These contain precise instructions about the machine and, in particular, on safety devices or precautions.**

## OPERATION

---



**The engine must not be used in a closed environment unless the room is adequately ventilated. Combustion engines produce harmful gases which, in closed and/or insufficiently aired environments, can reach concentrations that may prove dangerous and/or lethal to people and animals. Protections for pulleys, belts and propeller shafts do not always ensure the operator's full safety; in particular, loose clothes may be trapped in the transmission parts causing serious harm to people! Do not tamper with the engine in order to improve its performance, the only consequence would be that of increasing risks.**

- **Electric start**



**Before starting the engine make sure that all connections with the machine (gearbox, clutch, etc.) are disconnected.**

Bring the accelerator lever to half stroke ("A", figure 7). Turn the ignition key (figure 8) to position "B", then start the engine turning it to position "C". Once the engine has been started, turn the ignition key back to position "B" (battery recharge) and bring the accelerator lever to the minimum position.



*Do not turn the key to position “C” (start) if the engine is running. In engines without solenoid valve stop, if the ignition key is turned to the “A” position (figure 8) when running, the voltage regulator components could be damaged. If the fuel circuit is empty or if the temperature is too low, several attempts may be necessary before the engine starts. In such cases, wait 15 seconds before trying any further attempt otherwise the starter could be overheated.*

• **Recoil starting system**

Accelerate the engine until it reaches half speed (“A”, figure 7). Pull the cord until compression is engaged. Operate the decompression lever (figure 9). The lever shall always be kept engaged during starting . Introduce the cord into its seat, then pull vigorously (figure 10).

• **Manual start**

Bring the accelerator lever to half stroke (“A”, figure 7). Turn the pulley anticlockwise up to the compression (figure 11), wind the rope around the pulley and **pull hard** (figure 12).



**Caution! Follow the above instructions. Manual start may prove dangerous if carried out by unskilled personnel!**

**Use the rope supplied with the engine. Replace it immediately if it shows signs of wear or deterioration. Do not wind the rope around your hand and remember that while pulling it must be perpendicular to the axis of rotation of the pulley. It is extremely important to check that there are no dangerous obstructions near the machine before starting the engine. This will avoid accidents and will allow easy movement, thus allowing the engine to operate at its best!**

• **Engine heating**



*We advise you against carrying out loadless heating procedures, particularly if heating takes a long time, as they may cause bad combustion and, consequently, high levels of smoke and oil spillage into the exhaust, and therefore gas pollution.*

• **Run-in**

Follow the rules below during the run-in period (approximately 50 hours):



- *pre-heat the engine for several minutes before loading;*
- *use the engine only partially laden;*
- *do not overload the engine for long periods;*
- *do not insist in using the machine if black smoke is exhausted;*
- *before stopping the engine idle for some minutes to cool it down.*

We suggest replacing the engine oil and the oil cartridge at the end of the run-in period (50 hours).





• **Engine stop**

Bring the accelerator lever to the minimum (“A”, figure 7), wait for a few seconds, push the engine stop lever to the STOP position (“B”, figure 7) and keep it pressed until the engine stops completely. If the engine is fitted with a solenoid valve stop, turn the ignition key to position “A” (figure 8).



*Do not stop the engine when operating at full load or high speed. Before stopping it. Let it run for a short time at low idle.*

**MAINTENANCE**

PROCEDURE	8h	50h	200h	300h	400h	2500h	5000h
Checking engine oil level	●						
Checking and/or cleaning air filter	●						
Air filter oil renewal		●					
Dry-type air filter replacement			●				
Replacing fuel cartridge			●				
Engine oil renewal		■	●				
Internal oil filter cleaning			●				
Internal oil filter renewal						●	
Replacing oil cartridge (MD190 or optional)		■	●				
Cooling system cleaning (and MD190 radiator)			●				
Checking valve clearance							
Cleaning and setting up the injectors							
Partial overhaul							
General overhaul							

■ First oil renewal and cartridge replacement

 Operations to be carried out at Ruggerini Service Centres

The maintenance operations listed above refer to an engine operating in normal conditions (temperature, degree of humidity, dust in the working environment). They may vary significantly according to the type of use.



*It is the operator's responsibility to adapt maintenance to particularly difficult environmental and working conditions. Contact Ruggerini Service in case of need.*

*If the engine is not used for long periods of time (4-6 months), the engine oil must be replaced when re-starting, even if the engine has only been used for a few hours, as oil tends to oxidise and lose its lubricating properties.*



**Maintenance should be carried out by experts. Some operations might look simple but could be dangerous if carried out without adequate precautions. Ruggerini Service Centres will give you all indications or suggestions you may need to carry out correct maintenance. In case of failure, they will supply you with original spare parts complying with the manufacturer's specifications. Read carefully the GENERAL SAFETY REGULATION on pages 21 and 22 before working on the engine.**



**Do not carry out any maintenance with the engine running! Make sure the machine is safely placed. Remove ignition key and make sure the engine cannot be started anyway.**

- **Air filter**

- **Oil bath air filter**

Unhook lock "A", figure 4, take out the bottom air filter bowl, wash all parts with care using diesel oil (figure 13) and dry them using compressed air. Before assembly fill the float chamber with engine oil up to the level mark (figure 4-5).



**Do not exceed the level shown in the filter when adding oil. The extra oil might be sucked by the engine thus causing a sudden increase in the rotation speed.**

**Always use protective goggles when compressed air is used.**

**Never use solvents with a low flash point to clean the filter element. Such action could cause an explosion.**

- **Dry-type air filter (optional):**

Open the filter housing and check the filter conditions every day (figure 14). In any case, the cartridge must be replaced every 200 hours.



*Make sure that the filter is mounted in the correct way otherwise dust and other impurities could infiltrate into the intake ducts.*

*Clean the air filter frequently, as dust particles can wear the internal parts of the engine (cylinder, piston, crankshaft, pivots, etc.) very quickly (in just a few operation hours). If the working area is very dusty, change the oil in the filter every 4-5 working hours. Choose filters which are adequate for the specific operating conditions.*

- **Fuel filter**

- **Internal fuel filter:**

In the standard version, the oil filter is housed inside the fuel tank:

- Empty the tank completely;
- Loosen the seal screw (figure 15);
- Replace the cartridge.

- **External fuel filter:**

- drain the fuel tank completely;
- remove the cartridge (figure 16) by rotating it anticlockwise;
- fill the new cartridge with diesel oil and screw it on tightening it manually.

Original Ruggerini cartridges are recommended.

If the fuel supply circuit is empty, it is not necessary to purge the air as the engine is supplied with an automatic air relief valve.



*The engine might not start immediately as the circuit must fill up first: before starting, use the manual pump lever found on the fuel supply pump (figure 17) to fill up the circuit. Do not attempt to start the engine repeatedly using the starter. Follow recommendations regarding electric start on page 28.*

*The breather pipe and the thread of the fuel tank cap should be checked regularly to verify that they are free of impurities ("B", figure 6), particularly if the machine is operated in a dusty environment.*



**Do not throw away spent cartridges, but hand them to specialised waste disposal centres.**

• **Engine oil change**

Let the engine run for a few minutes at minimum RPM then stop it, remove the cap and drain the oil (figure 18).

- **Version with internal oil filter:**

- Remove the internal oil filter plug ("1" Fig. 19);
- Take out the filter ("2" figure 19), clean it with a brush and diesel fuel, and then reassemble it.

The filter must be replaced every 400 hours of operation.

- **Version with external oil filter:**

- Remove the cartridge (figure 20) by turning it anticlockwise;
- Fill the new cartridge with oil, and then screw it by tightening it manually.

Original Ruggerini cartridges are recommended.

Refit cap (figure 18), fill with oil (figure 21-22) and check oil level (figure 23).



*Before restarting, make sure that the oil dipstick and the oil drain and fill plugs have been correctly fitted back in place to prevent lubricant from spilling out. Original Ruggerini cartridges are recommended.*



**CAUTION! Hot oil can cause serious burns.**

**Do not throw away spent oil and cartridges, but hand them to specialised waste disposal centres.**

• **Cooling system cleaning**



*In the event that the engine runs in a dusty area or that grass, hay, sand etc. are trapped in it, clean carefully the whole cooling system (fan flywheel, air ducts, cylinder cooling fins, cylinder heads and oil radiator, where present). Cleaning may be carried out by blowing compressed air or using diesel fuel periodically: in this case dry with compressed air (figure 24).*



**Always use protective goggles when compressed air is used.**

**Never use solvents with a low flash point to clean the filter element. Such action could cause an explosion.**

• **Valve clearance**



Set the valve clearance with engine cold during the compression phase and with the piston at Top Dead Centre. The play must be set at 0.15 mm.

• **Injectors cleaning and set-up**



Every 300 hours of operation or in case of increase in the grade of smoke at the exhaust pipe, clean and check the injector settings.

• **Partial overhaul**



The partial overhaul includes the following operations: valve and seat lapping, injector and injection pump overhaul, injector projection check, fuel injection spark advance check, check of the harmful area between head and piston, camshaft and crankshaft end float check, tightening of bolts.

• **General overhaul**



The general overhaul includes - in addition to all partial overhaul - the following procedures: cylinder and piston replacement, seat, guide and valve refacing, crankshaft replacement or grinding, bench bearing and connecting rod replacement.



*The following operations must be carried out at a Ruggerini Service Centre: valve clearance check, injector clean-up, partial overhaul and general overhaul. The above maintenance rules must be followed scrupulously. Warranty terminates if maintenance does not comply with Ruggerini's indications.*



## STORAGE



*The most delicate parts of the engines such as the injection system, the rubber parts, the seal systems etc., are often subject to malfunction or deterioration in case of long off-duty period and/or especially in case of lack of a suitable protection. This is more evident if the engines are off duty in adverse weather conditions (humidity, very high or low temperatures, bad weather, etc.).*

### • **Storage up to 6 months**

- idle the engine for approximately 15 minutes, then stop it;
- replace the fuel filter;
- add diesel oil and 10% AGIP RUSTIA 81 protective oil mixture;
- let the engine run for approximately 10 minutes at a speed between 1/2 and 3/4 rated revolutions, so that the piping, injectors, pumps and filters are filled with the protective mixture, then stop it;
- spray AGIP RUSTIA C SAE 30 oil in the exhaust and intake ducts;
- clean the fins and the external parts of the engine with care and protect external non-painted surfaces with AGIP RUSTIA C SAE30 oil;
- seal the muffler and the air filter using adhesive tape;
- wrap the engine in a plastic sheet.

### • **Storage for over 6 months**

In addition to the above-mentioned operations, the following procedures must be carried out:

- wash the oil filter;
- change the engine oil with AGIP RUSTIA C SAE 30;
- regularly inspect the engine and check that no rust or corrosion spots appear. Should this happen, contact a Ruggerini Service Centre.

### • **Preparing the engine for operation**

- remove the protection cover;
- remove the external protection using a solvent or degreaser;
- check injector settings and valve clearance and make sure that the heads and filters are tight;
- carry out ordinary preliminary checkout procedures;
- if AGIP RUSTIA C SAE 30 protective oil has been used, change it before the engine reaches 100 working hours.



*Caution! If the engine has not been protected as described above, as a consequence of long period inactivity the fuel injector pump and injectors may jam and piston rings may stick together. This may result in re-starting troubles, extra oil consumption, smoke, etc. After a particularly prolonged inactivity (over 2 years) and if the engine is stored in an unsuitable environment all rubber parts must be checked, specially the sealing ones.*



*Caution! The warranty does not cover defects caused by prolonged storage.*

**TROUBLESHOOTING**

<b>CAUSE</b>	<b>DEFECT</b>	Air filter clogged	Breather pipe bent	Engine run-in	Inadequate fuel	Air in the fuel	Diesel oil filter or pipes clogged	Fuel tank empty	Head and cylinder fins clogged	Excessive load	Tank cap breather clogged	Too much oil in the sump	Cold engine
The engine does not start					●	●		●					
The engine starts and then stops	●					●	●				●		
Low performance	●						●						
Blue smoke												●	
Black smoke										●			
Engine knocks					●								
Oil over-consumption												●	
Oil leakage		●											
Oil leakage from mutter				●									
The engine is too hot								●	●				
The engine misfires					●	●					●		●
Revolution do not increase					●	●					●		

The table supplies indications regarding the main causes of defects that the operator can easily solve.



*In case of more serious problems, please contact Ruggnerini Service Centre experts.*

*Alternatore interno • Internal built-in alternator  
Alternateur interieur • Alternador interno • Innerer generator*

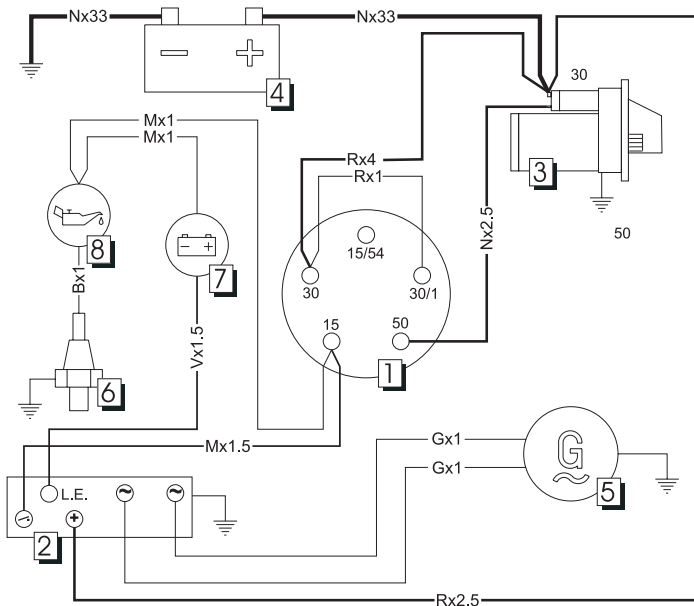

**CAVI  
CABLES  
CÂBLES  
CABLES  
KABEL**

*Colore x Sezione (mm<sup>2</sup>)  
Color x Section (mm<sup>2</sup>)  
Couleur x Section (mm<sup>2</sup>)  
Color x Sección (mm<sup>2</sup>)  
Farbe x Querschnitt (mm<sup>2</sup>)*

*Colore  
Color  
Couleur  
Color  
Farbe*

**M** Marrone  
Brown  
Marron  
Marrón  
Braun

**N** Nero  
Black  
Noir  
Negro  
Schwarz

**A** Bianco  
White  
Blanc  
Blanco  
Weiß

**V** Verde  
Green  
Vert  
Verde  
Grün

**R** Rosso  
Red  
Rouge  
Rojo  
Rot

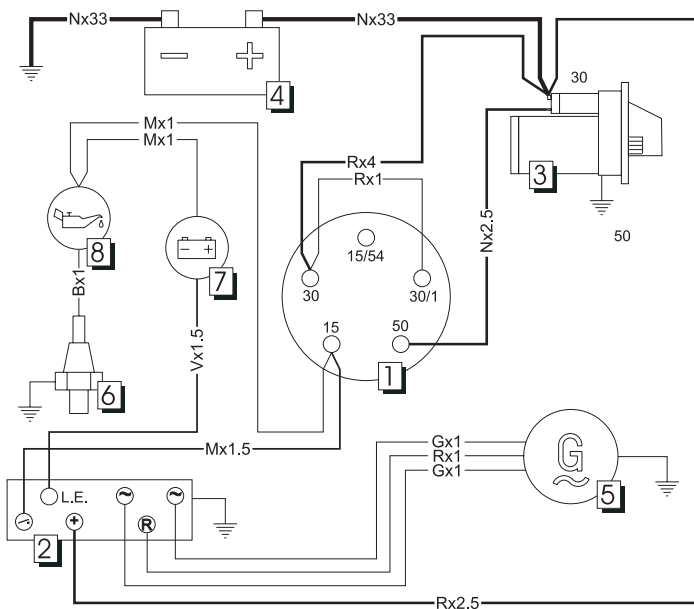

*Alternatore esterno • External alternator  
Alternateur exterieur • Alternador externo • Äusserer generator*



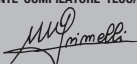

## RUGGERINI MOTORI

Via Cav. del Lavoro A. Lombardini, 2 - 42100 REGGIO EMILIA (ITALY)  
Tel. 0522 3891 - Fax 0522 389433/465 - [www.ruggerini.it](http://www.ruggerini.it)

ENTE COMPILATORE TECO/ATL 	COD. LIBRO 1-497R-047	REVISIONE 00	VISTO 
	MODELLO N° 00497R0470	DATA 10.10.2003	
	DATA EMISSIONE 10-10-03		

