

**RECORD POWER**  
ESTABLISHED 1909®

## Original Instruction Manual

# PT107 10" x 7" Heavy Duty Planer Thicknesser

Version 3.0  
January 2013



To register this product please visit  
**[www.recordpower.info](http://www.recordpower.info)**

It is important to register your product as soon as possible in order to receive efficient after sales support and be entitled to the full **5 year guarantee**. Your statutory rights are not affected.  
Please see back cover for contact details.



Always wear safety glasses when using woodworking equipment.



Always read the instructions provided before using woodworking equipment.

### Important

For your safety read instructions carefully before assembling or using this product.

Save this manual for future reference.

# Contents

## **Terms & Conditions Of Usage**

Explanation of Symbols

General Health & Safety Guidance

Additional Safety Instructions For Planer Thicknessers

Record Power Guarantee

## **User Manual**

**1** Machine Specifications

**2** Getting to Know Your Machine

**3** Electrical System

**4** Assembly

**5** Operation

**6** Maintenance

**7** Dust Extraction

**8** Electrical Connection & Wiring Diagram

**9** Troubleshooting

**10** Parts List & Diagrams

EU Certificate of Conformity

# Explanation of Symbols

**THE SYMBOLS AND THEIR MEANINGS SHOWN BELOW MAY BE USED THROUGHOUT THIS MANUAL. PLEASE ENSURE THAT YOU TAKE THE APPROPRIATE ACTION WHEREVER THE WARNINGS ARE USED.**

## **Mandatory Instructions**



Read and fully understand the instruction manual before attempting to use the machine.



Indicates an instruction that requires particular attention



Wear protective eyewear



Use respiratory protective equipment



Use hearing protection



Use suitable protective footwear



Use protective work gloves

## **Warning**



Indicates a risk of severe personal injury or damage to the machine



Indicates a risk of severe personal injury from electrical shock



Risk of personal injury from lifting of heavy items



Indicates a risk of severe personal injury from airborne objects



Risk of fire

# General Health & Safety Guidance

**Ensure that you carefully read and fully understand the instructions in this manual before assembly, installation and use of this product. Keep these instructions in a safe place for future reference.**

**WARNING:** for your own safety, do not attempt to operate this machine until it is completely assembled and installed according to these instructions.

**WARNING:** When using any machine, basic safety precautions should always be followed to reduce the risk of fire, electric shock and personal injury.

## Safe Operation

### 1. Use Personal Protective Equipment (PPE)

- The operation of any machine can result in foreign objects being thrown into your eyes, which can result in severe eye damage. Protective eyewear or other suitable eye protection or face shield should be used at all times. Everyday spectacles only have impact resistant lenses. They are not protective eyewear and do not give additional lateral protection.
- Use respiratory protective equipment (dust mask etc.) if the machining operation creates dust. Exposure to high levels of dust created by machining hardwoods, softwoods and man made composite boards can result in serious health problems. Some imported hardwoods give off highly irritating dust, which can cause a burning sensation. The use of respiratory protective equipment should not be seen as an alternative to controlling the risk of exposure at source by using adequate dust extraction equipment.
- The use of ear plugs or ear defenders is recommended when the machine is in use, particularly if the noise level exceeds 85 dB.
- Wear suitable protective gloves when handling cutting tools or blades. Gloves should NOT be worn when using the machine as they can be caught in moving parts of the machine.
- Non-slip safety footwear is recommended when using the machine and handling large work pieces.

### 2. Dress appropriately

- Do not wear loose clothing, neckties or jewellery; they can be caught in moving parts of the machine.
- Roll up long sleeves above the elbow.
- Wear protective hair covering to contain long hair.

### 3. Safety warnings

- Find and read any warning labels on the machine.
- It is important that any labels bearing health and safety warnings are not removed, defaced or covered. Replacement labels can be obtained by contacting our Customer Service Department.

### 4. Familiarise yourself with the machine

- If you are not thoroughly familiar with the operation of this machine, obtain advice from your supervisor, instructor, or other qualified person or contact your retailer for information on training courses. Do not use this machine until adequate training has been undertaken.

### 5. Take care when moving or positioning the machine

- Some machines can be very heavy. Ensure the floor of the area in which the machine is to be used is capable of supporting the machine.
- The machine and its various components can be heavy. Always adopt a safe lifting technique and seek assistance when lifting heavy components. In some cases it may be necessary to use mechanical handling equipment to position the machine within the work area.
- Some machines have optional wheel kits available to allow them to be manoeuvred around the workshop as required. Care should be taken to install these according to the instructions provided.
- Due to the nature of the design of some machines the centre of gravity will be high making them unstable when moved. Extreme care should be taken when moving any machine.

### 6. The machine should be level and stable at all times

- When using a leg stand or cabinet base that is designed to be fitted to the machine, always ensure that it is securely fastened to the machine using the fixings provided.

- If the machine is suitable to be used on a workbench, ensure that the workbench is well constructed and capable of withstanding the weight of the machine. The machine should always be securely fastened to the workbench with appropriate fixings.
- Where possible, floor standing machines should always be secured to the floor with fixings appropriate to the structure of the floor.
- The floor surface should be sound and level. All of the feet of the machine should make contact with the floor surface. If they do not, either re-locate the machine to a more suitable position or use packing shims between the feet and the floor surface to ensure the machine is stable.

### 7. Remove adjusting keys and wrenches

- Ensure that all adjusting wrenches and keys are removed before switching the machine 'ON'. There is a risk of severe personal injury or damage to the machine from airborne objects.

### 8. Before switching the machine 'ON'

- Clear the machine table of all objects (tools, scrap pieces etc.)
- Make sure there is no debris between the work piece and the table / work support.
- Ensure that the work piece is not pressed against, or touching the saw blade or cutting tool.
- Check all clamps, work holding devices and fences to ensure that they are secure and cannot move during machining operations.
- Plan the way that you will hold and feed the work piece for the entire machining operation.

### 9. Whilst machining

- Before starting work, watch the machine while it runs. If it makes an unfamiliar noise or vibrates excessively, switch the machine 'OFF' immediately and disconnect it from the power supply. Do not restart until finding and correcting the source of the problem.

### 10. Keep the work area clear

- Working clearances can be thought of as the distances between machines and obstacles that allow safe operation of every machine without limitation. Consider existing and anticipated machine needs, size of material to be processed through each machine and space for auxiliary stands and/or work tables. Also consider the relative position of each machine to one another for efficient material handling. Be sure to allow yourself sufficient room to safely operate your machines in any foreseeable operation.
- Cluttered work areas and benches create the risk of accidents. Keep benches clear and tidy away tools that are not in use.
- Ensure that the floor area is kept clean and clear of any dust and debris that may create trip or slip hazards.

### 11. Consider the work area environment

- Do not expose the machine to rain or damp conditions.
- Keep the work area well lit and ensure that there is artificial lighting available when there is insufficient natural light to effectively light the work area. Lighting should be bright enough to eliminate shadow and prevent eye strain.
- Do not use the machine in explosive environments eg. in the presence of flammable liquids, gases or dust.
- The presence of high levels of dust created by machining wood can present a risk of fire or explosion. Always use dust extraction equipment to minimise the risk.

### 12. Keep other persons away (and pets)

- The machine is designed to be used by one person only.
- Do not let persons, especially children, touch the machine or extension cable (if used) and keep visitors away from the work area.
- Never leave the machine running unattended. Turn the power supply off and do not leave the machine unattended until it comes to a complete stop.
- If the work area is to be left unattended, all machinery should be switched 'OFF' and isolated from the mains power supply.

### 13. Store machines safely when not in use

- When not in use, machines should be stored in a dry place, out of reach

# General Health & Safety Guidance cont.

of children. Do not allow persons unfamiliar with these instructions or with the machine to operate it.

## 14. Do not overreach

- Choose a working position that allows your body to remain balanced and feed the work piece in to the machine without overreaching.
- Keep proper footing and balance at all times.

## 15. Electrical supply

- Electrical circuits should be dedicated to each machine or large enough to handle combined motor amp loads. Power outlets should be located near each machine so that power or extension cables are not obstructing high-traffic areas. Observe local electrical guidelines for proper installation of new lighting, power outlets, or circuits.
- The machine must be connected to an earthed power supply.
- The power supply must be equipped with a circuit breaker that provides short circuit, overload and earth leakage protection.
- The voltage of the machine must correspond to the voltage of the mains power supply.
- The mains plug fitted to the machine should always match the power outlet. Do not modify the plug in any way. If a replacement plug is required it should be fitted by a competent person and of the correct type and rating for the machine.
- If you are unsure about any electrical connections always consult a qualified electrician.

## 16. Avoid unintentional starting of the machine

- Most machines are fitted with a no-volt release (NVR) switch to prevent unintentional starting. If in doubt always ensure the machine switch is in the 'OFF' position before connecting it to the power supply. This means the machine will not automatically start up after a power cut or switching on of the power supply, unless you first reset the start switch.

## 17. Outdoor use

- Your machine should not be used outdoors.

## 18. Extension cables

- Whenever possible, the use of extension cables is not recommended. If the use of an extension cable is unavoidable, then it should have a minimum core cross section of 2.5mm<sup>2</sup> and limited to a maximum length of 3 metres.
- Extension cables should be routed away from the direct working area to prevent a trip hazard.

## 19. Guard against electric shock

- Avoid body contact with earthed or grounded surfaces such as pipes and radiators. There is an increased risk of electric shock if your body is earthed or grounded.

## 20. Always work within the machine's intended capacities

- Operator safety and machine performance are seriously adversely affected if attempts to make the machine perform beyond its limits are made.

## 21. Do not abuse the power cable

- Never pull the power cable to disconnect it from the power socket. Always use the plug.
- Keep the power cable away from heat, oil and sharp edges.
- Do not use the power cable for carrying or moving the machine.

## 22. Secure the work piece

- Ensure that the work piece is securely held before starting to machine it.
- When working within 300 mm of the machining area, always use a push stick to feed the work piece in to the blade or cutting tool. The push stick should have a minimum length of 400 mm. If the push stick becomes damaged, replace it immediately.
- Use extra supports (roller support stands etc.) for any work pieces large enough to tip when not held down to the table top.
- Do not use another person as a substitute for a table extension, or as additional support for a work piece that is longer or wider than the basic table, or to help feed, support, or pull the work piece.
- Do not attempt to machine more than one work piece at a time.

- When feeding the work piece towards the blade or cutting tool never position your hands in direct line of the cutting path. Avoid awkward operations and hand positions where a sudden slip could cause your hand or fingers to move into the machining area.

## 23. Stay alert

- Safety is a combination of operator common sense and alertness at all times when the machine is being used.
- Use all machines with extreme care and do not use the machine when you are tired or under the influence of drugs, alcohol or medication.

## 24. Use the correct tool for the job

- Do not use the machine for any purpose other than which it was designed.
- When selecting replacement cutting tools and blades, always ensure that they are designed to cut the material that you intend to use them for. If in any doubt seek further advice from the manufacturer.

## 25. Connect dust extraction equipment

- Always use dust extraction equipment. The dust extractor should be of suitable size and capacity for the machine that it is connected to and have a filtration level appropriate to the type of waste being collected. Refer to the relevant section of the manual for details of the specific dust extraction requirements for this machine.
- The dust extractor should be switched 'ON' before starting the machine that it is connected to. The dust extractor should be left running for 30 seconds after the last machining operation is complete in order to clear any residual waste from the machine.

## 26. Ensure that the machine is correctly guarded

- Never use the machine if any of the standard safety guards and equipment are removed or damaged.
- Some machines incorporate safety interlocks to prevent the machine from being used without the guards in place. Never attempt to bypass or modify the interlocks to allow the machine to be used without the guards in place.

## 27. Maintain your machine with care

- This manual gives clear instructions on installation, set up and operation of the machine and also details any routine and preventative maintenance that should be performed periodically by the user.
  - Remember always to switch off and unplug the machine from the power supply before carrying out any setting up or maintenance operations.
  - Follow any instructions for the maintenance of accessories and consumables.
  - Do not use compressed air to clean the machine. Always use a brush to dislodge dust in places that are awkward to reach and a dust extractor to collect the waste.
  - Inspect electric cables periodically and, if damaged, have them replaced by an authorised service facility or qualified electrician.
  - Inspect extension cables (if used) periodically and replace if damaged.
- ## 28. Keep cutting tools sharp and clean
- Correctly maintained cutting tools are easier to control and less likely to bind.
  - Cutting tools and blades can become hot during use. Take extreme care when handling them and always allow them to cool before changing, adjusting or sharpening them.

## 29. Disconnect the machine from the power supply

- When not in use, before servicing, changing blades etc. always disconnect the machine from the power supply.

## 30. Check for damaged parts

- Before each use of the machine, it should be carefully checked to determine that it will operate properly and perform its intended function.
- Check for alignment of moving parts, binding of moving parts, breakage of parts and any other conditions that may affect the operation of the machine.
- A guard or other part that is damaged should be properly repaired or replaced by a qualified person unless otherwise indicated in this

# General Health & Safety Guidance cont.

instruction manual.

- Do not use the machine if the switch does not turn the machine 'ON' and 'OFF'.
- Have defective switches replaced by a qualified person.

## **31. Warning!**

- The use of any accessory or attachment, other than those recommended in this instruction manual, or recommended by our Company may present a risk of personal injury or damage to the machine and invalidation of the warranty.

## **32. Have your machine repaired by a qualified person**

- This machine complies with the relevant safety rules and standards appropriate to its type when used in accordance with these instructions and with all of the standard safety guards and equipment in place. Only qualified persons using original spare parts should carry out repairs. Failure to do this may result in considerable danger to the user and invalidation of warranty.

## **33. Caution! Motor may become hot during use**

- It is normal for motors on some machines to become hot to the touch during use. Avoid touching the motor directly when in use.

# Additional Health & Safety for Planer Thicknessers

**WARNING: FOR YOUR OWN SAFETY, DO NOT ATTEMPT TO OPERATE YOUR PLANER THICKNESSER UNTIL IT IS COMPLETELY ASSEMBLED AND INSTALLED ACCORDING TO THESE INSTRUCTIONS**

## Safe Operation

### 1. The planer thicknesser should be level and stable at all times

- If using an optional wheel kit to position the machine within your workshop, never attempt to move the machine with the surface tables in the raised position as this will raise the centre of gravity and make the machine unstable.

### 2. Familiarise yourself with the machine

- Machining operations using planer thicknessers have a history of serious accidents. Most accidents resulted from contact with the cutter block when surface planing due to the guard being incorrectly adjusted or missing from the machine.
- The machine is designed for planing hard and soft woods. It is not designed for planing any other material.
- Do not attempt to perform rebating, moulding, cutting tenons and recessing. The machine is designed to prevent these operations from being performed. Do not modify the machine in order to attempt any of these operations.

### 3. Before switching the machine 'ON':

- Set and secure safety guards in position before operating the machine. Adjust the guards to suit the size of work piece. Full details of the correct setting of the guards is included within the manual.
- Before starting work, watch the planer while it runs. If it makes an unfamiliar noise or vibrates excessively, switch the machine 'OFF' immediately and disconnect it from the power supply. Do not restart until finding and correcting the problem.
- Regularly check that the blades and lock bars are locked tight in the cutter block.
- Regularly check the anti-kickback fingers of the thicknesser for proper operation.
- Make sure there are no nails, screws or foreign objects in the part of the work piece to be planed.
- Make sure there is no debris between the work piece and the table or fence.
- Check that the fence, guards and work holding devices are secure and that the fixings for them are fully tightened.
- Clear the planing tables of all objects (tools, scrap pieces etc.).
- Plan the way you will hold and feed the work piece from start to finish.

### 4. Whilst planing:

- Never remove any of the safety guards. Keep guards operational at all times.
- Use extra caution with large, very small or irregularly shaped work pieces.
- Use extra supports (roller support stands etc) for any work pieces large enough to tip when not held down to the table top.
- Do not use another person as a substitute for a table extension, or as additional support for a work piece that is longer than the basic planer table, or to help feed, support, or pull the work piece.
- When planing irregularly shaped work pieces, or chamfering with the fence at 45°, plan your work support so it will not slip and be pulled from your hands.
- When planing short work pieces an additional push block should be used. Never attempt to plane a work piece that is too small to hold by hand.
- Avoid awkward operations and hand positions where a sudden slip could cause fingers or hands to move into the cutter block.
- Never make planing cuts deeper than 3mm / 1/8".
- Plane only one work piece at a time.
- Keep your face and body to one side, out of line with a possible kick back.

- If the work piece binds when thicknessing the machine may stall. If this happens, switch the machine 'OFF' immediately and follow the instructions detailed in the manual for safely removing the work piece. Do not attempt to free the work piece whilst the machine is running.

### 5. Maintenance:

- Regularly check that all safety guards are present and in full working order.
- Regularly check that the bridge guard moves freely, both horizontally and vertically.
- Keep the guards clean and free from waste material and deposits of resin.
- Regularly clean the planer table and thicknesser bed and apply a suitable lubricant (silicone wax or spray to help the work piece slide easily).
- The planer knives should be sharpened regularly to reduce the risk of snatching and kick back.
- Do not exceed maximum allowable blade projection over cutter block of 1.0mm/ 0.040 inch +10%.

6. This machine falls under the scope of the 'Health & Safety at Work etc. Act 1974', and the 'Provision & Use of Work Equipment Regulations 1998'. In addition the elimination or control of risks from wood dust is included in the above regulations and the 'Control of Substances Hazardous to Health (COSHH) Regulations 2002'. We recommend that you study and follow these regulations.

Further guidance is available from The Health & Safety Executive and their website [www.hse.gov.uk](http://www.hse.gov.uk).



# Record Power Guarantee

“**Products**” means the Products sold by Record Power subject to these terms and conditions;

“**Record Power**” is Record Power Limited, whose company registration number is 4804158 and registered office address is Unit B, Ireland Industrial Estate, Adelphi Way, Staveley, Chesterfield, S43 3LS and sells through a network of Authorised Dealers;

“**Authorised Distributor**” is the nominated importer for your region who will generally sell through a network of Authorised Dealers. Details of Authorised Distributors for specific countries can be found in the Product manual or at [www.recordpower.info](http://www.recordpower.info);

“**Authorised Dealer**” is a retailer or business authorised to sell Record Power Products to end users.

## 1 Guarantee

- 1.1 Record Power guarantees that for a period of 5 years from the date of purchase the components of qualifying Products (see clauses 1.2.1 to 1.2.9) will be free from defects caused by faulty construction or manufacture.
- 1.2 During this period Record Power, its Authorised Distributor or Authorised Dealer will repair or replace free of charge any parts which are proved to be faulty in accordance with paragraphs 1.1 above provided that:
  - 1.2.1 you follow the claims procedure set out in clause 2 below;
  - 1.2.2 Record Power, our Authorised Distributor or Authorised Dealer are given a reasonable opportunity after receiving notice of the claim to examine the Product;
  - 1.2.3 if asked to do so by Record Power, its Authorised Distributor or Authorised Dealer, you return the Product, at your own cost, to Record Power’s premises or other approved premises such as those of the Authorised Distributor or supplying Authorised Dealer, for the examination to take place;
  - 1.2.4 the fault in question is not caused by industrial use, accidental damage, fair wear and tear, wilful damage, neglect, incorrect electrical connection, abnormal working conditions, failure to follow our instructions, misuse, or alteration or repair of the Product without our approval;
  - 1.2.5 the Product has been used in a domestic environment only;
  - 1.2.6 the fault does not relate to consumable Products such as blades, bearings, drive belts or other wearing parts which can reasonably be expected to wear at different rates depending on usage (for full details contact Record Power or your local Authorised Distributor);
  - 1.2.7 the Product has not been used for hire purposes, by you or by a previous owner;
  - 1.2.8 the Product has been purchased by you as the guarantee is not transferable from a private sale.
  - 1.2.9 where the Product has been purchased from a retailer, the 5 year guarantee is transferable and begins on the date of the first purchase of the Product and in the event of a claim under this guarantee proof of the original purchase date will be required to validate the warranty period.

## 2 Claims Procedure

- 2.1 In the first instance please contact the Authorised Dealer who supplied the Product to you. In our experience many initial problems with machines that are thought to be due to faulty parts are actually solved by correct setting up or adjustment of the machines. A good Authorised Dealer should be able to resolve the majority of these issues much more quickly than processing a claim under the guarantee.
- 2.2 Any damage to the Product resulting in a potential claim under the guarantee must be reported to the Authorised Dealer from which it was purchased within 48 hours of receipt.
- 2.3 If the Authorised Dealer who supplied the Product to you has been unable to satisfy your query, any claim made under this Guarantee should be made directly to Record Power or its Authorised Distributor (for details of the Authorised Distributor in your country please see your Product manual or check [www.recordpower.info](http://www.recordpower.info) for details). The claim itself should be made in a letter setting out the date and place of purchase, and giving a brief explanation of the problem which has led to the claim. This letter should then be sent with proof of the purchase date (preferably a receipt) to Record Power or its Authorised Distributor. If you include a phone number or email address this will help to speed up your claim.
- 2.4 Please note that it is essential that the letter of claim reaches Record Power or its Authorised Distributor on the last day of this Guarantee at the latest. Late claims will not be considered.

## 3 Limitation of Liability

- 3.1 We only supply Products for domestic and private use. You agree not to use the Product for any commercial, business or re-sale purposes and we have no liability to you for any loss of profit, loss of business, business interruption or loss of business opportunity.
- 3.2 This Guarantee does not confer any rights other than those expressly set out above and does not cover any claims for consequential loss or damage. This Guarantee is offered as an extra benefit and does not affect your statutory rights as a consumer.

## 4 Notice

This Guarantee applies to all Products purchased from an Authorised Dealer of Record Power within the United Kingdom of Great Britain and Northern Ireland. Terms of Guarantee may vary in other countries – please check with the Authorised Distributor in your country (details of the Authorised Distributor for your country can be found in the manual or at [www.recordpower.info](http://www.recordpower.info)).



# 1. Machine Specification

**CUTTER BLOCK DIAMETER:** 75 mm

**NUMBER OF CUTTERS:** 3

**BLADE SIZE:** 260 x 18.5 x 3 mm

**CUTTER BLOCK SPEED:** 4000 rpm

**PLANING TABLE SIZE:** 1100 x 265 mm

**MAXIMUM PLANING WIDTH:** 260 mm

**THICKENING TABLE SIZE:** 600 x 258 mm

**MAXIMUM THICKENING WIDTH:** 258 mm

**MAXIMUM CHIP REMOVAL:** 3 mm (Planing)

**MAXIMUM CHIP REMOVAL:** 2 mm (Thickening)

**MAXIMUM THICKENING HEIGHT:** 190 mm

**WOOD FEED RATE:** 5m/min

**FENCE SIZE:** 1065 x 130 mm

**FENCE PIVOT:** 90°- 45°

**DUST PORT DIAMETER:** 100 mm

**WEIGHT:** 162 kg

**NOISE LEVEL:** Sound power level 85 dB(A) / 106 dB(A) Unloaded / loaded  
Sound pressure level 83 dB(A) / 100 dB(A) Unloaded / loaded

**MOTOR:** 230 V / 50 Hz / 3 hp / 2200 W

**FULL LOAD CURRENT:** 9.7 A

# 2. Getting to Know your Machine

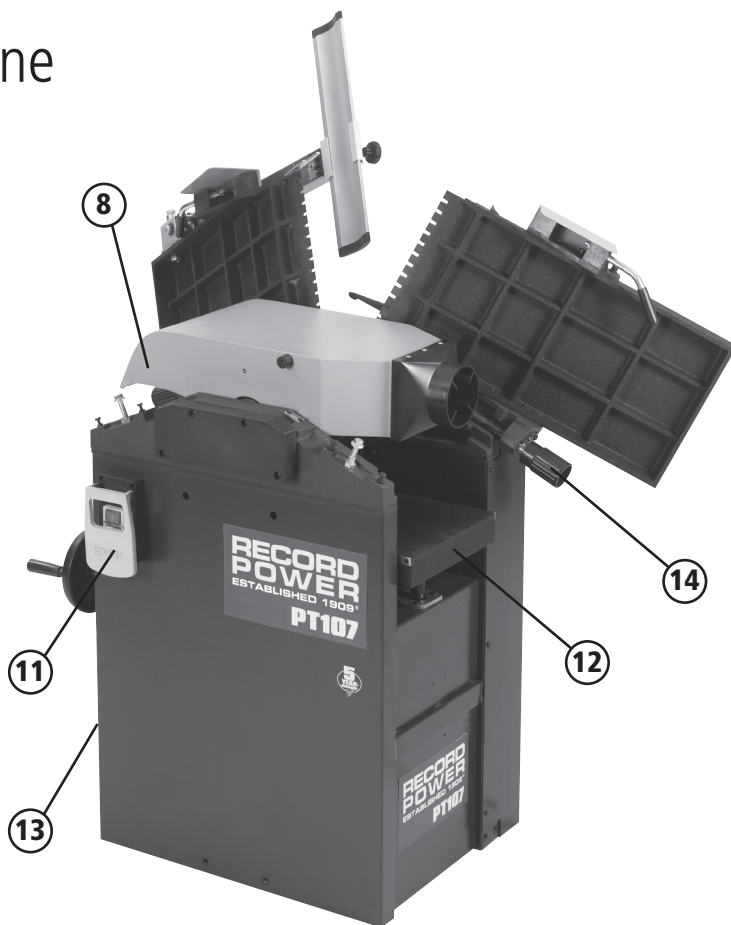
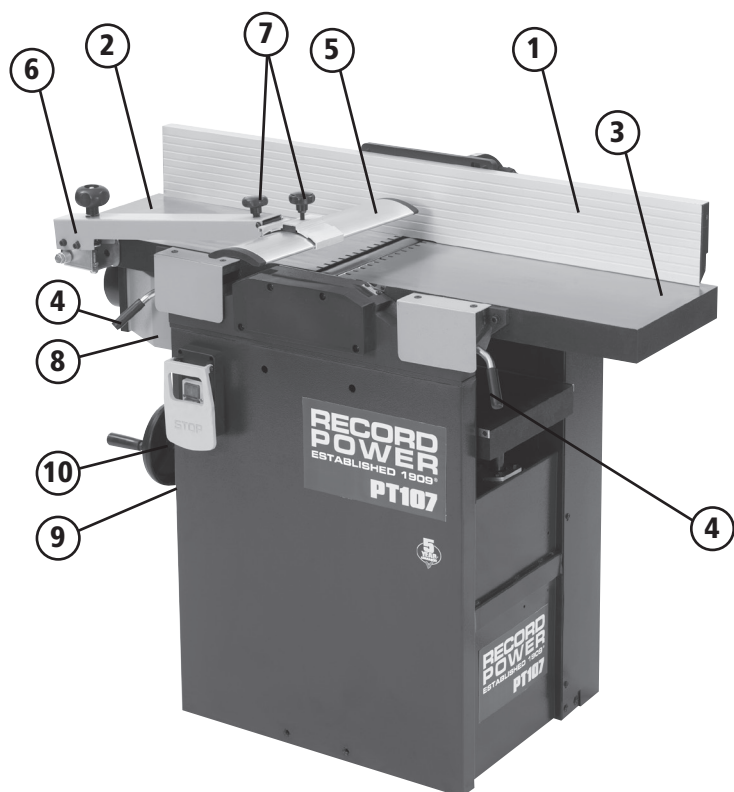

- 1 Fence
- 2 Outfeed table
- 3 Infeed table
- 4 Table lock
- 5 Protective guard
- 6 Bridge guard arm
- 7 Adjustable knob, guard

- 8 Dust hood
- 9 Thickener table lock lever (not visible)
- 10 Thickening height hand wheel
- 11 Power switch
- 12 Thickener table
- 13 Thickener feed clutch (not visible)
- 14 Planer table, adjust handle

# 3. Electrical System

## Power Switch

Switch the planer ON at the small green button (Fig 3.1 - A).

Switch the planer OFF at the big red button (Fig 3.1 - B).

The red button has emergency-stop function. The large yellow flap (B) can be used to stop the machine.

## Limit Switch

Your machine is equipped with 2 safety limit switches.

The planer cutter block can only run when

-the planer tables are closed (Fig 3.2 - A)

or

-the extractor hood is positioned over the cutterblock when the tables are raised for thicknessing operations. (Fig 3.2 - B)

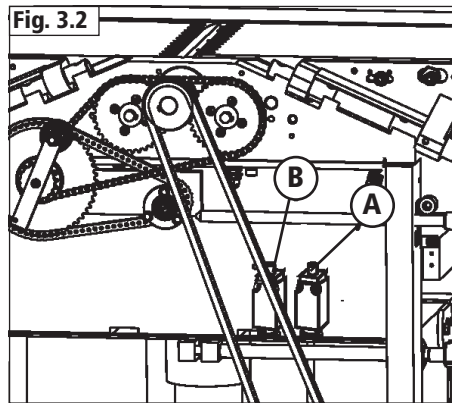
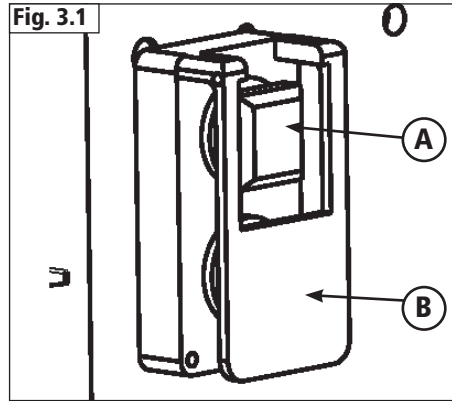

# 4. Assembly

## Unpacking

The machine is shipped from the manufacturer in a carefully packed crate. If you discover the machine is damaged after you have signed for delivery, please call Customer Service immediately for advice. When you are completely satisfied with the condition of your shipment, check all parts are present.

The planer thicknesser is a heavy machine. DO NOT over-exert yourself while unpacking or moving your machine. You will need assistance and power equipment to move the machine. Serious personal injury may occur if safe moving methods are not followed.



**Warning: Never lift the machine by the planer tables when unloading. Belt and chains may only be attached to the stand.**

Ensure that lifting gear used has an adequate capacity and the load is secured against lateral slippage!

Unloading can be performed using a forklift, pallet jack or crane.

We recommend rolling the machine from the pallet via the optional wheel kit, Fig 4.2. You must first bolt this to the machine.



**Warning: Some metal parts may have sharp edges on them. Please examine the edges of all metal parts before handling them. Failure to do so could result in injury.**

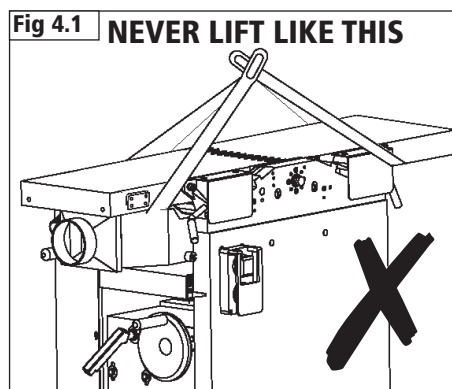

# 4. Assembly

## Assembling the Optional Wheelkit

Items provided in the PT107 optional wheelkit (**Fig. 4.3**):

- A** Lifting Bracket
- B** Wheels
- C** Hex nuts and bolts
- D** Jockey bar with wheels

Simply attach the wheels (**Fig. 4.3, B**) to each corner at the back of the machine as shown in **Fig. 4.4**.

These wheels are secured into place by two hex nuts being placed through the pilot holes in the machine body and held in place with nuts.

The lifting bar is held in place at the front of the machine using a similar process using two hex nuts being placed through the pilot holes in the machine body and secured in place by two nuts, **Fig. 4.5**.

When the wheel kit is not in use, the wheels fitted to the main body of the machine can be raised by unscrewing the adjusting screw (**Fig 4.4, A**) so that they are clear of the surface of the floor.

The wheels should be lowered again before attempting to use the wheel kit.



Never attempt to move the machine with wheel kit whilst the planer tables are in the raised position. The centre of gravity will be high making the machine unstable. Always ensure that the tables are in the closed position before attempting to move the machine.

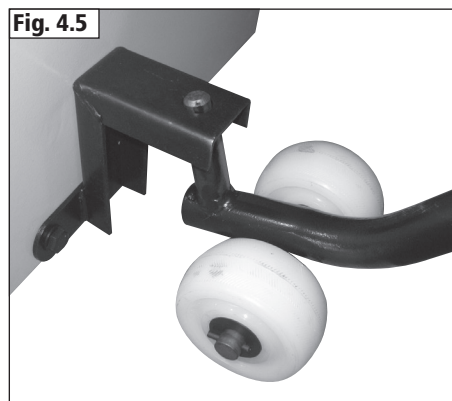
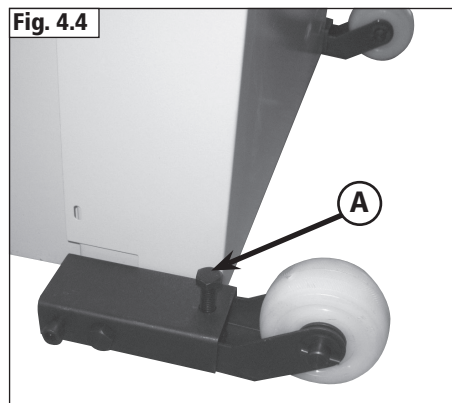
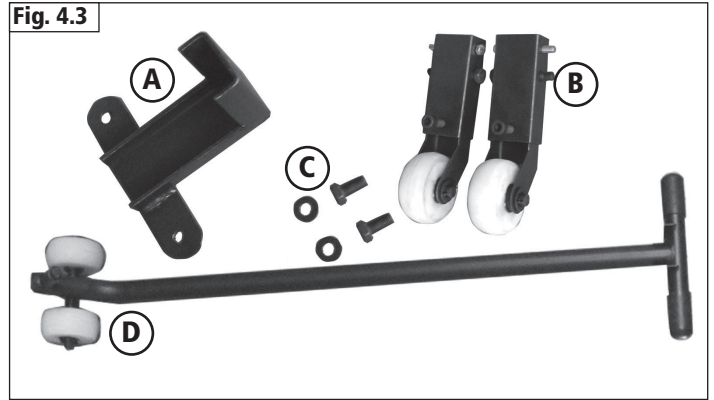

# 4. Assembly

## Clean Up

The unpainted surfaces are coated with a waxy oil to protect them from corrosion during shipment. Remove this protective coating with a solvent cleaner or citrus based greaser. To clean thoroughly, some part may need to be removed. For optimum performance from your machine, make sure you clean all moving parts or sliding contact surfaces that are coated. Avoid chlorine-based solvents as they may damage painted surfaces should they come in contact.



**Warning: Do not use gasoline or other petroleum-based solvents to clean with. They have low flash points which make them extremely flammable. A risk of explosion and burning exists if these products are used.**



**Warning: Do not smoke while using solvents. A risk of explosion or fire exists and may result in serious personal injury.**

## Contents of Carton

After all the parts have been removed from the carton, you should have:

- PT107 main unit
- Bridge guard assembly
- Fence assembly
- Push stick
- Cover plate for the end of the cutter block
- Emergency stop cover for switch
- Cutter-block setting gauge
- 3mm allen key
- 8 & 10mm open end spanner

## Fitting the Bridge Guard

1. Insert the M10x100 hex head screw with spacer (A - **Fig 4.3**) to mount the bridge guard to out-feed table (the washer and lock nut should be fitted under the out-feed table).
2. Sliding the protective bridge guard (B - **Fig 4.3**) into bridge guard support bracket (C - **Fig 4.3**).
3. Then adjust the three star knob screws to keep the bridge guard in position.
4. Fit the cover plate (D - **Fig 4.3**) (under protective guard plate) onto the machine frame with 4-pan head screws M6 x 30.

## Fitting the Fence (if Needed)

1. Pull the protective guard (B - **Fig 4.3**) out as far as possible
2. Place the fence assembly (A - **Fig 4.4**) onto the planer table and slide the fence carrier into the bracket fitted to the machine.
3. Tighten the fence in position with the star knob (B - **Fig 4.4**).

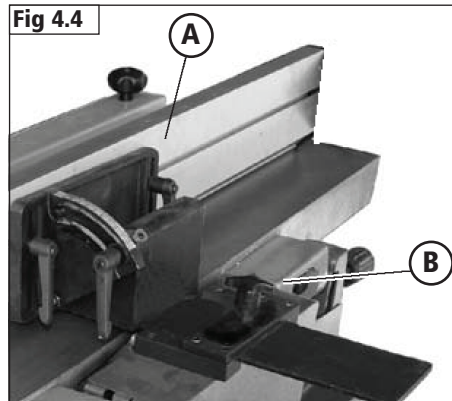
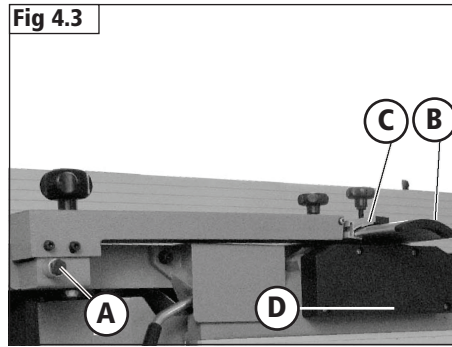

? Picture

# 5. Operation

## General information

### Safety instructions

Before every use, check:

- All required guards are properly installed.
- All clamping screws of the blade holders are tight (minimum tightening torque: 15 Nm).
- That you are always using sharp planer blades (minimizes the risk of kickback).
- That the individual anti kickback guards can move freely and fall back into their initial position after being lifted. (applies only to thicknesser function)
- Use auxiliary devices when working short and narrow pieces (e.g. push stick or safety feed blocks).

### Remaining risks

The following risks remain when working with the planer thicknesser despite observing the appropriate protective measures:

- Danger of injury when changing blade.
- Observing of injury due to contact with the rotating planer cutterblock.
- Danger of injury due to ejected workpieces.
- Danger of injury due to workpiece kickback.
- Hearing danger due to high noise levels.
- Health risks due to dust emission during work especially when processing beech and oak.

### Working techniques

Permitted working techniques.

All uses deviating from those described below are considered improper uses and are therefore not permitted.

- Planing the wide side of a workpieces.
- Planing the narrow side of a workpieces.
- Bevelling the edges of a workpieces.

### Prohibited Working Techniques

The following work techniques are prohibited on the machine.

- Down-cut jointing (direction of arbor rotation same as feed direction).
- Insertion cuts (workpiece is not worked along its entire length).
- Planing of excessively warped timber.
- Thickness planing of multiple workpieces of different thicknesses.

### Planer Bridge Guard

The planer bridge guard consists of the protective guard plate (A - Fig. 5.1), the planer bridge guard arm (B - Fig. 5.1), and support bracket (C - Fig. 5.1).

The height and width of the protective rail is continuously adjustable.

Height adjustment (arm tilt): set Star knob screw (D - Fig. 5.1).

Width adjustment: Star- knob screw (E - Fig. 5.1).

Star - knob screw (F - Fig. 5.1) is adjusted to keep the guard level.

### Setting the Planer Table

#### The Feed Table Adjustment

Open table lock (A - Fig 5.2). Turn adjusting handle (B - Fig 5.2) until you can see the desired value on scale (C - Fig 5.2) (maximum 4 mm) Re-tighten the table lock securely.

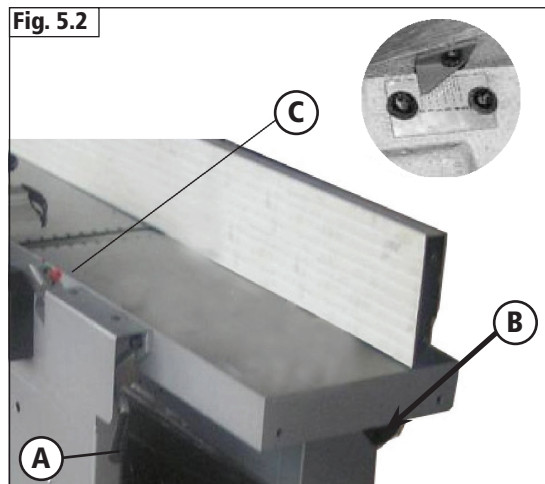
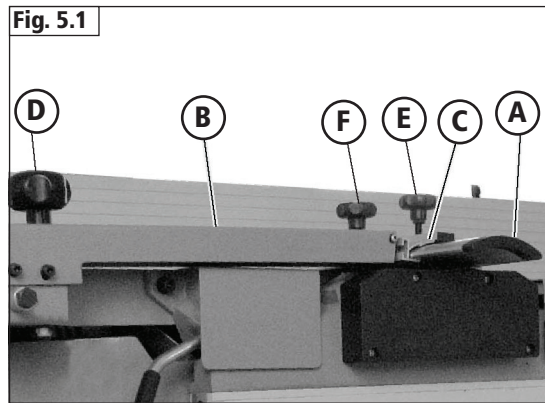



# 5. Operation

## Out-feed Table Adjustment



**Please note:** The height of out-feed table is factory set. It should only require adjustment in cases where other normal adjustments to the planer knives have not rectified any alignment issues.



**Please note:** Before carrying out any of the adjustments below, ensure that the machine is switched off and that the power cord is disconnected from the mains supply.

After several hours running, the outfeed table may need adjustment.

1. Loosen two hex nuts in the adjusting handle (A - **Fig. 5.3**).
2. Open table lock (B - **Fig. 5.3**) and turn adjusting handle, but do not raise the table.
3. Place a straight edge on the out-feed table, and adjust the table so that it is 0.1mm lower than the blade at its highest point.
4. Then re-tighten the table lock (B - **Fig. 5.3**) securely, re-tighten 2- hex nuts in handle (A - **Fig. 5.3**).

### Aligning the Out-Feed Table

1. Remove the belt guard so you can rotate the cutter block safely.
2. Rotate the cutter block so that one of the knives is at top dead centre.

**Note:** A knife is at top dead centre when it is at its highest point during the rotation. See **Fig. 5.4** for illustration of a knife at top dead centre.

3. Place a straightedge across the out-feed table, so the end of the straightedge is directly over the knife (**Fig. 5.5**).
4. If the out-feed table is set correctly, the straightedge will lay across the table and barely touch the knife when it is at top dead centre (see illustration in **Fig. 5.5**). Verify that the out-feed table height reflects this condition.
5. If the out-feed table needs to be adjusted, release the Out-feed table lock and adjust the height by rotating the Hand-wheel that is located below the table.
6. When you have the out-feed table properly adjusted, lock the table height in place.

### Adjusting the In-Feed Table

1. Make sure the out-feed table is adjusted as previously described.
2. Place a straightedge across the out-feed table and the infeed table.

**Note:** The straight edge used must be long enough to span the full length of both tables.

3. Release the infeed table lock and adjust the feed table flush with the out-feed table as illustrated in **Fig. 5.5**.

The infeed table should be exactly the same height as the out-feed table.

4. Lock the feed table in place.
5. Set the pointer shown in **Fig. 5.2** to 0 on the depth indicator scale.

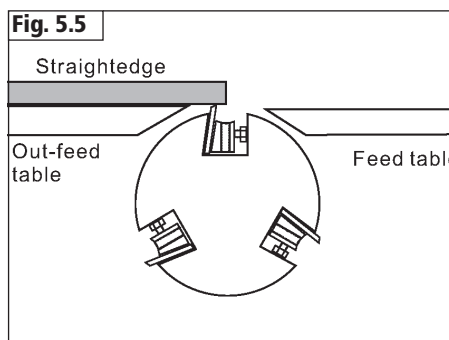
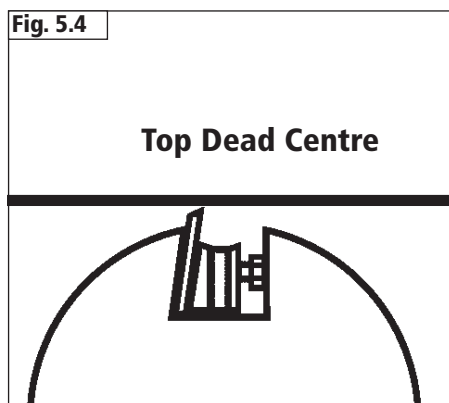
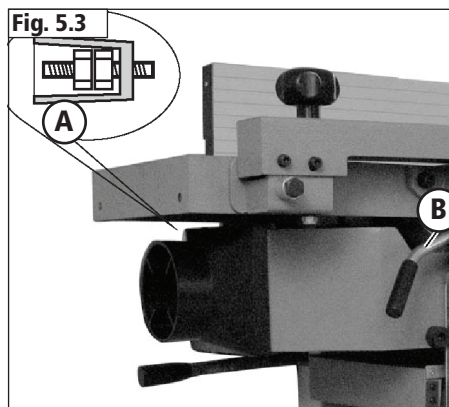



# 5. Operation

## Changeover from Planing to Thicknessing



### Warning: Remove the planer fence before changeover.

1. Open the table lock (A - Fig. 5.6) of the out-feed table and pull out the lever until it stops.
2. Now lift up the out-feed table.
3. Be sure the out-feed is fully raised and tilted by more than 90°.
4. Now you can raise the in feed table in the same way.
5. Finally, raise the combined extraction hood (C - Fig 5.6) to cover the cutter block.
6. Release (upwards) the thicknesser feed clutch lever (B - Fig 5.6).
7. Proceed in reverse order when closing the planer table.

**Attention:** Ensure that the thicknessing table is at least 160 mm below the cutterblock to allow the extraction hood to move freely between the surface planing and thicknessing positions.

### Adjusting the height for thicknessing

1. Measure the thickness of your work-piece.
2. Unscrew the lock lever (A - Fig 5.7) that clamps the thicknessing table.
3. Now raise the thicknessing table upwards via hand-wheel (B - Fig 5.7) to the desired height.
4. Retighten lock lever (A - Fig 5.7) to clamp the thicknessing table.

**Attention:** The maximum depth of cut is directly related to following points:

- The width of the work-piece.
- Type of wood (hardwood or softwood)
- Wood dampness
- Condition of planer blades
- Planer blade

### Rear Planer Fence Guard

This guard (A- Fig 5.8) is an integral part of the planer fence (B - Fig 5.8), so it will always be positioned over the planer cutter block. If necessary, adjust the planer fence across the cutter block by unscrewing the star knob (C - Fig 5.8).

### Working techniques



**Caution: Never place your hands on the work-piece over the planer cutter block.**

### Surface Planing

Cover the entire cutter block with protective bridge guard A and set it only slightly higher than the thickness of the workpiece.

At a work-piece thickness of 75 mm or greater, move the bridge guard up to the side of work-piece and let it rest on the planing table, (Fig 5.9). When the thickness of the work piece is less than 75 mm, the guard should be positioned above the work piece (Fig 5.10).

Your hands should be laid out flat onto your work-piece and push it forward to the cutter block. Allow your hands to glide over the planer bridge guard one by one. As soon as it is possible, push your work-piece with both hands on the out feed table. Bring back the plank over the planer bridge guard into starting position to perform a second pass.

Ensure that your hands are placed on the work-piece in a closed position with the thumbs against the closed hands.

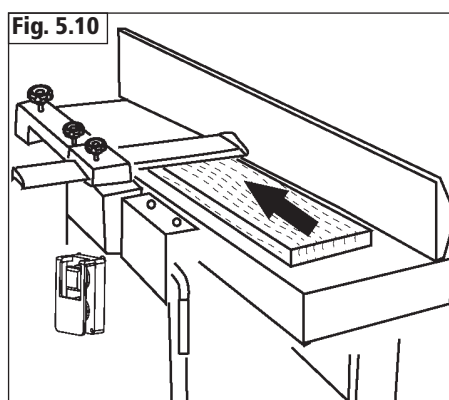
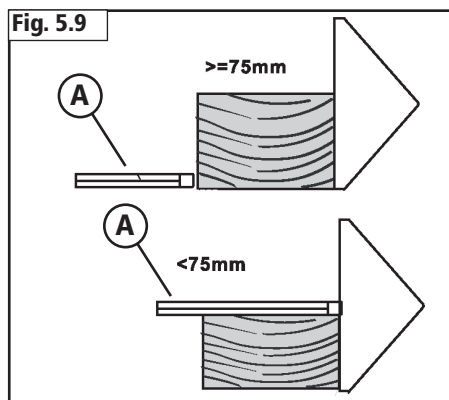
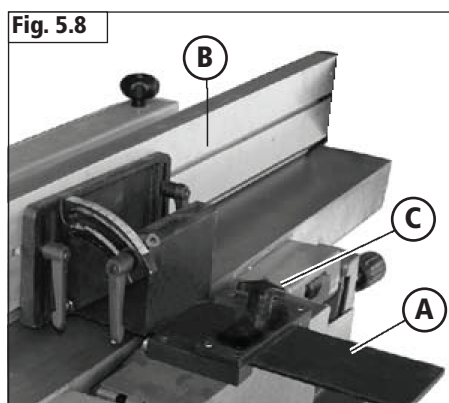
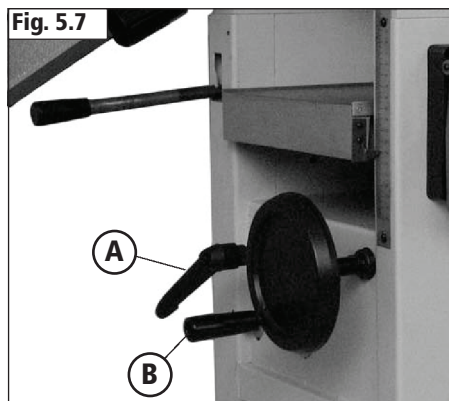
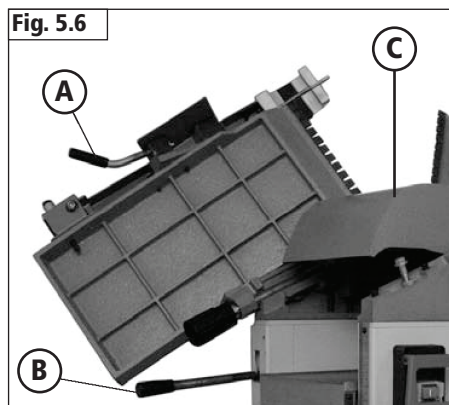

# 5. Operation

## Edge planing

Allow the planer bridge guard to rest on the planer table and cover the cutter block and allow for the width of the work-piece, **Fig. 5.11**.

Press the work-piece against the planer fence and guide evenly over the cutter block.

As soon as the work-piece extends far enough into the out feed table, place your left hand onto it and push it over the planer cutter block without stopping

## Tapering/edge beveling

In this mode, the longitudinal edges of a work-piece are beveled or tapered at any required angles.

Set protective bridge guard, **Fig 5.12**.

Set the joiner fence to required angle and press the work piece against the planer fence and guide evenly over the cutterblock.

To prevent the work-piece from slipping from the angled surface, press the workpiece mainly against the fence and only lightly against the planing table.

## Planing/surfacing of small work-piece

When surfacing or planing small work-pieces, use pushing strips A and a push block B, **Fig. 5.13**.

The push strip should not be thicker than the workpiece.

## Tapering /beveling small work-piece

You must always use a special jig for beveling small, narrow work-pieces.

This device can also be used to bevel long work-piece.

Attach the jig to the planer fence. Set the planer bridge guard all the way down and let the bridge guard contact the jig.



### Note:

**When surface planing, always feed the workpiece with a slow and consistent feed rate. Feeding the workpiece too quickly will reduce the quality of finish of the planed surface. Fine ridges or marks across the width of the workpiece are an indication that the feed rate is too fast.**

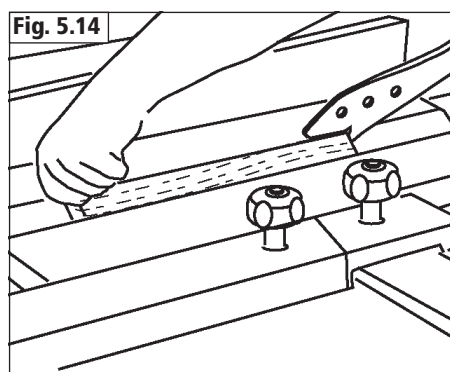
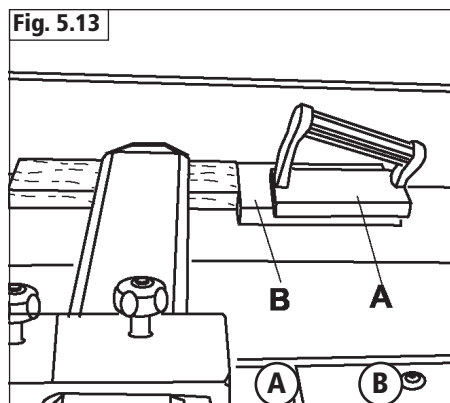
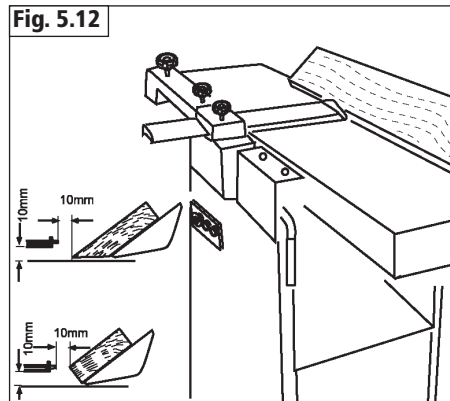
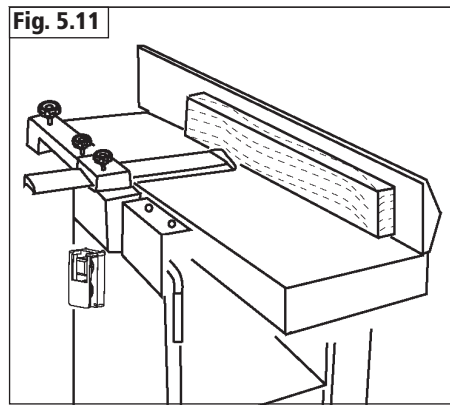

# 5. Operation

## Thickening

1. Adjust the thickening table height to suit the workpiece.
2. Activate the feed by raising the feed clutch lever (A - **Fig 5.15**) then release it.
3. Slide the work-piece into the machine until it is drawn in by the feed rollers.
4. If trouble occurs during thickening (e.g. protruding knot/nail or the work-piece become extremely tapered) switch off the feed immediately and lower the thickening table to free the workpiece.

A maximum of 2 work pieces can be fed through the thicknesser simultaneously. These must be pushed in at each end of the feed roller, **Fig 5.16**.



**Warning: If the workpiece becomes trapped when feeding into the thicknesser, immediately switch the machine off and disconnect from the power before attempting to free the work piece.**

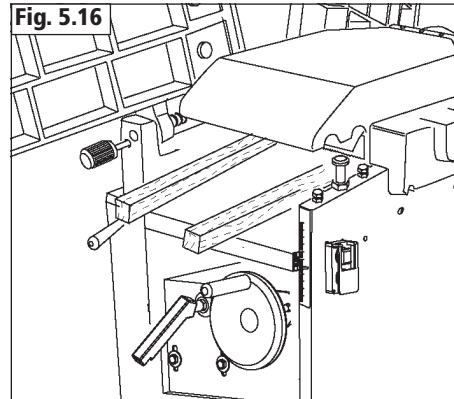
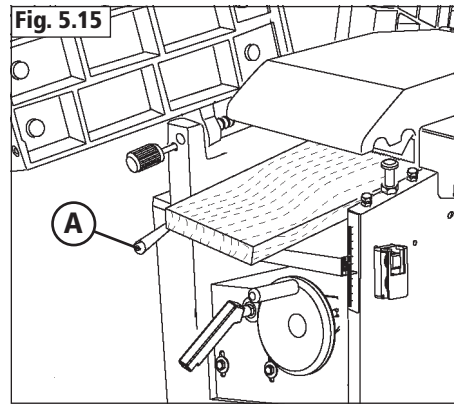

# 6. Maintenance

## Cleaning



**Caution:** Before carrying out any adjustments or maintenance ensure that the machine is isolated and disconnected from the electricity supply.

1. To avoid a build-up of wood dust, regularly clean the thicknesser drive gear using a brush or compressed air.
2. Lubricate all bearing points and chains regularly with a good quality silicone spray such as CWA195. Keep flat belt free of oil and grease.

**WARNING:** If blowing sawdust, wear proper eye protection to prevent debris from blowing into eyes.

3. Clean the thickening bed spindles on a regular basis to prevent the build-up of wood chips and dust, lubricate with silicone spray. Do not use ordinary oil as this will attract dust.
4. Keep infeed / outfeed tables and thickening bed free of resin. Clean regularly with white spirit, then coat with a light film of silicone spray such as Record Power CWA195 to enhance passage of workpiece on table **Fig 6.1**.

This machine will perform in conformity with the description contained in this manual when installed, operated, maintained and repaired in accordance with the instructions provided.

This machine must be checked periodically. Defective equipment (including power cable) should not be used. Parts that are broken, missing, plainly worn, distorted or contaminated, should be replaced immediately. Should such repair or replacement become necessary, it is recommended that such repairs be carried out by qualified persons.

This machine or any of its parts should not be altered or changed from standard specifications. The user of this machine shall have the sole responsibility for any malfunction which results from improper use or unauthorised modification from standard specification, faulty maintenance, damage or improper repair.

### Kickback guards (A) (Fig 6.2)

Remove traces of resin as required. When lifted, the guards must drop back into position by their own weight. Test their function before each use.

### Feed rollers (B) (Fig 6.2)

Remove traces of resin monthly, when marks appear in the planer workpieces, or in the event of poor feed.

### Transmission (Fig 6.3)

Ensure that chain A is sufficiently lubricated (Normal machine grease). The friction wheel B is a consumable part and must be replaced as needed.

Fig 6.1

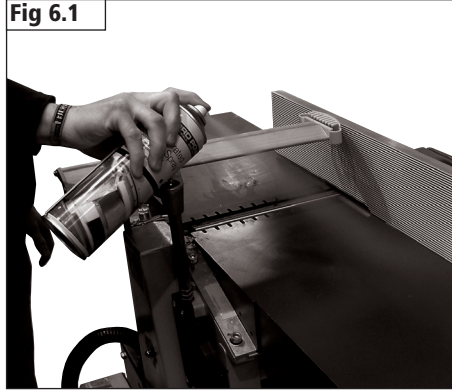

Fig. 6.2

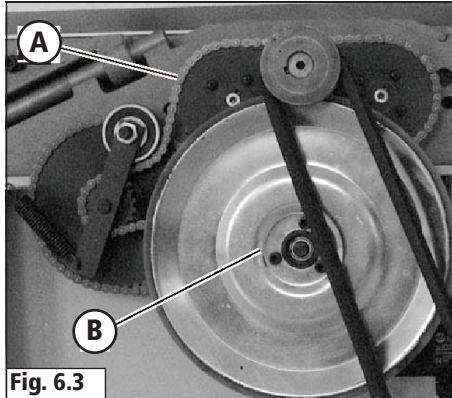
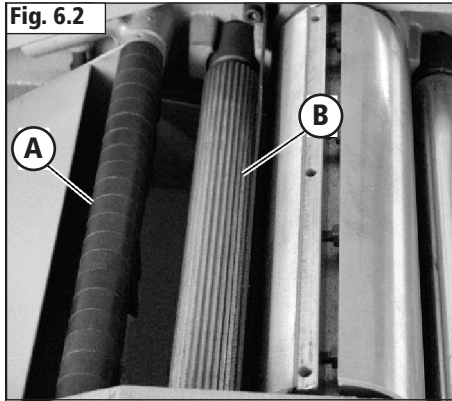

Fig. 6.3

# 6. Maintenance



The cutter block in this machine is designed to hold three blades. Never attempt to use the machine if any of the blades are missing or damaged. All blades used must conform to BS EN 847-1.

## Changing the Planer Blades

### Check the height of the Blade

The blades should be periodically replaced or adjusted. Adjustments should be as precise as possible with tolerances within 1- 1.1mm to prolong the sharpness of the blades edges.

Improperly adjusted Blades can unbalance the cutterblock and shorten bearing life, as well as produce substandard thicknessing or planing results.

The planer blades fitted to this machines are made from high speed steel and can be reshaped periodically to maintain the cutting edge and optimise performance of the machine. The process of reshaping blades will remove a small amount of material from the blade's edge and therefore will reduce the overall width of the blade. Never attempt to use blades that have been reduced by more than 25% of their original width. Always ensure that the blade can be held securely by the blade holder. Replace defective blades immediately.



**Caution: Before carrying out any adjustments or maintenance ensure that the machine is isolated and disconnected from the electricity supply.**

1. Remove the cutter-block guard to expose the top of the cutter-block.
2. Carefully turn the cutter-block until the first blade is at top dead centre.
3. Using the cutter-block gauge check the blade height.

The gauge should sit solidly with the pads resting on the cutter-block. If the knife is adjusted properly, the knife is barely touching the middle slot of cutterblock gauge. If the knife does not touch the middle slot, or if the knife causes the pads of gauge to not sit flush on the cutter-block, the knives need to be adjusted. The Blades should protrude from the cutter block by a maximum of 1.1mm.

### Changing the blades



**Caution: Before carrying out any adjustments or maintenance ensure that the machine is isolated and disconnected from the electricity supply.**

1. Remove the cutter-block guard to expose the top of the cutter-block.
2. Carefully turn the cutter-block until the first blade is at top dead centre.
3. Release all blade holder screws (A - Fig. 6.5) of each blade, by screwing them into the blade holder.
4. Remove the blade holder (B - Fig. 6.5) and planer blade (C - Fig. 6.5) one at a time.
5. Repeat this process with all blades.
6. Clean the planer blades, blade holders and planer cutter block of traces of resin as thoroughly as possible.
7. Reinstall the planer blades and blade holders, tighten the blade holder screws lightly at first.
8. Check the height of blade (see "Check the height of blade").
9. Turn the jack screw to adjust the height of knife, (Fig. 6.6)
10. Finally tighten all blade holder screws, (A - Fig. 6.5) by unscrewing them from the blade holder.

### Drive belts

Over time, the drive belt tension may loosen. In this case, the belt must either be tightened or replaced.

Check the belt monthly for cracks or lateral tears.

Replace the belt if necessary.

Loosen motor mounting bolts A (Fig 6.7).

Use the weight of the motor to tension the drive belt. When the correct tension is applied, tighten the motor mounting bolts A, (Fig 6.7).

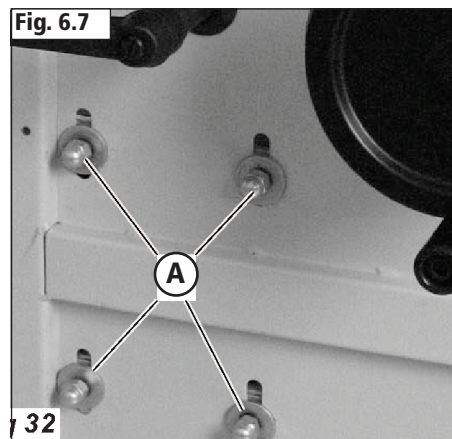
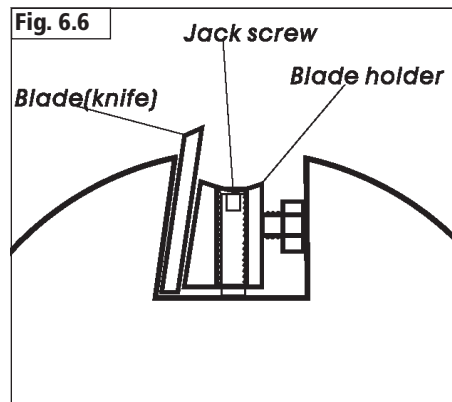
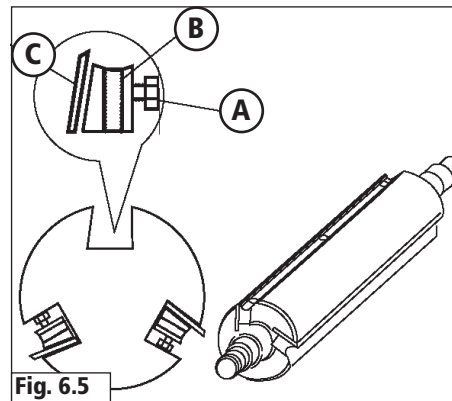
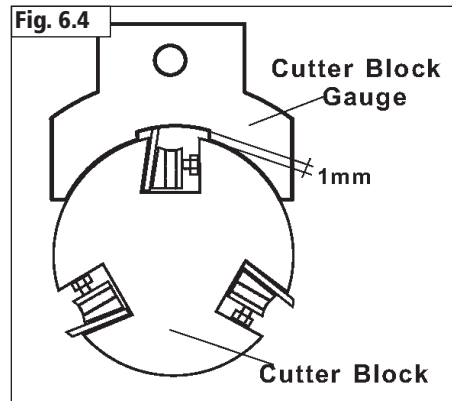



# 7. Dust Extraction

## 7.1 The importance of dust extraction

Before the machine is started, ensure that adequate dust extraction provisions have been installed. Dust extraction is extremely important not only for health and safety but also for the correct upkeep of the machine. Saw dust can cause the machine not to operate properly or even fail completely. By keeping the machine free of large amounts of waste the performance will be optimised.

If large amounts of MDF or toxic woods are to be cut we recommend that there is a good ventilation system in place and that a particle mask is worn as minimum protection.

In addition, it is recommended that air filters are used in all workshops to ensure collection of potentially harmful airborne particles which are not collected directly from the machine.

## 7.2 Record Power Extractors

Record Power offer a range of high quality dust extractors, starting at the single motor 45 litre RSDE1 right up to the 200 litre twin motor DX5000. We offer both drum and bag type extractors high filtration models filter down to 0.5 micron providing protection from harmful fine dusts such as MDF. Chip collectors filter down to 5 micron. All Record Power dust extractors & chip collectors have 100mm inlets and hoses.

### RSDE1 High Filtration Dust Extractor

Drum type extractor, 45 litre capacity, single 1 kW motor, suitable for intermittent use i.e must be switched off for 20 minutes every hour.

**0.5 micron filtration; suitable for MDF**

### RSDE2 High Filtration Dust Extractor

Drum type extractor, 50 litre capacity, single 1 kW motor, suitable for intermittent use i.e must be switched off for 20 minutes every hour.

**0.5 micron filtration; suitable for MDF**

### DX1000 High Filtration Dust Extractor

Drum type extractor, 45 litre capacity, single 1 kW motor, suitable for intermittent use i.e must be switched off for 20 minutes every hour.

**0.5 micron filtration; suitable for MDF**

### DX4000 High Filtration Dust Extractor

Drum type extractor, 80 litre capacity, twin 1 kW motor, suitable for heavy usage i.e if one motor is switched off for 20 minutes then the other can be used thus enabling continuous usage. Or both motors can be used simultaneously giving maximum suction but in this mode the extractor must be switched off for 20 minutes every hour.

**0.5 micron filtration; suitable for MDF**

### DX5000 High Filtration Dust Extractor

Bag type extractor, 200 litre capacity, twin 1 kW motor, suitable for heavy usage i.e if one motor is switched off for 20 minutes then the other can be used thus enabling continuous usage. Or both motors can be used simultaneously giving maximum suction but in this mode the extractor must be switched off for 20 minutes every hour.

**0.5 micron filtration; suitable for MDF**

### CX2600 Chip collector

Large capacity chip collector, with a powerful 0.37 kW induction motor. An extremely smooth running unit suitable for continuous usage. Very quiet impeller system extracts dust and chippings.

**5 micron filtration; unsuitable for MDF**

### CX3000 Chip collector

Larger capacity chip collector, with a more powerful 0.75 kW induction motor and heavy duty construction. An extremely smooth running unit suitable for continuous usage. Very quiet impeller system extracts dust and chippings.

**5 micron filtration; unsuitable for MDF**

### AC400 Two Stage Air Filter

Useful for reducing nuisance dust, particularly in smaller workshops. This unit provides effective two stage filtration for areas up to 113 M<sup>3</sup>.

**1 micron filtration**

### AC2 Three Stage Air Filter

This triple stage filter offers highly effective filtering of particles down to 1 micron. Ideal for use in medium to large workshops up to 212 M<sup>3</sup>.

**1 micron filtration**

|  | RSDE1            | RSDE2            | DX1000           | DX4000           | DX5000           | CX2600           | CX3000           | AC400            | AC2              |
|--|------------------|------------------|------------------|------------------|------------------|------------------|------------------|------------------|------------------|
| <b>Bandsaws</b><br><b>Circular saws</b><br><b>Sanders</b><br>Intermittent usage                  | ✓<br>Recommended | ✓<br>Recommended | ✓<br>Recommended | ✓<br>Recommended | ✓<br>Recommended |                  |                  |                  |                  |
| <b>Bandsaws</b><br><b>Circular saws</b><br><b>Sanders</b><br>Heavy usage                         |                  |                  |                  | ✓<br>Recommended | ✓<br>Recommended |                  |                  |                  |                  |
| <b>Planer Thicknessers</b><br><b>Spindle Moulders</b><br><b>Universals</b><br>Intermittent usage |                  |                  |                  | ✓<br>Can be used | ✓<br>Recommended | ✓<br>Recommended | ✓<br>Recommended |                  |                  |
| <b>Planer Thicknessers</b><br><b>Spindle Moulders</b><br><b>Universals</b><br>Heavy usage        |                  |                  |                  | ✓<br>Can be used | ✓<br>Recommended | ✓<br>Recommended | ✓<br>Recommended |                  |                  |
| <b>Dust Extraction System</b><br>Intermittent usage  |                  |                  |                  | ✓<br>Can be used | ✓<br>Recommended |                  |                  |                  |                  |
| <b>General Workshop Air Filtration</b><br>Heavy usage  |                  |                  |                  |                  |                  |                  |                  | ✓<br>Recommended | ✓<br>Recommended |



# 8. Electrical Connection & Wiring Diagram

Machines supplied for use in the UK are fitted with a 3 pin plug conforming to BS1363, fitted with a fuse conforming to BS1362 and appropriate to the current rating of the machine.

Machines supplied for use in other countries within the European Union are fitted with a 2 pin Schuko plug conforming to CEE 7/7.

Machines supplied for use in Australia & New Zealand are fitted with a 3 pin plug conforming to AS/NZS3112.

In all cases, if the original plug or connector has to be replaced for any reason, the wires within the mains power cable are colour coded as follows:

## 230 V (Single Phase)

Brown: Live (L)  
 Blue: Neutral (N)  
 Green and Yellow: Earth (E)

The wire coloured brown must always be connected to the terminal marked 'L' or coloured red.

The wire coloured blue must always be connected to the terminal marked 'N' or coloured black.

The wire coloured green and yellow must always be connected to the terminal marked 'E' or with the earth symbol:



or coloured green / green and yellow.

It is important that the machine is effectively earthed. Some machines will be clearly marked with the double insulated logo:



In this case there will not be an earth wire within the circuit.

In the case of the BS1363 plug for use in the UK, always ensure that it is fitted with a fuse conforming to BS1362 appropriate to the rating of the

machine. If replacing the original fuse, always fit a fuse of equivalent rating to the original. Never fit a fuse of a higher rating than the original. Never modify the fuse or fuse holder to accept fuses of a different type or size.

Where the current rating of the machine exceeds 13 A at 230 V, or if the machine is designated for use on a 400 V 3 phase supply a connector conforming to BS4343 (CEE17 / IEC60309) will be used.

230 V machines will be fitted with a blue 3 pin connector. The wiring for this type of this connector will be the same as shown above.

400 V, 3 phase machines will be fitted with a red 4 or 5 pin connector. The wiring for this type of connector is as shown below:

## 400 V (3 phase)

Brown: Live (L1)  
 Black: Live (L2)  
 Grey: Live (L3)  
 Blue: Neutral (N)  
 Green and Yellow: Earth (E)

The wire coloured brown must always be connected to the terminal marked 'L1'.

The wire coloured black must always be fitted to the terminal marked 'L2'.

The wire coloured grey must always be connected to the terminal marked 'L3'.

The wire coloured blue must always be connected to the terminal marked 'N' or coloured black.

The wire coloured green and yellow must always be connected to the terminal marked 'E' or with the earth symbol

If in doubt about the connection of the electrical supply, always consult a qualified electrician.

## 1phase Motor

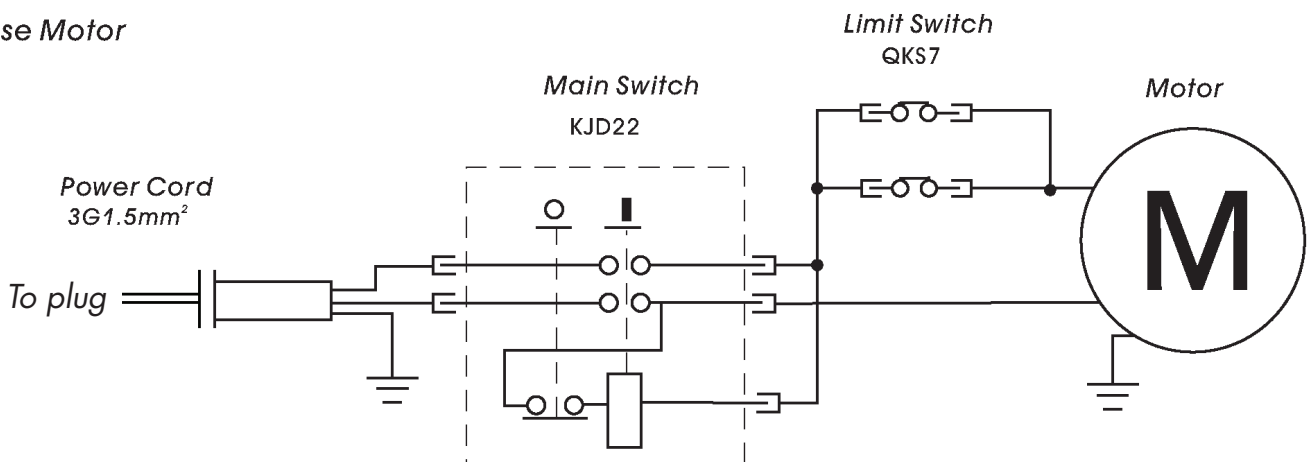

# 9. Troubleshooting

| Problem   | Cause  | Solution   |
|---|--|--|
| Motor is slow or weak:  | <ol style="list-style-type: none"> <li>1. Voltage from source is low.</li> <li>2. Windings are burned out or open.</li> <li>3. Power switch is defective.</li> <li>4. Circuit is overloaded with appliances, lights, or other electrically powered equipment.</li> </ol> | <ol style="list-style-type: none"> <li>1. Request a voltage check from local power company.</li> <li>2. Have the motor checked / repaired.</li> <li>3. Have the power switch replaced.</li> <li>4. Do not use other appliances or electrically powered equipment on the same circuit when using this machine.</li> </ol> |
| Motor overheats:  | <ol style="list-style-type: none"> <li>1. Motor is overloaded.</li> <li>2. Dull planer blades.</li> </ol>  | <ol style="list-style-type: none"> <li>1. Request a voltage check from the local power company.</li> <li>2. Replace the planer blades.</li> </ol>  |
| When milling, the cut burns the work-piece or stalls the motor: | <ol style="list-style-type: none"> <li>1. Planer blades are dull.</li> <li>2. Work-piece is warped.</li> </ol>   | <ol style="list-style-type: none"> <li>1. Sharpen or replace the Planer blades.</li> <li>2. Replace the work-piece.</li> </ol>   |
| Height handles are hard to turn:                                | <ol style="list-style-type: none"> <li>1. Dust has collected on the mechanisms inside the base.</li> </ol>   | <ol style="list-style-type: none"> <li>1. Clean and lubricate the mechanisms inside the base.</li> </ol>   |
| Planer thicknesser vibrates excessively:                        | <ol style="list-style-type: none"> <li>1. Floor surface is uneven.</li> <li>2. V-belt is damaged.</li> <li>3. Planer blades are damaged.</li> <li>4. Loose bolt, screws or nuts.</li> </ol>  | <ol style="list-style-type: none"> <li>1. Readjust the machine.</li> <li>2. Replace the V-belt.</li> <li>3. Replace the planer knives.</li> <li>4. Tighten all hardware.</li> </ol>  |
| Planer & thicknesser does not start:                            | <ol style="list-style-type: none"> <li>1. Power cord is not plugged in.</li> <li>2. Circuit fuse is blown.</li> <li>3. Circuit breaker is tripped.</li> <li>4. Motor cord or switch is damaged.</li> <li>5. Microswitches not made.</li> </ol>                           | <ol style="list-style-type: none"> <li>1. Plug in power cord to volt electrical outlet.</li> <li>2. Replace circuit fuse.</li> <li>3. Reset circuit breaker.</li> <li>4. Have the motor cord or switch replaced.</li> <li>5. Switch microswitch.</li> </ol>  |
| Power Switch does not operate:                                  | <ol style="list-style-type: none"> <li>1. Power switch contacts are burned out.</li> <li>2. Capacitor is defective.</li> <li>3. Wiring connections are loose or damaged.</li> </ol>  | <ol style="list-style-type: none"> <li>1. Have the power switch replaced.</li> <li>2. Request a voltage check from the local power company.</li> <li>3. Have the capacitor replaced.</li> <li>4. Have the wiring connections checked / repaired.</li> </ol>  |
| Fuses or circuit breakers open frequently:                      | <ol style="list-style-type: none"> <li>1. Motor is overloaded.</li> <li>2. Fuses or circuit breakers are wrong size or defective.</li> <li>3. Dull planer blades.</li> <li>4. Power Switch is defective.</li> </ol>  | <ol style="list-style-type: none"> <li>1. Feed work-piece more slowly.</li> <li>2. Replace fuses or circuit breakers.</li> <li>3. Replace the planer blades.</li> <li>4. Have the power switch replaced.</li> </ol>  |
| Motor stalls, blows fuses or trips circuit breakers:            | <ol style="list-style-type: none"> <li>1. Motor is overloaded.</li> <li>2. Dull planer blades.</li> <li>3. Fuses or circuit breakers are wrong size or defective.</li> <li>4. Feeding work-piece too rapidly.</li> </ol>   | <ol style="list-style-type: none"> <li>1. Request a voltage check from the local power company.</li> <li>2. Replace the planer blades.</li> <li>3. Replace fuses or circuit breakers.</li> <li>4. Feed work-piece more slowly.</li> </ol>  |
| Machine is noisy when running:                                  | <ol style="list-style-type: none"> <li>1. Motor is loose or defective.</li> <li>2. Check feed roller drive chain.</li> </ol>   | <ol style="list-style-type: none"> <li>1. Have the motor checked/repared.</li> <li>2. Adjust tension.</li> </ol>   |

**Warning:** To prevent personal injury and/or damage to the planer thicknesser , maintenance and repairs should be done only by a qualified technician.

# 10. Parts List & Diagrams

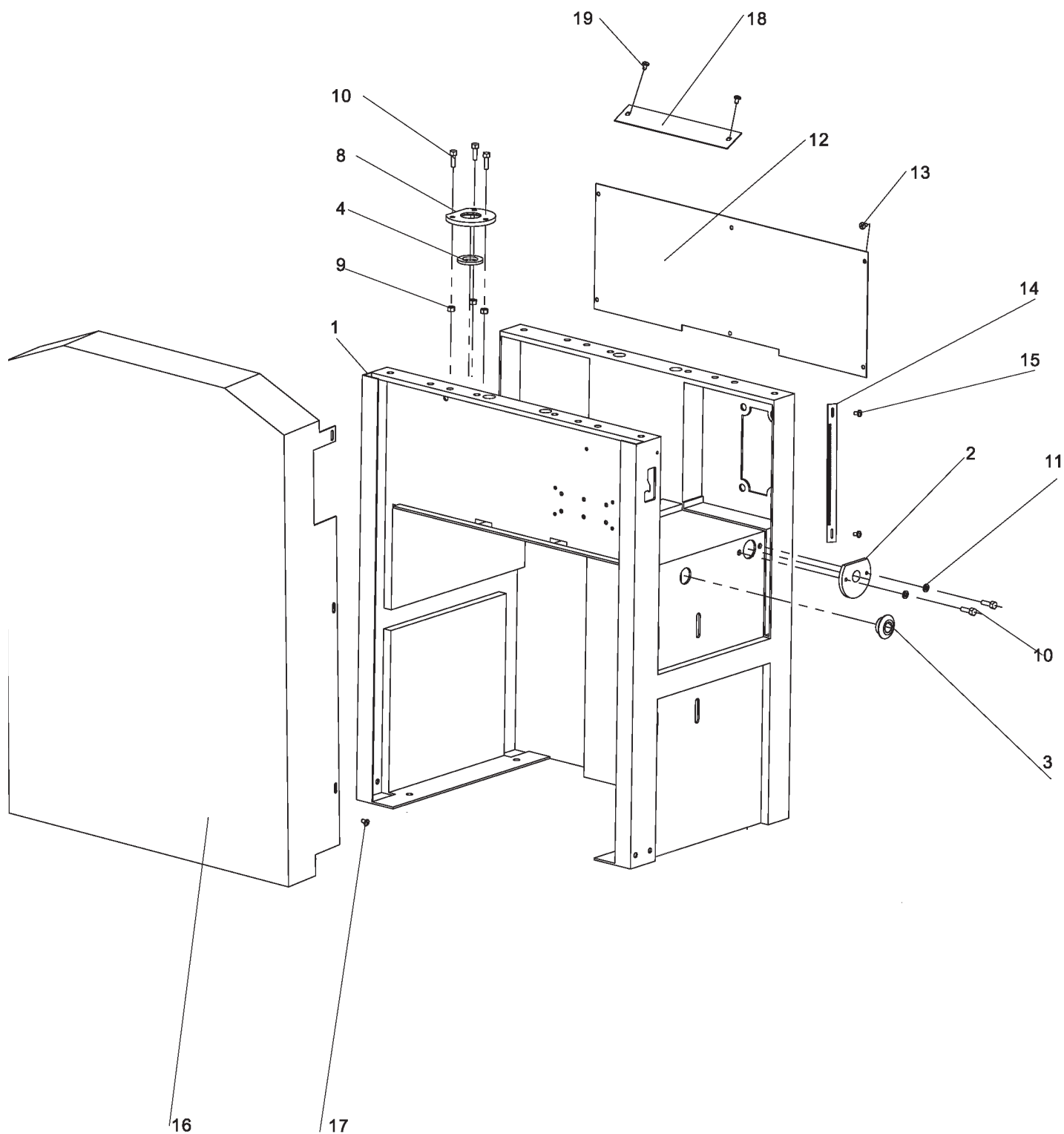

| NO. | DESCRIPTION                  | Q'TY |
|-----|------------------------------|------|
| 1   | Main frame                   | 1    |
| 2   | Shaft seat, thickening table | 1    |
| 3   | Seat, lock lever             | 1    |
| 4   | Oil seal                     | 1    |
| 8   | Seat, bearing                | 1    |
| 9   | Hex lock nut                 | 3    |
| 10  | Hex screw M6x16              | 5    |
| 11  | Washer 6mm                   | 2    |

| NO. | DESCRIPTION                | Q'TY |
|-----|----------------------------|------|
| 12  | Inner shield               | 1    |
| 13  | Cross sunk head screw M5x6 | 5    |
| 14  | Scale, thickening height   | 1    |
| 15  | Pan head screw M5x6        | 5    |
| 16  | Gear cover                 | 1    |
| 17  | Pan head screw M5x6        | 6    |
| 18  | Cover plate                | 2    |
| 19  | Pan head screw M5x8        | 4    |



# 10. Parts List & Diagrams - cont.

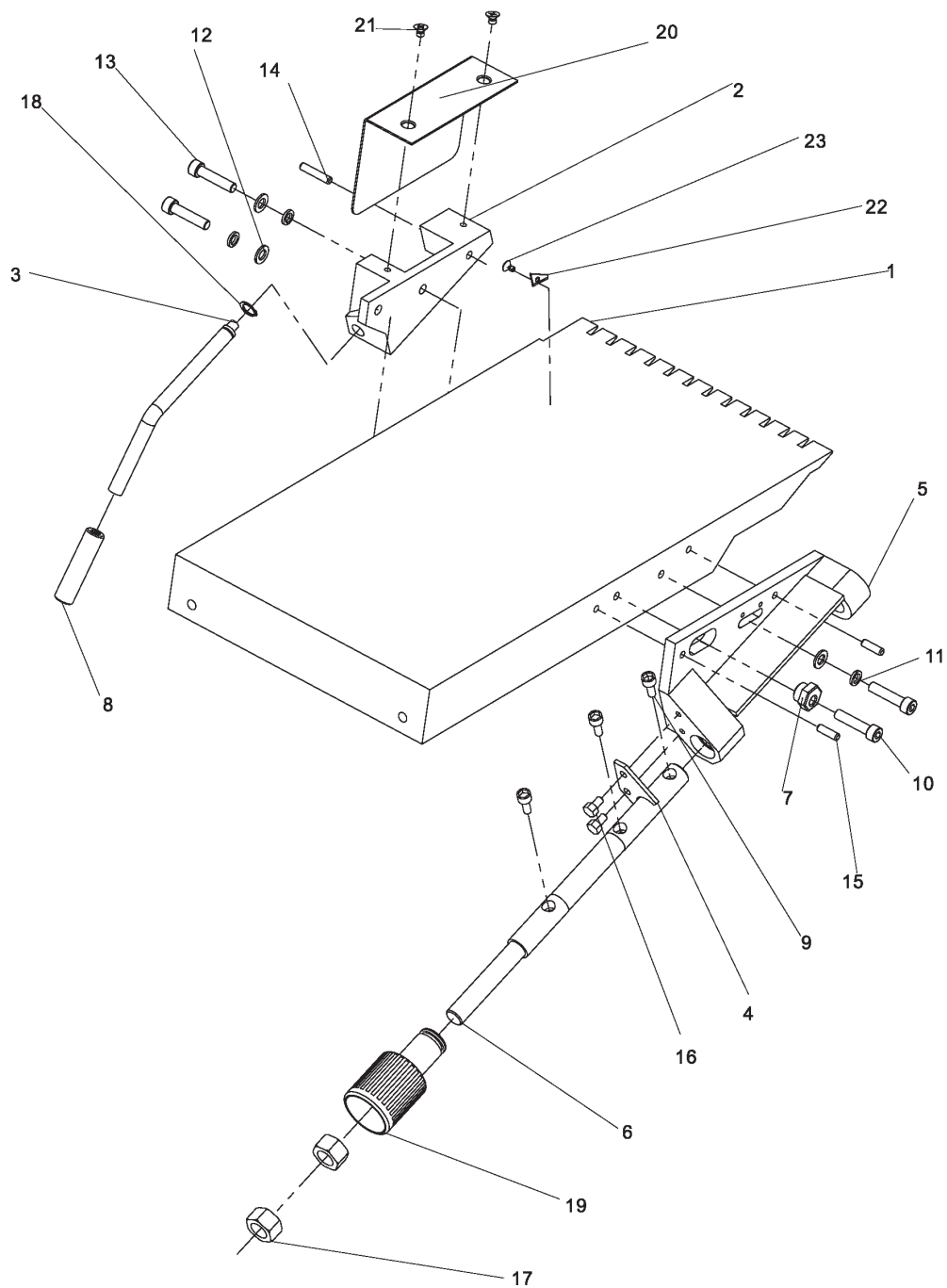

| NO. | DESCRIPTION        | Q'TY | NO. | DESCRIPTION                | Q'TY |
|-----|--------------------|------|-----|----------------------------|------|
| 1   | Feed table, planer | 1    | 13  | Allen screw M8x25          | 2    |
| 2   | Table lock seat    | 1    | 14  | Roll pin D6x30             | 1    |
| 3   | Table lock         | 1    | 15  | Roll pin D6x20             | 2    |
| 4   | Fork               | 1    | 16  | Hex head screw M6x12       | 2    |
| 5   | Table swing seat   | 1    | 17  | Hex nut M16                | 2    |
| 6   | Table swing shaft  | 1    | 18  | Circle ring 12mm           | 1    |
| 7   | Eccentric seat     | 1    | 19  | Handle, table swing        | 1    |
| 8   | Sleeve, table lock | 1    | 20  | Shield plate               | 1    |
| 9   | Allen screw M6x20  | 3    | 21  | Cross sunk head screw M6x8 | 2    |
| 10  | Allen screw M8x30  | 2    | 22  | Pointer                    | 1    |
| 11  | Spring washer 8mm  | 3    | 23  | Pan head screw M4x8        | 1    |
| 12  | Washer 8mm         | 3    |     |                            |      |

# 10. Parts List & Diagrams - cont.

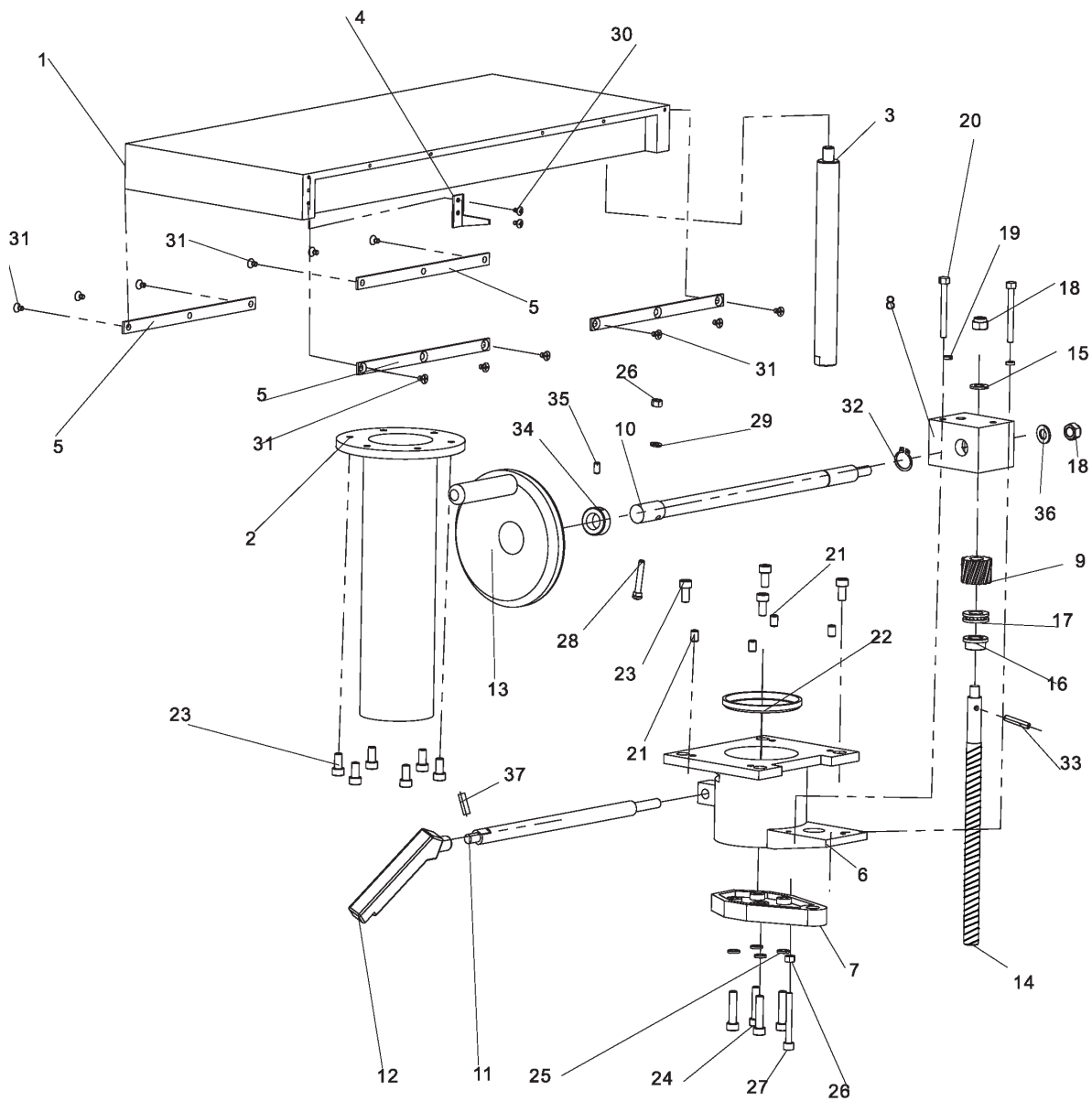

| NO. | DESCRIPTION           | Q'TY | NO. | DESCRIPTION                | Q'TY |
|-----|-----------------------|------|-----|----------------------------|------|
| 1   | Ticknessing table     | 1    | 20  | Hex head screw M6x60       | 2    |
| 2   | Raise guide rail      | 1    | 21  | Set screw M8x12            | 4    |
| 3   | Special guide         | 1    | 22  | Oil seal                   | 1    |
| 4   | Height indicator      | 1    | 23  | Allen screw M8x16          | 10   |
| 5   | Edge -plate           | 4    | 24  | Allen screw M8x35          | 4    |
| 6   | Fixed guide rail      | 1    | 25  | Spring washer 8mm          | 4    |
| 7   | Screw guide           | 1    | 26  | Hex nut M6                 | 2    |
| 8   | Raise gear seat       | 1    | 27  | Allen screw M6x55          | 1    |
| 9   | Raise gear            | 1    | 28  | Carriage bolt M6x40        | 1    |
| 10  | Raise shaft           | 1    | 29  | Washer 6mm                 | 1    |
| 11  | Clamp rod             | 1    | 30  | Pan head screw M4x10       | 2    |
| 12  | Clamp lever           | 1    | 31  | Cross sunk head screw M4x8 | 12   |
| 13  | Handle wheel, raising | 1    | 32  | Circle ring 18mm           | 1    |
| 14  | Raise guide rod       | 1    | 33  | Roll pin 5x10              | 1    |
| 15  | Spacer                | 1    | 34  | Collar                     | 1    |
| 16  | Spacer                | 1    | 35  | Set screw M8x8             | 1    |
| 17  | Thrust bearing 51102  | 1    | 36  | Washer 10mm                | 1    |
| 18  | Hex lock nut M10      | 2    | 37  | Roll pin 2.5x12            | 1    |
| 19  | Spring washer 6mm     | 2    |     |                            |      |



# 10. Parts List & Diagrams - cont.

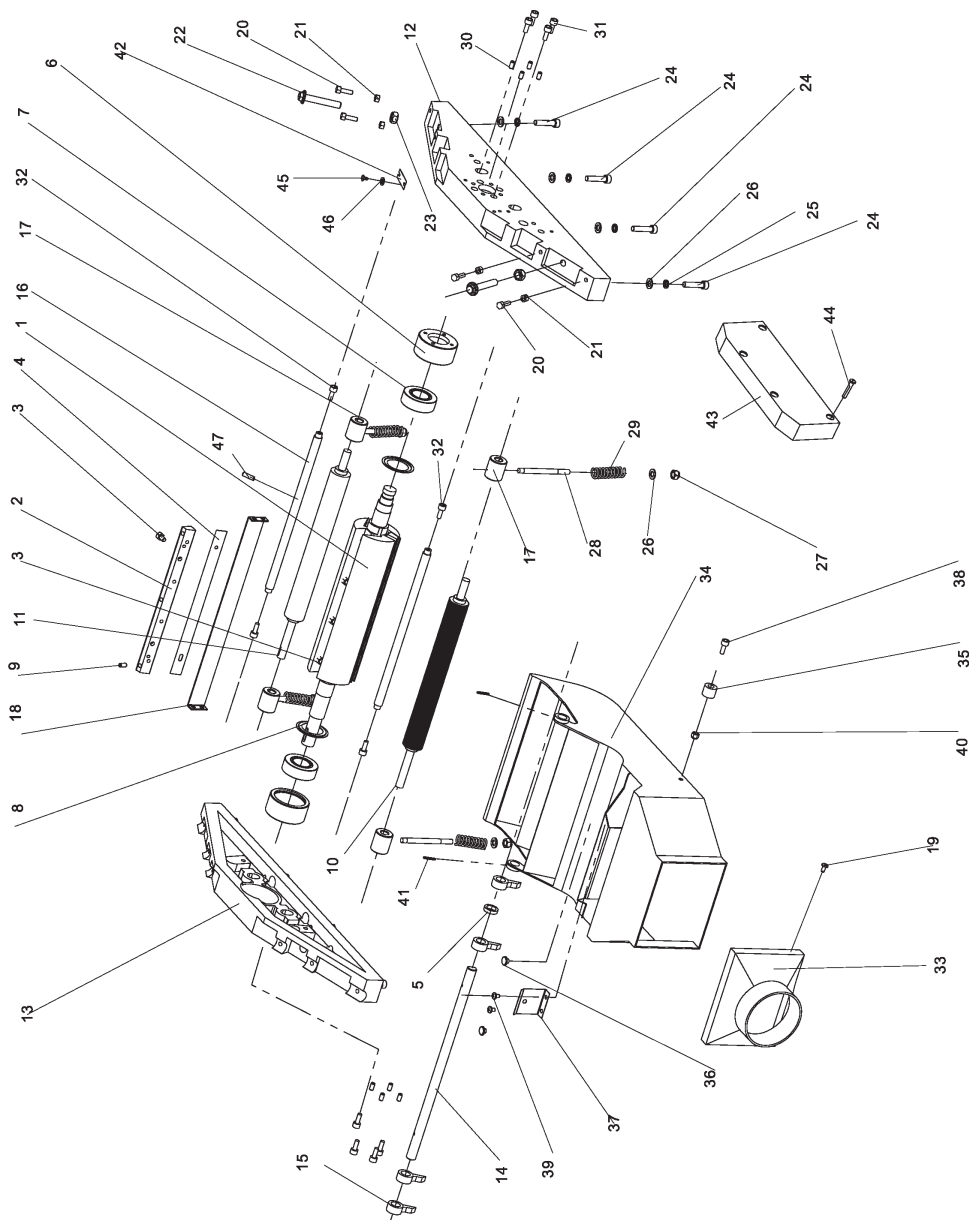

| NO. | DESCRIPTION           | Q'TY | NO. | DESCRIPTION                | Q'TY |
|-----|-----------------------|------|-----|----------------------------|------|
| 1   | Cutter block          | 1    | 20  | Hex head screw M6x60       | 2    |
| 2   | Blade holder          | 3    | 21  | Set screw M8x12            | 4    |
| 3   | Hex head screw M6x12  | 12   | 22  | Oil seal                   | 1    |
| 4   | Blade                 | 3    | 23  | Allen screw M8x16          | 10   |
| 5   | Spacer                | 16   | 24  | Allen screw M8x35          | 4    |
| 6   | Bearing cover         | 2    | 25  | Spring washer 8mm          | 4    |
| 7   | Bearing 6205          | 2    | 26  | Hex nut M6                 | 2    |
| 8   | Circle ring 52 mm     | 2    | 27  | Allen screw M6x55          | 1    |
| 9   | Set screw M6x12       | 6    | 28  | Carriage bolt M6x40        | 1    |
| 10  | In-feed roller        | 1    | 29  | Washer 6mm                 | 1    |
| 11  | Out-feed roller       | 1    | 30  | Pan head screw M4x10       | 2    |
| 12  | Bearing house, front  | 1    | 31  | Cross sunk head screw M4x8 | 12   |
| 13  | Handle wheel, raising | 1    | 32  | Circle ring 18mm           | 1    |
| 14  | Raise guide rod       | 1    | 33  | Roll pin 5x10              | 1    |
| 15  | Spacer                | 1    | 34  | Collar                     | 1    |
| 16  | Spacer                | 1    | 35  | Set screw M8x8             | 1    |
| 17  | Thrust bearing 51102  | 1    | 36  | Washer 10mm                | 1    |
| 18  | Hex lock nut M10      | 2    | 37  | Roll pin 2.5x12            | 1    |
| 19  | Spring washer 6mm     | 2    |     |                            |      |

# 10. Parts List & Diagrams - cont.

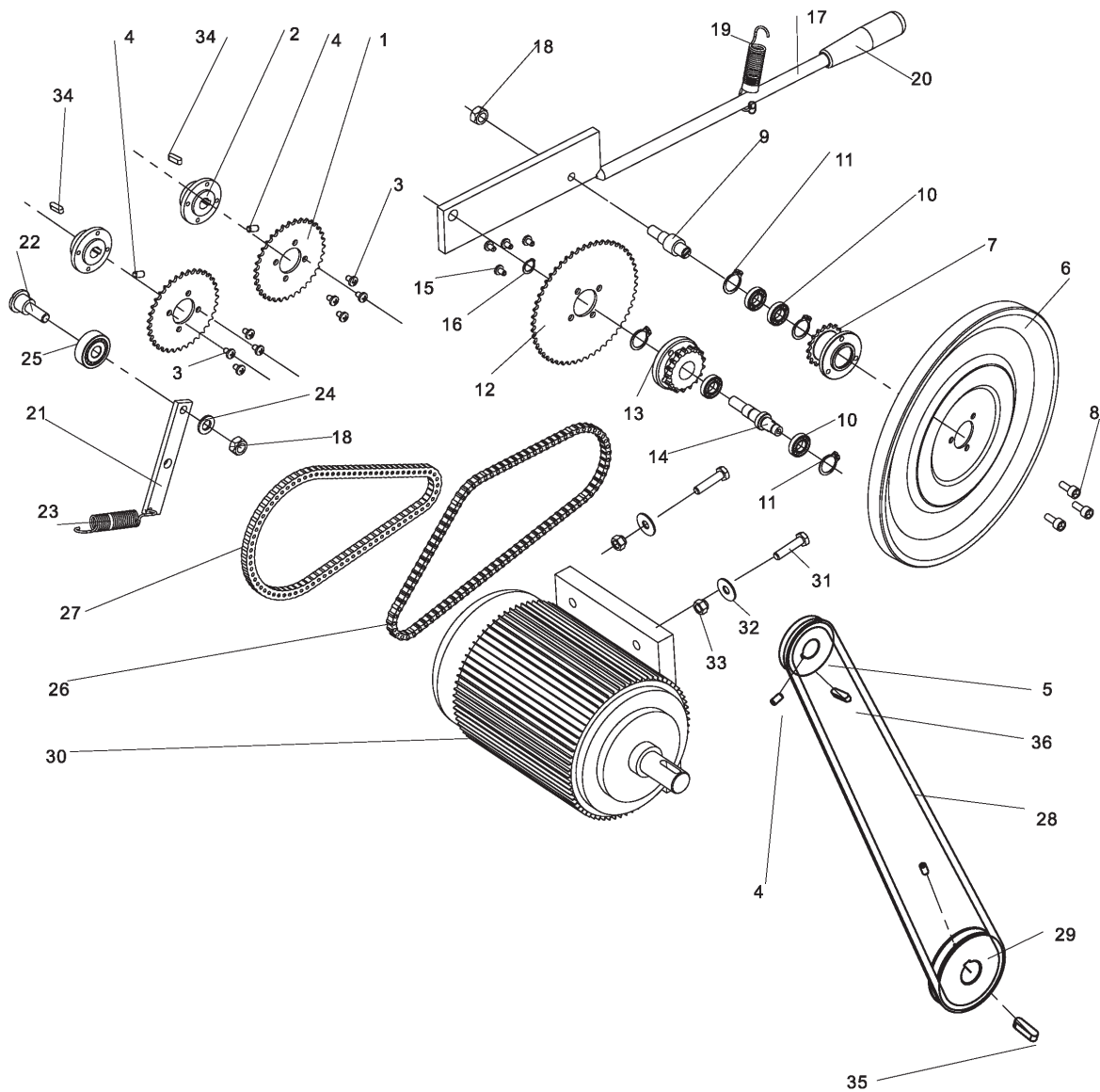

| NO. | DESCRIPTION           | Q'TY | NO. | DESCRIPTION                     | Q'TY |
|-----|-----------------------|------|-----|---------------------------------|------|
| 1   | Sprocket A            | 2    | 19  | Spring                          | 1    |
| 2   | Flange                | 2    | 20  | Handle, friction lever          | 1    |
| 3   | Pan head screw M5x8   | 8    | 21  | Tension plate                   | 1    |
| 4   | Set screw M6x6        | 4    | 22  | Tension rod                     | 1    |
| 5   | Shaft pulley          | 1    | 23  | Spring                          | 1    |
| 6   | Wheel friction        | 1    | 24  | Washer 10mm                     | 1    |
| 7   | Sprocket B            | 1    | 25  | Bearing 6303                    | 1    |
| 8   | Allen screw M6x12     | 3    | 26  | Feeding chain                   | 1    |
| 9   | Shaft, friction wheel | 1    | 27  | Chain                           | 1    |
| 10  | Bearing 61901         | 4    | 28  | Belt XPZ1250                    | 1    |
| 11  | Circle ring 24mm      | 4    | 29  | Motor pulley                    | 1    |
| 12  | Sprocket C            | 1    | 30  | Motor                           | 1    |
| 13  | Sprocket D            | 1    | 31  | Hex head screw w.flange M8 x 25 | 4    |
| 14  | Shaft, sprocket       | 1    | 32  | Special flat washer 8mm         | 4    |
| 15  | Pan head screw M6 x 8 | 4    | 33  | Cap nut M8                      | 4    |
| 16  | Circle ring 12mm      | 1    | 34  | Flat key 5x5x16                 | 2    |
| 17  | Lever, friction wheel | 1    | 35  | Flat key 8x7x28                 | 1    |
| 18  | Hex nut M10           | 2    | 36  | Flat key 6x6x16                 | 1    |

# 10. Parts List & Diagrams - cont.

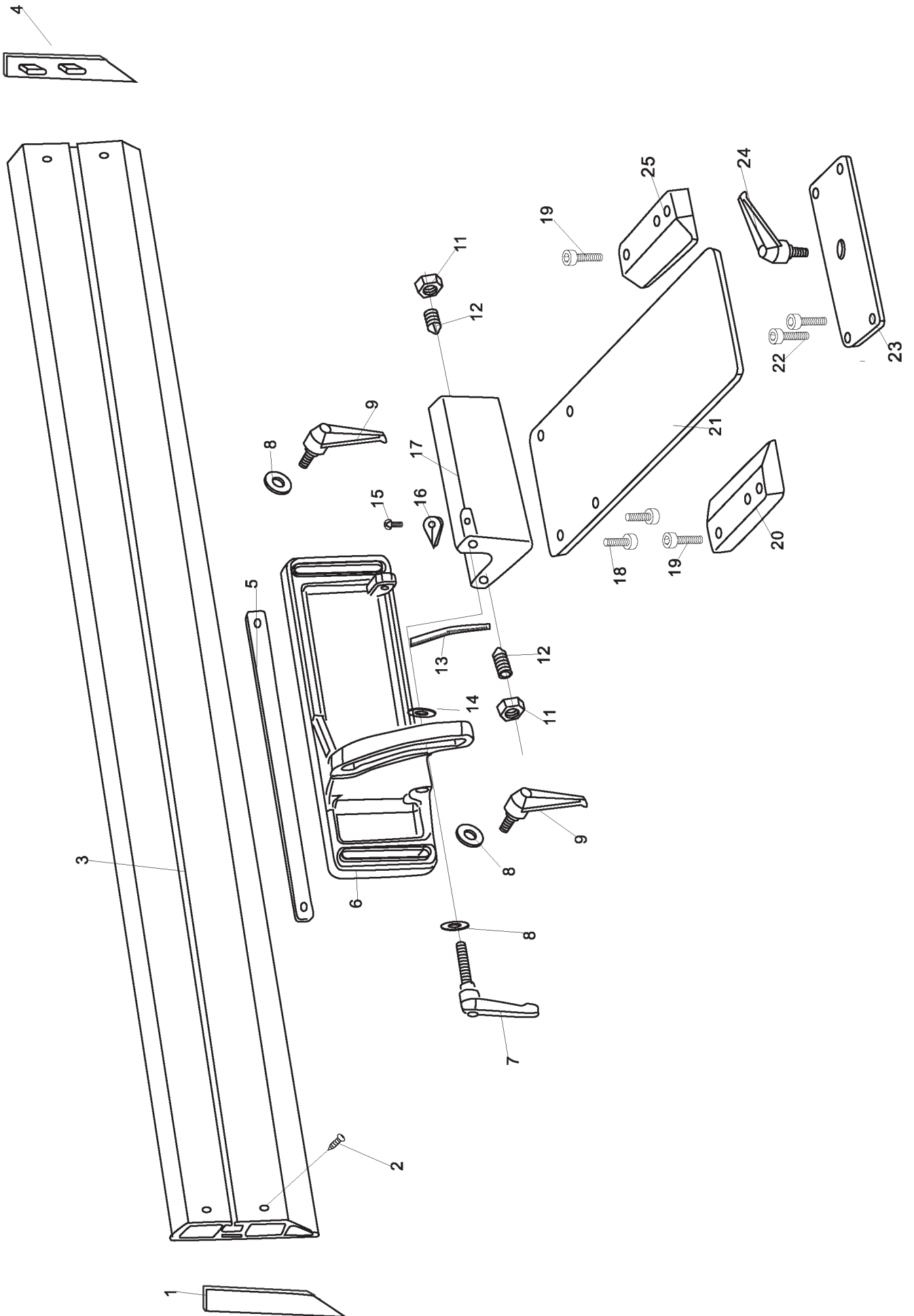

# 10. Parts List & Diagrams - cont.

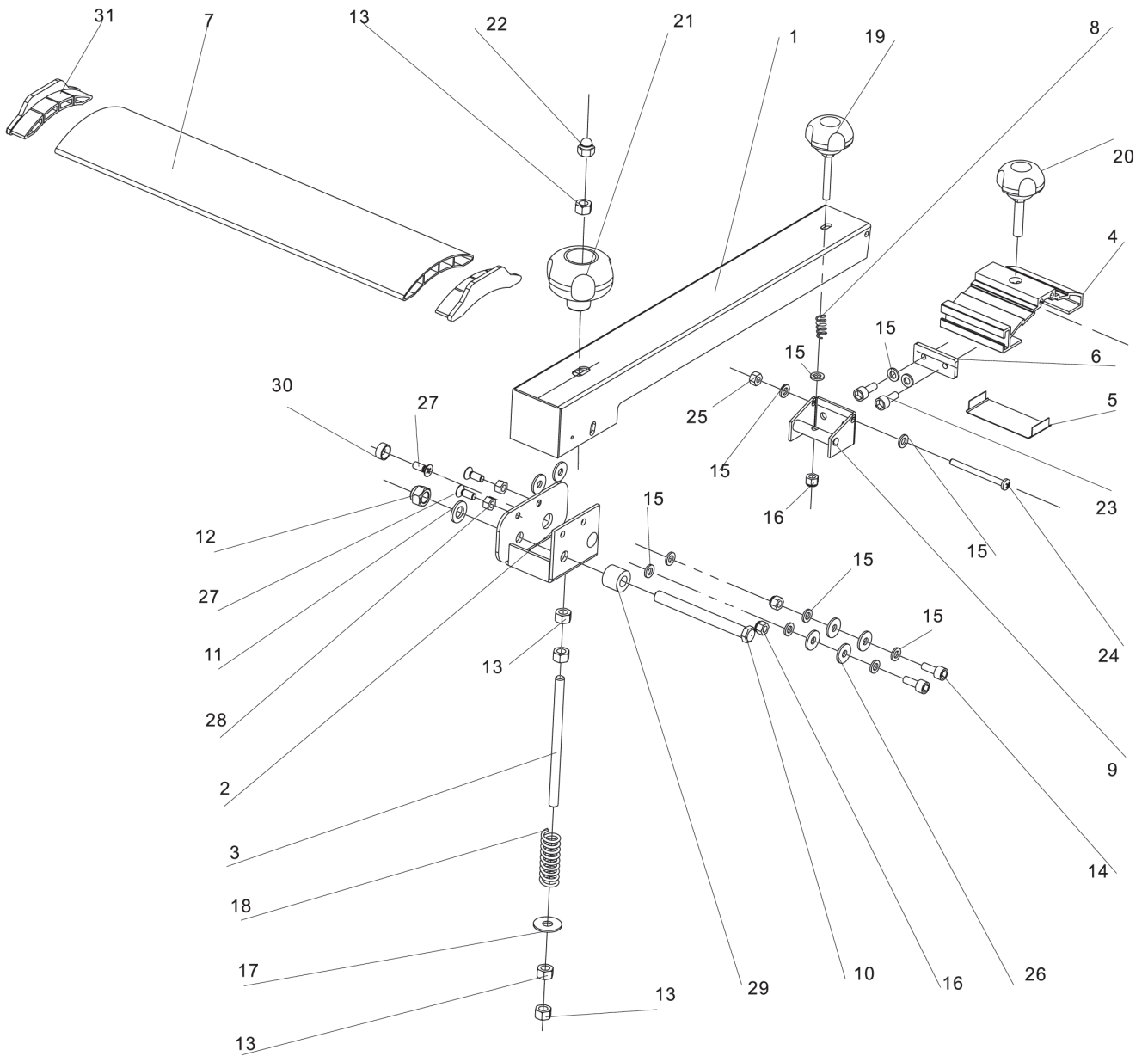

| NO. | DESCRIPTION            | Q'TY | NO. | DESCRIPTION                 | Q'TY |
|-----|------------------------|------|-----|-----------------------------|------|
| 1   | Bridge guard arm       | 1    | 17  | Flat washer 8 mm            | 1    |
| 2   | Swivel base, guard     | 1    | 18  | Spring                      | 1    |
| 3   | Rod, spring            | 1    | 19  | Star-type screw M6x35       | 1    |
| 4   | Joint, bridge guard    | 1    | 20  | Star-type screw M8x35       | 1    |
| 5   | Insert, guard          | 1    | 21  | Star-type nut               | 1    |
| 6   | Bolt guide             | 1    | 22  | Cap nut M8                  | 1    |
| 7   | Protective guard plate | 1    | 23  | Allen screw M6x10           | 2    |
| 8   | Spring                 | 1    | 24  | pan head screw M5x65        | 1    |
| 9   | Knot                   | 1    | 25  | Hex lock nut M5             | 1    |
| 10  | Hex head screw M10x100 | 1    | 26  | Spacer                      | 6    |
| 11  | Washer 10mm            | 1    | 27  | Cross sunk head screw M6x16 | 3    |
| 12  | Hex lock nut M10       | 1    | 28  | Hex lock nut M6             | 2    |
| 13  | Hex nut M8             | 5    | 29  | Spacer                      | 1    |
| 14  | Allen screw M6x20      | 2    | 30  | Spacer                      | 1    |
| 15  | Washer 6 mm            | 11   | 31  | End cap, bridge guard       | 2    |
| 16  | Hex lock nut M6        | 5    |     |                             |      |

# 10. Parts List & Diagrams - cont.

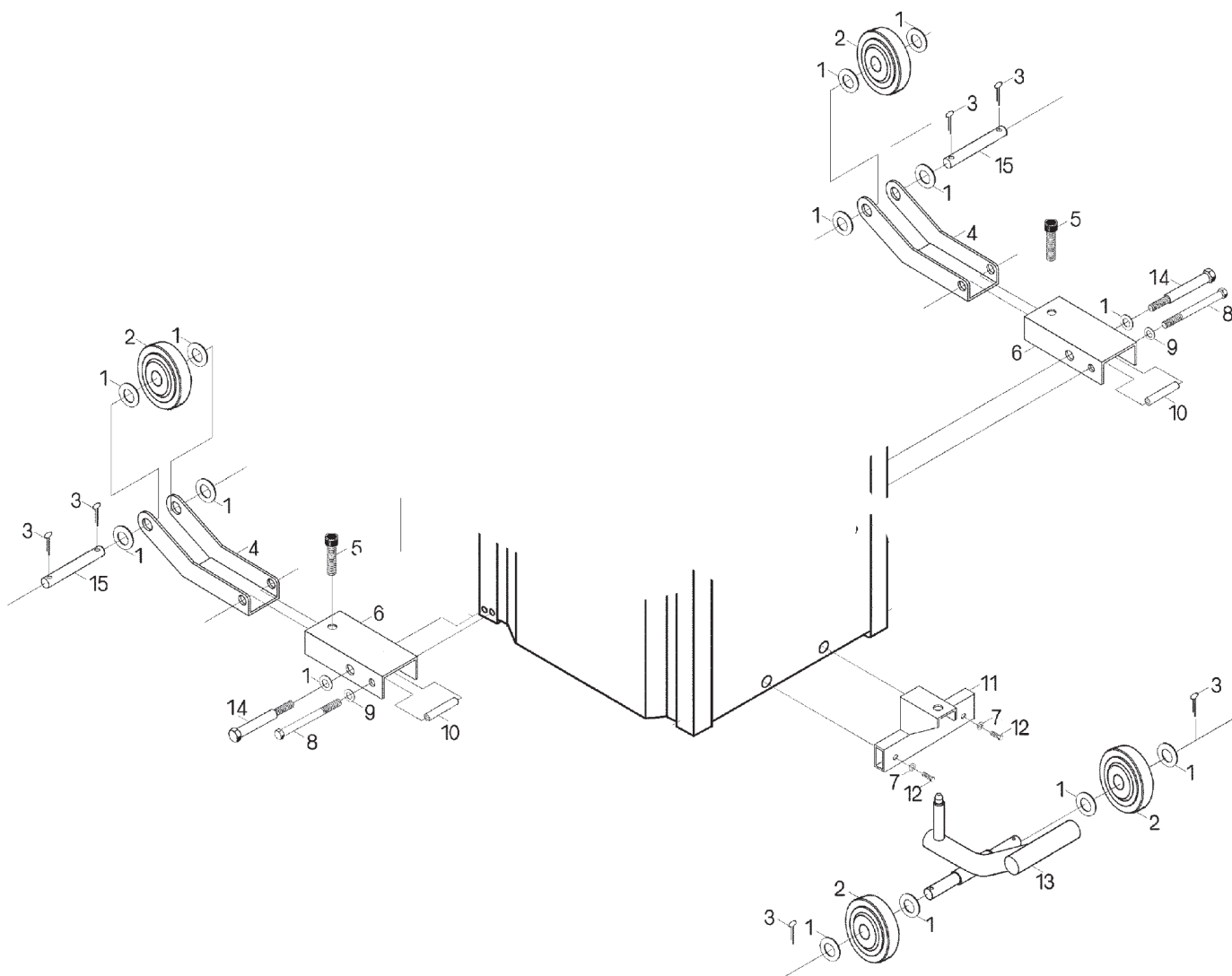

| NO. | DESCRIPTION        |
|-----|--------------------|
| 1   | Washer 16mm        |
| 2   | Castor             |
| 3   | Roll pin 4x30      |
| 4   | Bracket castor     |
| 5   | Allen screw M12x50 |
| 6   | Bracket castor     |
| 7   | Washer 10mm        |
| 8   | Hex screw M12x80   |
| 9   | Washer 12mm        |
| 10  | Bushnig bracket    |
| 11  | Support, pull rod  |
| 12  | Hex screw M10x55   |
| 12  | Pull rod           |
| 14  | Bolt, bracket      |
| 15  | Shaft, castor      |

# EU Declaration of Conformity

**Cert No: EU / PT107 / 1**

**RECORD POWER LIMITED,**

Unit B, Ireland Industrial Est.

Adelphi Way, Staveley, Chesterfield S43 3LS

declares that the machinery described:-

1. Type: **Planer Thicknesser**
2. Model No: **PT107**
3. Serial No .....

Conforms with the following directives:-

|  |  |
|--|--|
| MACHINERY DIRECTIVE                        | 2006/42/EC   |
| LOW VOLTAGE DIRECTIVE                      | 2006/95/EC   |
| ELECTROMAGNETIC<br>COMPATIBILITY DIRECTIVE | 2004/108/EC<br>EN 55014-1:2006<br>EN 61000-3-2:2006<br>EN 61000-3-3:1995+A1+A2<br>EN 55014-2:1997+A1 |

and conforms to the machinery example for which the  
EC Type-Examination Certificate No. **BM50170155, AN50170154**  
has been issued by **TUV Rheinland LGA Products GmbH**  
at: Tillystrasse 2, D90431 Nürnberg

and complies with the relevant essential health and safety requirements.

Signed..........Dated: **01/01/2013**

**Andrew Greensted**  
Managing Director







Over  
**100**  
 years

Experience • Knowledge  
 Support • Expertise

**RECORD POWER**  
 ESTABLISHED 1909®

Woodworking Machinery & Accessories

**United Kingdom**

**Record Power Ltd**

Unit B Adelphi Way, Ireland  
 Industrial Estate, Staveley,  
 Chesterfield, Derbyshire S43 3LS

Tel: 01246 561 520  
[www.recordpower.co.uk](http://www.recordpower.co.uk)

**Eire**

**Record Power Ltd**

Unit B Adelphi Way, Ireland  
 Industrial Estate, Staveley,  
 Chesterfield, Derbyshire S43 3LS

Tel: 01246 561 520  
[www.recordpower.co.uk](http://www.recordpower.co.uk)

**Australia**

**Tools 4 Industry**

Po Box 3844  
 Parramatta 2124

Tel: 1300 124 422  
 Fax: 1800 262 725  
[www.recordpower.com.au](http://www.recordpower.com.au)

**New Zealand**

**Tools 4 Industry**

Po Box 276079  
 Manukau City 2241

Tel: 0800 142 326  
 Fax: 09 2717 237  
[www.recordpower.co.nz](http://www.recordpower.co.nz)