

# RECORD POWER

ESTABLISHED 1909®

## Original Instruction Manual

# SABRE-250 10" Bandsaw

Version 3.1

May 2020

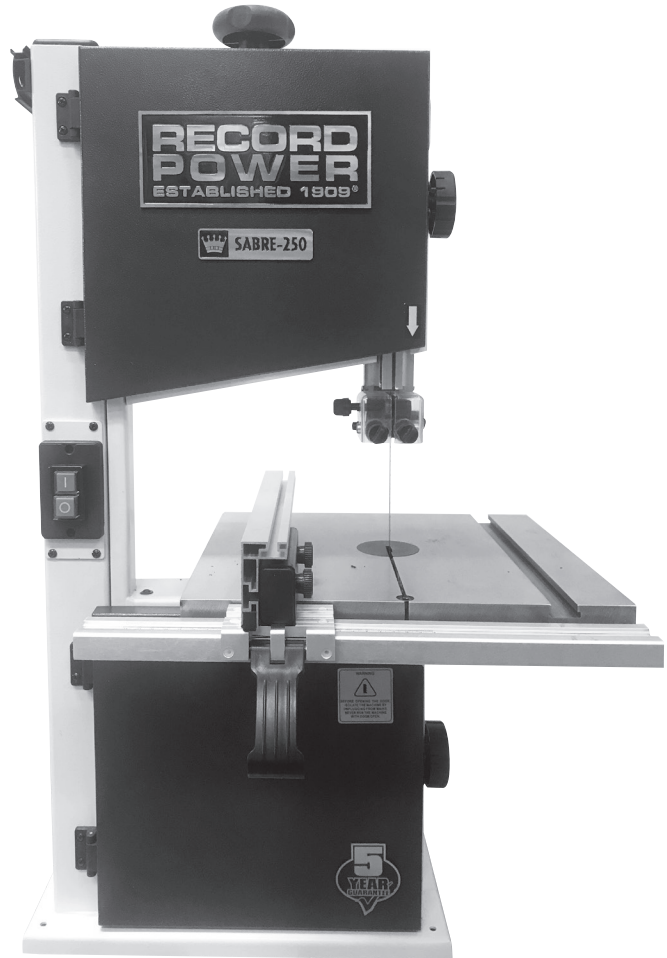

To register this product please visit  
**[www.recordpower.info](http://www.recordpower.info)**

It is important to register your product as soon as possible in order to receive efficient after sales support and be entitled to the full **5 year guarantee**. Your statutory rights are not affected.

Please see back cover for contact details.



Always wear safety glasses when using woodworking equipment.



Always read the instructions provided before using woodworking equipment.

### Important

For your safety read instructions carefully before assembling or using this product.

Save this manual for future reference.

# Contents

- 1** Explanation of Symbols
- 2** General Health and Safety Guidance
- 3** Additional Health and Safety Guidance for Bandsaws
- 4** Record Power Guarantee
- 5** Getting to Know Your Bandsaw
- 6** Specifications
- 7** Contents of the Package
- 8** Assembly
- 9** Operation and Bandsawing Practice
- 10** Maintenance
- 11** Dust Extraction
- 12** Troubleshooting
- 13** Electrical Connection and Wiring Diagram
- 14** Parts Diagrams and Lists
  - EU Declaration of Conformity

# 1. Explanation of Symbols

THE SYMBOLS AND THEIR MEANINGS SHOWN BELOW MAY BE USED THROUGHOUT THIS MANUAL. PLEASE ENSURE THAT YOU TAKE THE APPROPRIATE ACTION WHEREVER THE WARNINGS ARE USED.

## Mandatory Instructions



Read and fully understand the instruction manual before attempting to use the machine.



Indicates an instruction that requires particular attention



Wear protective eyewear



Use respiratory protective equipment



Use hearing protection



Use suitable protective footwear



Use protective work gloves

## Warning



Indicates a risk of severe personal injury or damage to the machine



Indicates a risk of severe personal injury from electrical shock



Risk of personal injury from lifting of heavy items



Indicates a risk of severe personal injury from airborne objects



Risk of fire

# 2. General Health and Safety Guidance

**Ensure that you carefully read and fully understand the instructions in this manual before assembly, installation and use of this product. Keep these instructions in a safe place for future reference.**

**WARNING:** for your own safety, do not attempt to operate this machine until it is completely assembled and installed according to these instructions.

**WARNING:** When using any machine, basic safety precautions should always be followed to reduce the risk of fire, electric shock and personal injury.

## Safe Operation

### 1. Use Personal Protective Equipment (PPE)

- The operation of any machine can result in foreign objects being thrown into your eyes, which can result in severe eye damage. Protective eyewear or other suitable eye protection or face shield should be used at all times. Everyday spectacles only have impact resistant lenses. They are not protective eyewear and do not give additional lateral protection.
- Use respiratory protective equipment (dust mask etc.) if the machining operation creates dust. Exposure to high levels of dust created by machining hardwoods, softwoods and man made composite boards can result in serious health problems. Some imported hardwoods give off highly irritating dust, which can cause a burning sensation. The use of respiratory protective equipment should not be seen as an alternative to controlling the risk of exposure at source by using adequate dust extraction equipment.
- The use of ear plugs or ear defenders is recommended when the machine is in use, particularly if the noise level exceeds 85 dB.
- Wear suitable protective gloves when handling cutting tools or blades. Gloves should NOT be worn when using the machine as they can be caught in moving parts of the machine.
- Non-slip safety footwear is recommended when using the machine and handling large work pieces.

### 2. Dress appropriately

- Do not wear loose clothing, neckties or jewellery; they can be caught in moving parts of the machine.
- Roll up long sleeves above the elbow.
- Wear protective hair covering to contain long hair.

### 3. Safety warnings

- Find and read any warning labels on the machine
- It is important that any labels bearing health and safety warnings are not removed, defaced or covered. Replacement labels can be obtained by contacting our Customer Service Department.

### 4. Familiarise yourself with the machine

- If you are not thoroughly familiar with the operation of this machine, obtain advice from your supervisor, instructor, or other qualified person or contact your retailer for information on training courses. Do not use this machine until adequate training has been undertaken.

### 5. Take care when moving or positioning the machine

- Some machines can be very heavy. Ensure the floor of the area in which the machine is to be used is capable of supporting the machine.
- The machine and its various components can be heavy. Always adopt a safe lifting technique and seek assistance when lifting heavy components. In some cases it may be necessary to use mechanical handling equipment to position the machine within the work area.
- Some machines have optional wheel kits available to allow them to be manoeuvred around the workshop as required. Care should be taken to install these according to the instructions provided.
- Due to the nature of the design of some machines the centre of gravity will be high making them unstable when moved. Extreme care should be taken when moving any machine.
- If transportation of the machine is required then all precautions relating to the installation and handling of the machine apply. In addition, ensure that any vehicles or manual handling equipment used for transportation are of adequate specification.

### 6. The machine should be level and stable at all times

- When using a leg stand or cabinet base that is designed to be fitted to the machine, always ensure that it is securely fastened to the machine using the fixings provided.
- If the machine is suitable to be used on a workbench, ensure that the workbench is well constructed and capable of withstanding the weight of the machine. The machine should always be securely fastened to the workbench with appropriate fixings.
- Where possible, floor standing machines should always be secured to the floor with fixings appropriate to the structure of the floor.
- The floor surface should be sound and level. All of the feet of the machine should make contact with the floor surface. If they do not, either re-locate the machine to a more suitable position or use packing shims between the feet and the floor surface to ensure the machine is stable.

### 7. Remove adjusting keys and wrenches

- Ensure that all adjusting wrenches and keys are removed before switching the machine 'ON'. There is a risk of severe personal injury or damage to the machine from airborne objects.

### 8. Before switching the machine 'ON'

- Clear the machine table of all objects (tools, scrap pieces etc.)
- Make sure there is no debris between the work piece and the table / work support.
- Ensure that the work piece is not pressed against, or touching the saw blade or cutting tool.
- Check all clamps, work holding devices and fences to ensure that they are secure and cannot move during machining operations.
- Plan the way that you will hold and feed the work piece for the entire machining operation.

### 9. Whilst machining

- Before starting work, watch the machine while it runs. If it makes an unfamiliar noise or vibrates excessively, switch the machine 'OFF' immediately and disconnect it from the power supply. Do not restart until finding and correcting the source of the problem.

### 10. Keep the work area clear

- Working clearances can be thought of as the distances between machines and obstacles that allow safe operation of every machine without limitation. Consider existing and anticipated machine needs, size of material to be processed through each machine and space for auxiliary stands and/or work tables. Also consider the relative position of each machine to one another for efficient material handling. Be sure to allow yourself sufficient room to safely operate your machines in any foreseeable operation.
- Cluttered work areas and benches create the risk of accidents. Keep benches clear and tidy away tools that are not in use.
- Ensure that the floor area is kept clean and clear of any dust and debris that may create trip or slip hazards.

### 11. Consider the work area environment

- Do not expose the machine to rain or damp conditions.
- Keep the work area well lit and ensure that there is artificial lighting available when there is insufficient natural light to effectively light the work area. Lighting should be bright enough to eliminate shadow and prevent eye strain.
- Do not use the machine in explosive environments eg. in the presence of flammable liquids, gases or dust.
- The presence of high levels of dust created by machining wood can present a risk of fire or explosion. Always use dust extraction equipment to minimise the risk.

### 12. Keep other persons away (and pets)

- The machine is designed to be used by one person only.
- Do not let persons, especially children, touch the machine or extension cable (if used) and keep visitors away from the work area.
- Never leave the machine running unattended. Turn the power supply off and do not leave the machine unattended until it comes to a

## 2. General Health and Safety Guidance

complete stop.

- If the work area is to be left unattended, all machinery should be switched 'OFF' and isolated from the mains power supply.

### 13. Store machines safely when not in use

- When not in use, machines should be stored in a dry place, out of reach of children. Do not allow persons unfamiliar with these instructions or with the machine to operate it.

### 14. Do not overreach

- Choose a working position that allows your body to remain balanced and feed the work piece in to the machine without overreaching.
- Keep proper footing and balance at all times.

### 15. Electrical supply

- Electrical circuits should be dedicated to each machine or large enough to handle combined motor amp loads. Power outlets should be located near each machine so that power or extension cables are not obstructing high-traffic areas. Observe local electrical guidelines for proper installation of new lighting, power outlets, or circuits.
- The machine must be connected to an earthed power supply.
- The power supply must be equipped with a circuit breaker that provides short circuit, overload and earth leakage protection.
- The voltage of the machine must correspond to the voltage of the mains power supply.
- The mains plug fitted to the machine should always match the power outlet. Do not modify the plug in any way. If a replacement plug is required it should be fitted by a competent person and of the correct type and rating for the machine.
- If you are unsure about any electrical connections always consult a qualified electrician.

### 16. Avoid unintentional starting of the machine

- Most machines are fitted with a no-volt release (NVR) switch to prevent unintentional starting. If in doubt always ensure the machine switch is in the 'OFF' position before connecting it to the power supply. This means the machine will not automatically start up after a power cut or switching on of the power supply, unless you first reset the start switch.

### 17. Outdoor use

- Your machine should not be used outdoors.

### 18. Extension cables

- Whenever possible, the use of extension cables is not recommended. If the use of an extension cable is unavoidable, then it should have a minimum core cross section of 2.5 mm<sup>2</sup> and limited to a maximum length of 3 metres.
- Extension cables should be routed away from the direct working area to prevent a trip hazard.

### 19. Guard against electric shock

- Avoid body contact with earthed or grounded surfaces such as pipes and radiators. There is an increased risk of electric shock if your body is earthed or grounded.

### 20. Always work within the machine's intended capacities

- Operator safety and machine performance are seriously adversely affected if attempts to make the machine perform beyond its limits are made.

### 21. Do not abuse the power cable

- Never pull the power cable to disconnect it from the power socket. Always use the plug.
- Keep the power cable away from heat, oil and sharp edges.
- Do not use the power cable for carrying or moving the machine.

### 22. Secure the work piece

- Ensure that the work piece is securely held before starting to machine it.
- When working within 300 mm of the machining area, always use a push stick to feed the work piece in to the blade or cutting tool. The push stick should have a minimum length of 400 mm. If the push stick becomes damaged, replace it immediately.
- Use extra supports (roller support stands etc.) for any work pieces large enough to tip when not held down to the table top.

- Do not use another person as a substitute for a table extension, or as additional support for a work piece that is longer or wider than the basic table, or to help feed, support, or pull the work piece.
- Do not attempt to machine more than one work piece at a time.
- When feeding the work piece towards the blade or cutting tool never position your hands in direct line of the cutting path. Avoid awkward operations and hand positions where a sudden slip could cause your hand or fingers to move into the machining area.

### 23. Stay alert

- Safety is a combination of operator common sense and alertness at all times when the machine is being used.
- Use all machines with extreme care and do not use the machine when you are tired or under the influence of drugs, alcohol or medication.

### 24. Use the correct tool for the job

- Do not use the machine for any purpose other than which it was designed.
- When selecting replacement cutting tools and blades, always ensure that they are designed to cut the material that you intend to use them for. If in any doubt seek further advice from the manufacturer.

### 25. Connect dust extraction equipment

- Always use dust extraction equipment. The dust extractor should be of suitable size and capacity for the machine that it is connected to and have a filtration level appropriate to the type of waste being collected. Refer to the relevant section of the manual for details of the specific dust extraction requirements for this machine.
- The dust extractor should be switched 'ON' before starting the machine that it is connected to. The dust extractor should be left running for 30 seconds after the last machining operation is complete in order to clear any residual waste from the machine.

### 26. Ensure that the machine is correctly guarded

- Never use the machine if any of the standard safety guards and equipment are removed or damaged.
- Some machines incorporate safety interlocks to prevent the machine from being used without the guards in place. Never attempt to bypass or modify the interlocks to allow the machine to be used without the guards in place.

### 27. Maintain your machine with care

- This manual gives clear instructions on installation, set up and operation of the machine and also details any routine and preventative maintenance that should be performed periodically by the user.
- Remember always to switch off and unplug the machine from the power supply before carrying out any setting up or maintenance operations.
- Follow any instructions for the maintenance of accessories and consumables.
- Do not use compressed air to clean the machine. Always use a brush to dislodge dust in places that are awkward to reach and a dust extractor to collect the waste.
- Inspect electric cables periodically and, if damaged, have them replaced by an authorised service facility or qualified electrician.
- Inspect extension cables (if used) periodically and replace if damaged.

### 28. Keep cutting tools sharp and clean

- Correctly maintained cutting tools are easier to control and less likely to bind.
- Cutting tools and blades can become hot during use. Take extreme care when handling them and always allow them to cool before changing, adjusting or sharpening them.

### 29. Disconnect the machine from the power supply

- When not in use, before servicing, changing blades etc. always disconnect the machine from the power supply.

### 30. Check for damaged parts

- Before each use of the machine, it should be carefully checked to determine that it will operate properly and perform its intended function.

## 2. General Health and Safety Guidance

- Check for alignment of moving parts, binding of moving parts, breakage of parts and any other conditions that may affect the operation of the machine.
- A guard or other part that is damaged should be properly repaired or replaced by a qualified person unless otherwise indicated in this instruction manual.
- Do not use the machine if the switch does not turn the machine 'ON' and 'OFF'.
- Have defective switches replaced by a qualified person.

### 31. Warning!

- The use of any accessory or attachment, other than those recommended in this instruction manual, or recommended by our Company may present a risk of personal injury or damage to the machine and invalidation of the warranty.

### 32. Have your machine repaired by a qualified person

- This machine complies with the relevant safety rules and standards appropriate to its type when used in accordance with these instructions and with all of the standard safety guards and equipment in place. Only qualified persons using original spare parts should carry out repairs. Failure to do this may result in considerable danger to the user and invalidation of warranty.

### 33. Caution! Motor may become hot during use

- It is normal for motors on some machines to become hot to the touch during use. Avoid touching the motor directly when in use.

## 3. Additional Health and Safety Guidance for Bandsaws

### Safe Operation

#### 1. Familiarise yourself with the machine

- Machining operations using bandsaws have a history of serious accidents. Most result from contact with the moving blade while presenting material to the blade or moving it from the table. Other minor accidents can occur whilst setting, cleaning, adjusting or maintaining the machine.
- The machine is designed for cutting wood and composite board (plywood, MDF etc.). Certain plastics can also be cut using a suitable blade.

#### 2. Before switching the machine 'ON'

- Ensure that the blade is correctly tensioned and aligned on the band wheels and the blade guides are correctly adjusted.
- Ensure that the teeth of the blade are pointing downwards.
- Check the condition of the blade to ensure that no teeth are missing, damaged or deformed and the blade is not cracked or split. If any of these conditions apply, replace the blade immediately.
- Ensure that the saw blade type and width are suitable for the material to be cut.
- Check that the blade width is within the minimum and maximum permitted on the machine and that the thickness of the blade is suitable for the diameter of the wheel.
- Some machines have more than one cutting speed. For most wood cutting applications the faster of the speeds should be used.
- Check the condition of the table insert. Replace it immediately if it is damaged or showing signs of wear.
- Adjust the guard as close as possible to the work piece being cut.
- Check that access doors are fully closed and that the latches are secure.

### 3. Whilst machining

- Never apply sideways pressure to the blade as this may cause the blade to break.
- Care must be taken when cutting wood with knots, nails or cracks in it and / or dirt on it, as these can cause the blade to get stuck. If this happens, switch the machine 'OFF' immediately and follow the procedure detailed in the manual to remove the blade from the work piece.
- If cutting cylindrical timber use a suitable jig to prevent twisting of the work piece.

4. This machine falls under the scope of the 'Health and Safety at Work etc. Act 1974', and the 'Provision & Use of Work Equipment Regulations 1998'. In addition the elimination or control of risks from wood dust is included in the above regulations and the 'Control of Substances Hazardous to Health (COSHH) Regulations 2002'. We recommend that you study and follow these regulations.

Further guidance can be found in the 'Safety in the use of narrow bandsaws – Woodworking sheet No.31' and the 'Safe use of woodworking machinery' code of practice booklet (L114) published by Health and Safety Executive and available from their website [www.hse.gov.uk](http://www.hse.gov.uk).

# 4. Record Power Guarantee

“**Products**” means the Products sold by Record Power subject to these terms and conditions;

“**Record Power**” is Record Power Limited, whose company registration number is 4804158 and registered office address is Centenary House, 11 Midland Way, Barlborough Links, Chesterfield, Derbyshire, S43 4XA and sells through a network of Authorised Dealers;

“**Authorised Distributor**” is the nominated importer for your region who will generally sell through a network of Authorised Dealers. Details of Authorised Distributors for specific countries can be found in the Product manual or at [www.recordpower.info](http://www.recordpower.info);

“**Authorised Dealer**” is a retailer or business authorised to sell Record Power Products to end users.

## 1 Guarantee

- 1.1 Record Power guarantees that for a period of 5 years from the date of purchase the components of qualifying Products (see clauses 1.2.1 to 1.2.9) will be free from defects caused by faulty construction or manufacture.
- 1.2 During this period Record Power, its Authorised Distributor or Authorised Dealer will repair or replace free of charge any parts which are proved to be faulty in accordance with paragraphs 1.1 above provided that:
  - 1.2.1 you follow the claims procedure set out in clause 2 below;
  - 1.2.2 Record Power, our Authorised Distributor or Authorised Dealer are given a reasonable opportunity after receiving notice of the claim to examine the Product;
  - 1.2.3 if asked to do so by Record Power, its Authorised Distributor or Authorised Dealer, you return the Product, at your own cost, to Record Power’s premises or other approved premises such as those of the Authorised Distributor or supplying Authorised Dealer, for the examination to take place;
  - 1.2.4 the fault in question is not caused by industrial use, accidental damage, fair wear and tear, wilful damage, neglect, incorrect electrical connection, abnormal working conditions, failure to follow our instructions, misuse, or alteration or repair of the Product without our approval;
  - 1.2.5 the Product has been used in a domestic environment only;
  - 1.2.6 the fault does not relate to consumable Products such as blades, bearings, drive belts or other wearing parts which can reasonably be expected to wear at different rates depending on usage (for full details contact Record Power or your local Authorised Distributor);
  - 1.2.7 the Product has not been used for hire purposes, by you or by a previous owner;
  - 1.2.8 the Product has been purchased by you as the guarantee is not transferable from a private sale.
  - 1.2.9 where the Product has been purchased from a retailer, the 5 year guarantee is transferable and begins on the date of the first purchase of the Product and in the event of a claim under this guarantee proof of the original purchase date will be required to validate the warranty period.

## 2 Claims Procedure

- 2.1 In the first instance please contact the Authorised Dealer who supplied the Product to you. In our experience many initial problems with machines that are thought to be due to faulty parts are actually solved by correct setting up or adjustment of the machines. A good Authorised Dealer should be able to resolve the majority of these issues much more quickly than processing a claim under the guarantee.
- 2.2 Any damage to the Product resulting in a potential claim under the guarantee must be reported to the Authorised Dealer from which it was purchased within 48 hours of receipt.
- 2.3 If the Authorised Dealer who supplied the Product to you has been unable to satisfy your query, any claim made under this Guarantee should be made directly to Record Power or its Authorised Distributor (for details of the Authorised Distributor in your country please see your Product manual or check [www.recordpower.info](http://www.recordpower.info) for details). The claim itself should be made in a letter setting out the date and place of purchase, and giving a brief explanation of the problem which has led to the claim. This letter should then be sent with proof of the purchase date (preferably a receipt) to Record Power or its Authorised Distributor. If you include a phone number or email address this will help to speed up your claim.
- 2.4 Please note that it is essential that the letter of claim reaches Record Power or its Authorised Distributor on the last day of this Guarantee at the latest. Late claims will not be considered.

## 3 Limitation of Liability

- 3.1 We only supply Products for domestic and private use. You agree not to use the Product for any commercial, business or re-sale purposes and we have no liability to you for any loss of profit, loss of business, business interruption or loss of business opportunity.
- 3.2 This Guarantee does not confer any rights other than those expressly set out above and does not cover any claims for consequential loss or damage. This Guarantee is offered as an extra benefit and does not affect your statutory rights as a consumer.

## 4 Notice

This Guarantee applies to all Products purchased from an Authorised Dealer of Record Power within the United Kingdom of Great Britain and Northern Ireland. Terms of Guarantee may vary in other countries – please check with the Authorised Distributor in your country (details of the Authorised Distributor for your country can be found in the manual or at [www.recordpower.info](http://www.recordpower.info)).

## 5. Getting to Know Your Bandsaw

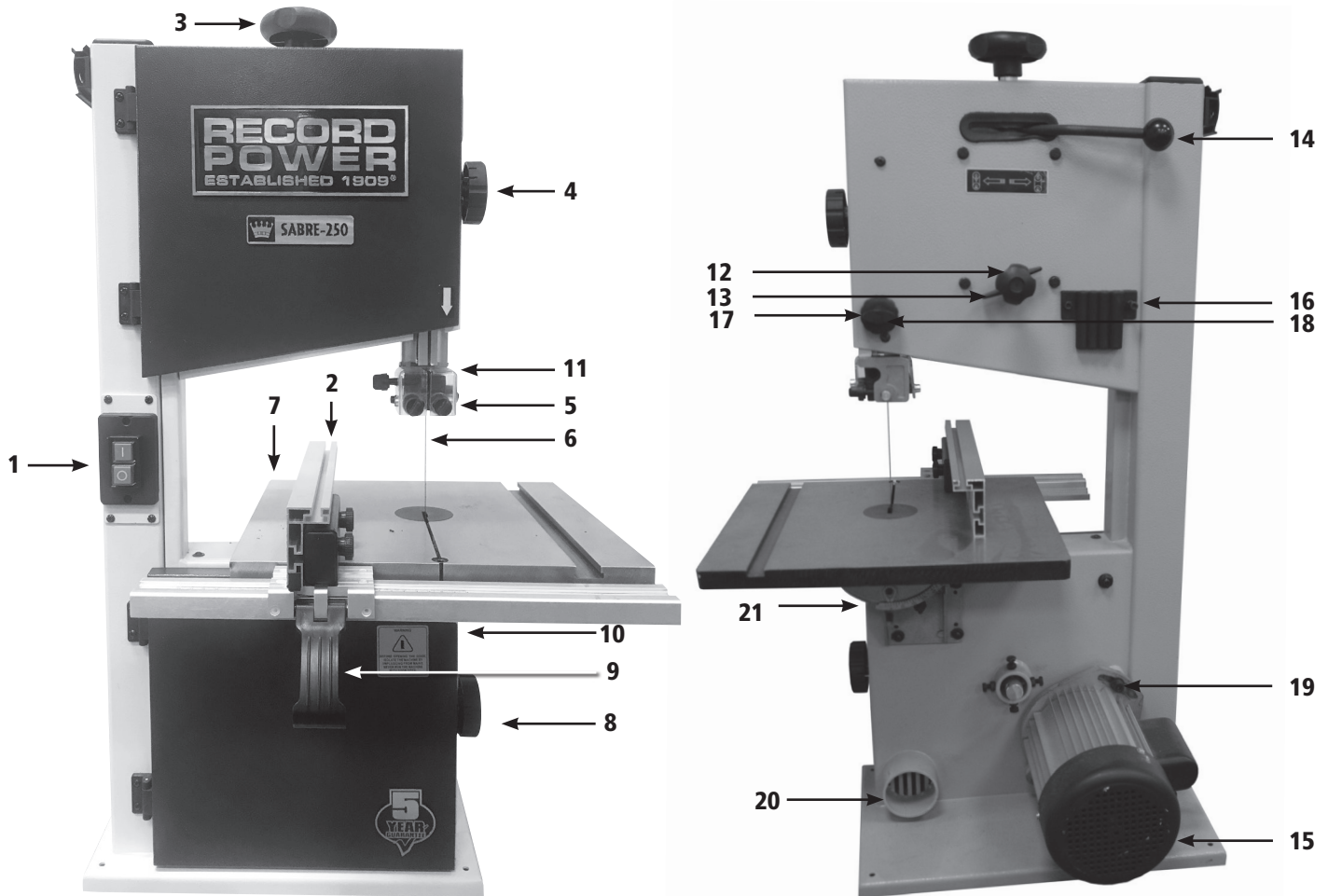

- |    |                          |    |                                |
|----|--------------------------|----|--------------------------------|
| 1  | On / off switch          | 12 | Blade tracking knob            |
| 2  | Rip fence                | 13 | Blade tracking lock            |
| 3  | Blade tensioning knob    | 14 | Cam tension lever              |
| 4  | Upper door knob          | 15 | Motor                          |
| 5  | Upper blade guides       | 16 | Tool holder                    |
| 6  | Blade                    | 17 | Blade guide position knob      |
| 7  | Table                    | 18 | Blade guide position lock      |
| 8  | Lower door knob          | 19 | Drive belt tension release nut |
| 9  | Rip fence locking handle | 20 | Dust extraction port           |
| 10 | Lower blade guides       | 21 | Trunnion                       |
| 11 | Protective cover         |    |                                |

## 6. Specifications

**Maximum depth of cut:** 127 mm  
**Throat depth:** 245 mm  
**Table size:** 350 x 318 mm  
**Table height from base:** 368 mm  
**Motor input P1:** 550 W  
**Motor output P2:** 370 W

**Voltage:** 230 v  
**Frequency:** 50Hz  
**Full load current:** 2.4A  
**Short circuit rating:** 1 kA  
**Motor speed:** 1400 rpm  
**Blade length:** 70.5"

**Blade width capacity:** 1/4" (6 mm) - 1/2" (12 mm)  
**Blade speed:** 460 m / minute and 1000 m / minute  
**Extraction port internal diameter:** 58.8 mm  
**Extraction port external diameter:** 64.5 mm  
**Weight:** 35 kg  
**Size:** H865 x W525 x D470 mm

**Sound power level:** <100dBA  
**Sound pressure level:** <90dBA  
**Main document number:** BS250B

} Associated uncertainty K=4 dB measurement made in accordance with EN ISO 3746:2010

The figures quoted are emission levels and are not necessarily safe working levels. Whilst there is a correlation between the emission and exposure levels, this cannot be used reliably to determine whether or not further precautions are required. Factors that influence the actual level of exposure of the workforce include the characteristics of the work room and the other sources of noise, etc., i.e. the number of machines and other adjacent processes. Also, the permissible exposure level can vary from country to country. This information, however, will enable the user of the machine to make a better evaluation of the hazard and risk.



# 7. Contents of the Package

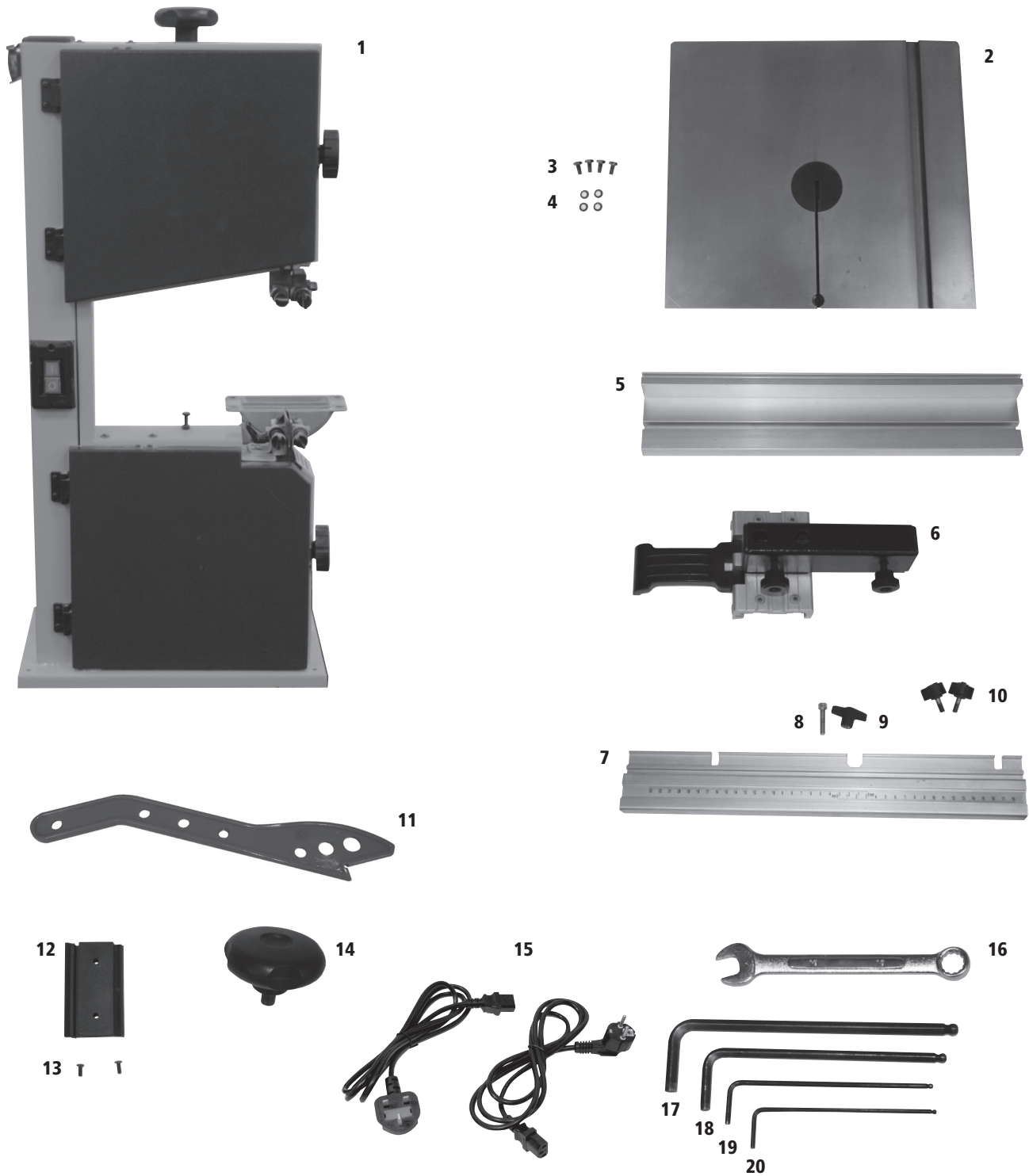

- |           |                          |   |           |                             |   |
|-----------|--------------------------|---|-----------|-----------------------------|---|
| <b>1</b>  | SABRE-250 Bandsaw        | 1 | <b>11</b> | Push stick                  | 1 |
| <b>2</b>  | Table                    | 1 | <b>12</b> | Rip fence holder            | 1 |
| <b>3</b>  | M6 Hex bolts             | 4 | <b>13</b> | Screws                      | 2 |
| <b>4</b>  | Washers                  | 4 | <b>14</b> | Blade tensioning knob       | 1 |
| <b>5</b>  | Rip fence                | 1 | <b>15</b> | UK and European power cords | 1 |
| <b>6</b>  | Rip fence mount          | 1 | <b>16</b> | 10 mm wrench                | 1 |
| <b>7</b>  | Fence rail               | 1 | <b>17</b> | 6 mm hex wrench             | 1 |
| <b>8</b>  | Table levelling bolt     | 1 | <b>18</b> | 5 mm hex wrench             | 1 |
| <b>9</b>  | Table levelling wing nut | 1 | <b>19</b> | 3 mm hex wrench             | 1 |
| <b>10</b> | Fence rail star knob     | 2 | <b>20</b> | 2.5 mm hex wrench           | 1 |

# 8. Assembly

Mount the table in place on the trunnion. Do this from the rear of the machine for easy access of the pre-installed blade through the slot in the table. The table trunnion has 4 holes as shown in **Fig 8.1** and the underside of the table has 4 corresponding threaded holes as shown in **Fig 8.2**.

Attach the table to the trunnion. To attach, use the 4 supplied M6 hex bolts using the 10 mm wrench, followed by the 4 washers. For accessibility, begin by placing 2 hex bolts and washers into the 2 holes nearest to the mitre slot. Then, use the trunnion ratchet handle as shown in **Fig 8.4**, raise the angle of the table for easy access and insert the 2 remaining bolts and washers. Once in place, return the table to the horizontal position as shown in **Fig 8.3**.

**Note: Do not fully tighten fixings until the table is set at the correct angle.**



### Aligning the Table to the Blade

For accurate cutting the table must be parallel to the bandsaw blade. Place a straight edge along the blade as shown in **Fig 8.3** then measure the distance between the straight edge and the mitre fence slot in the table as shown. When the distances are equal at the front and back of the mitre slot the bolts can be tightened fully.

Once tightened, check the alignment and re-adjust if necessary.

### Positioning the Table at 90° to the Blade

Loosen the trunnion ratchet handle shown in **Fig 8.4** to tilt the table and allow required adjustment.

Ensure that the table is at 90° to the blade by using a square as shown in **Fig 8.5**.

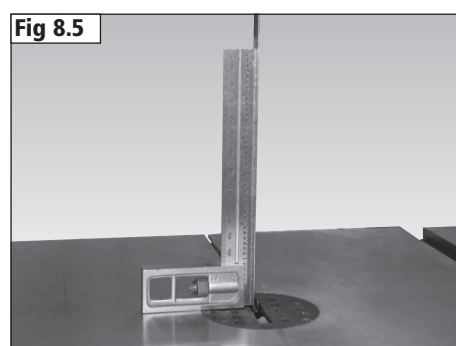
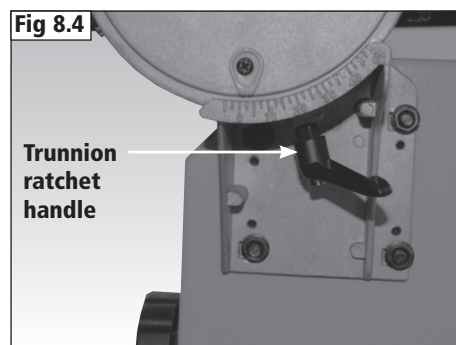
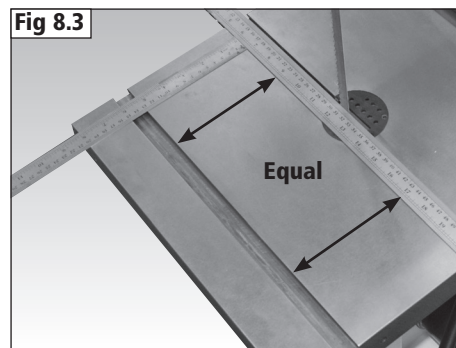
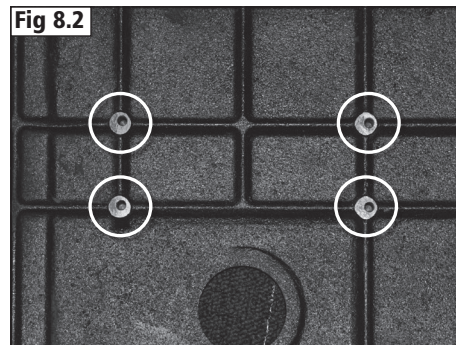
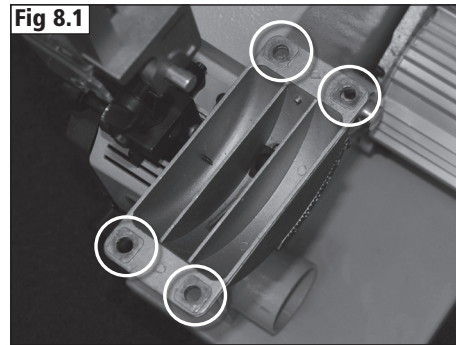

# 8. Assembly

Once the table is at 90° to the blade with a square, the angle scale pointer can now be adjusted to point to 0° as shown in **Fig 8.6** using a Phillips screwdriver.

Next, ensure that the table sits on the M6 x 35 table stop hex bolt located on the underside of the table **Fig 8.7**. This bolt is factory set and acts as a table stop to ensure the table returns to the correct position when it is required to be at 90° to the blade. If necessary, adjust the table stop bolt with a 10 mm wrench to ensure that the bolt is in the correct position.

### Table Levelling Bolt Assembly

To keep the two sides of the table level to each other, use the supplied table levelling wing nut and bolt. Insert the bolt through the hole located at the front of the table, and secure in place from the underside of the table using the wing nut as shown in **Fig 8.8**.



**The levelling bolt should be kept in place at all times, and only removed when changing the bandsaw blade.**

### Installation of Fence Rail

Position the Fence Rail onto the front of the table by aligning the right-hand side to the edge of the table. Slide the fence rail in position as shown in **Fig 8.9**, then securely fasten using the two fence rail star knobs into the holes on the underside of the table at both ends **Fig 8.10**. The centre cut-out is used to allow easy access to the table levelling bolt and wing nut.

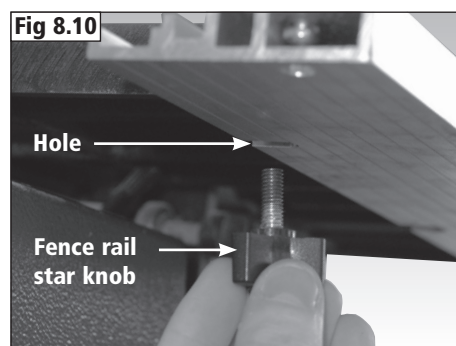
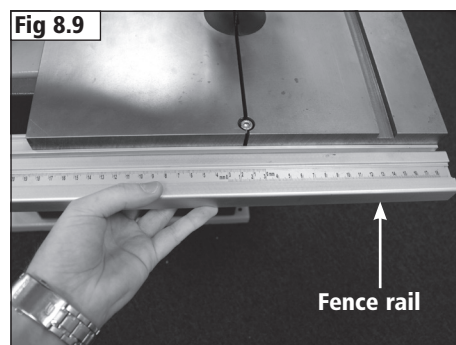
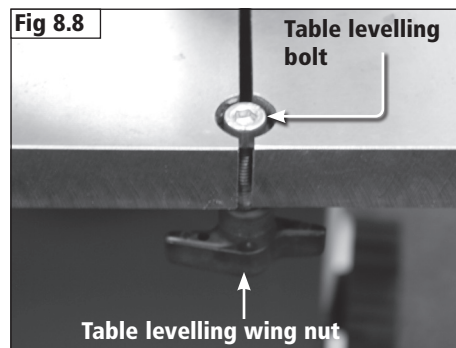
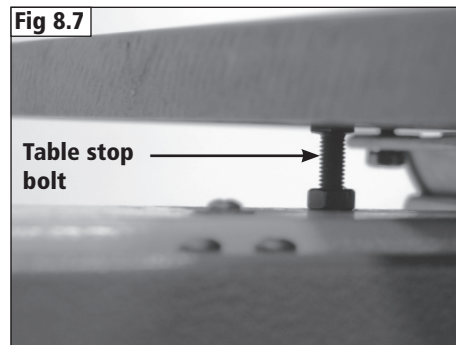
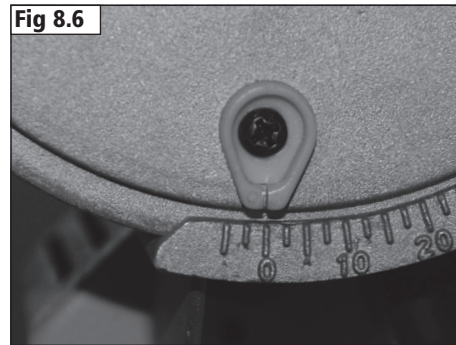

# 8. Assembly

## Installation of Rip Fence Mount

Slide the rip fence mount onto the fence rail. Ensure that the fence mount locking handle is in the released, upright position, to allow it to be fitted onto the top of the fence rail as shown in **Fig 8.11**. Once in place, move the fence mount locking handle down into the locked position on the fence rail to secure in place.

## Mounting the Rip Fence to the Fence Mount

The rip fence attaches to the fence mount by sliding the fence onto the T-bar located on the side of the fence mount, **Fig 8.12**. There are two 'T' slots located to the rear of the rip fence that the T-bar will slide into. The 2 'T' slots allow the fence to be positioned in both a horizontal and vertical position, as shown in **Fig 8.13** and **Fig 8.14**.

To fit, loosen the two nuts on the side of the rip fence mount to allow the rip fence to easily be attached. Once in place, secure the fence to the fence mount by tightening the same 2 nuts.

## Mounting the Rip Fence to the Right-hand Side of the Blade

To support work when cutting with the table tilted, the rip fence can be placed to the right-hand side of the blade.

Remove the rip fence from the rip fence mount. Fully unscrew the two nuts holding the T-bar to the fence mount and remove from the fence mount. Then, re-fit to the opposite side of the fence mount, as shown in **Fig 8.12**.

Re-fit the rip fence to the mount as previously described.

## Aligning the Fence with the Blade

For accurate cutting the rip fence must be parallel to the blade. This can be achieved by ensuring the fence is parallel with the mitre slot, as shown in **Fig 8.15**.

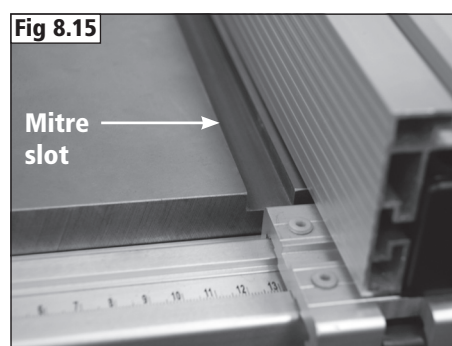
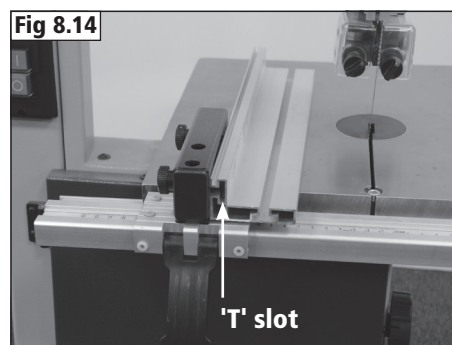
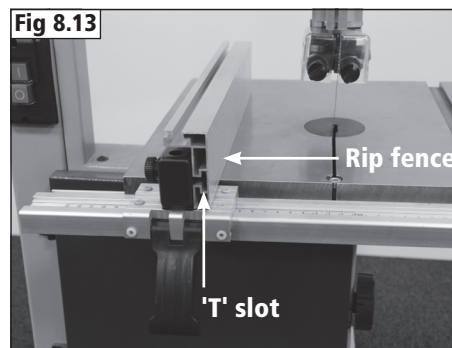
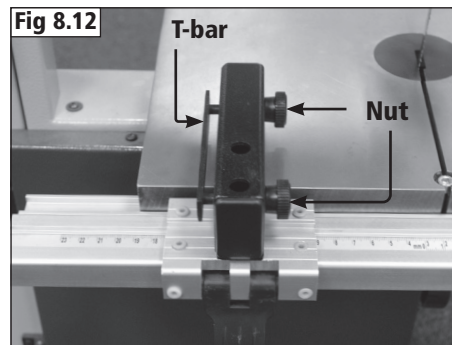
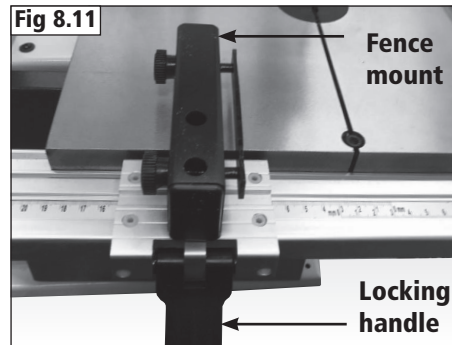

# 8. Assembly

## Adjusting the Rip Fence

To adjust the angle and verticality of the rip fence in relation to the table, use the 3 mm hex wrench and adjust the 4 plastic hex screws on top of the fence mount by rotating clockwise and anti-clockwise, **Fig 8.16**.

To adjust the sliding distance between the rip fence mount and fence rail when the locking handle is released, use the 3 mm hex wrench and adjust two plastic hex screws on the side of the fence mount by rotating clockwise and anticlockwise, **Fig 8.16**.

To ensure that the rip fence is correctly parallel to the table mitre slot and blade, adjust the 2 plastic hex screws, as shown in **Fig 8.17**.

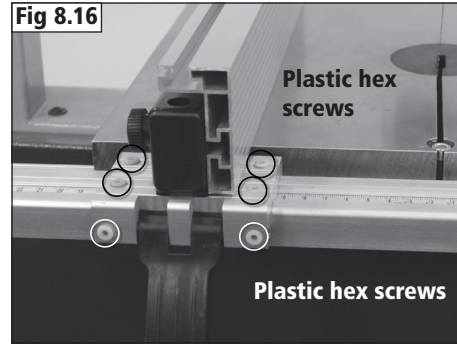

## Fitting the Blade Tensioning Knob

Place the blade tension knob onto the tension rod as shown in **Fig 8.18**.

## Fence Holder Assembly

Install the Fence Holder to the top, left side of the column on the bandsaw using the 2 supplied flat head screws **Fig 8.19**.



**The wider, double lip should be positioned at the top and the single lip positioned at the bottom.**

Fit the rip fence to the fence holder, as shown in **Fig 8.20**, and secure in place using the locking handle.

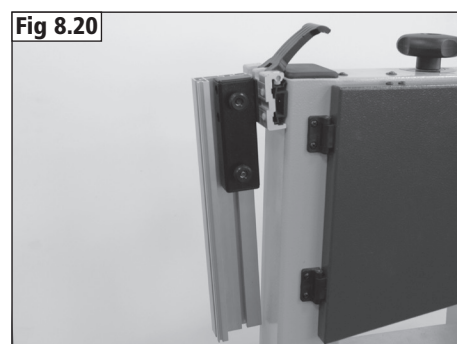
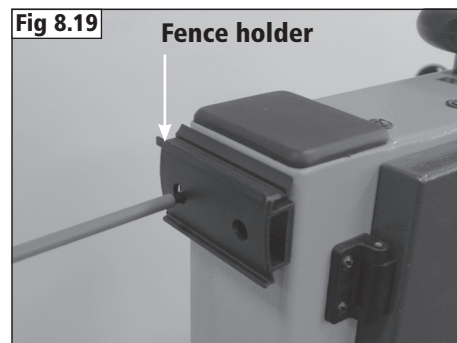
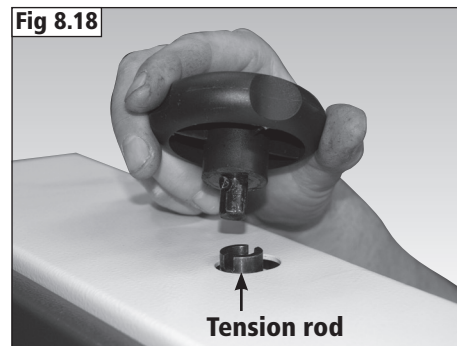
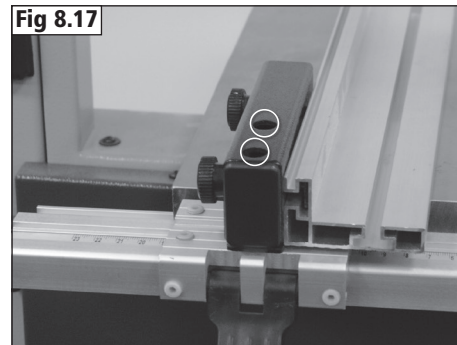

# 8. Assembly

## Fitting the Tool Holder

Secure the tool holder to the rear of the bandsaw spine as shown in **Fig 8.21** using the 2 M5 x 10 mounting screws.

The tool holder is used for storing the hex wrenches supplied with the machine as shown in **Fig 8.22**.

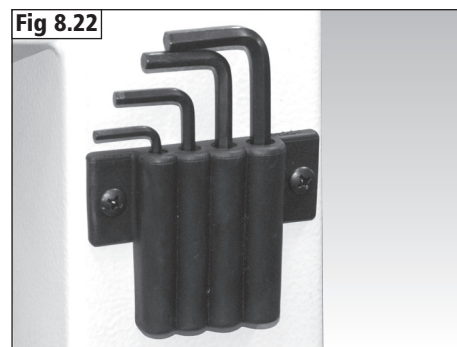
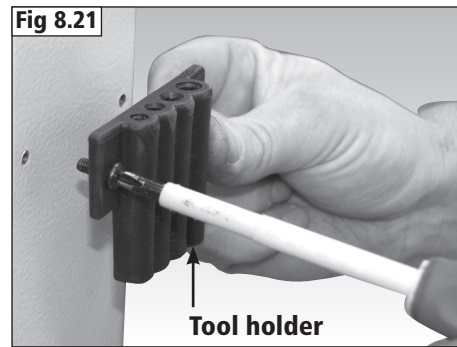

# 9. Operation and Bandsawing Practice



**Caution:** Before carrying out any adjustments or maintenance ensure that the machine is isolated and disconnected from the electricity supply.

## Changing the Bandsaw Blade

Open the upper and lower band wheel box doors.

First, if necessary, raise the fence locking handle into the released position. Next, remove the rip fence assembly from the fence rail. Remove the 2 fence rail star knobs from either side of the fence as shown in **Fig 9.1** and remove the fence rail. Next, remove the table levelling wing nut from the levelling bolt located on the underside of the table as shown in **Fig 9.2** to allow the blade to be passed through the blade slot.

Move the cam blade tension lever into the released position, as shown in **Fig 9.3**.

Wearing protective gloves, carefully remove the blade by pulling it forwards and out from the table slot as shown in **Fig 9.4**. Ensure the left-hand side of the blade is brought through the gap in the spine blade cover as shown in **Fig 9.5**.

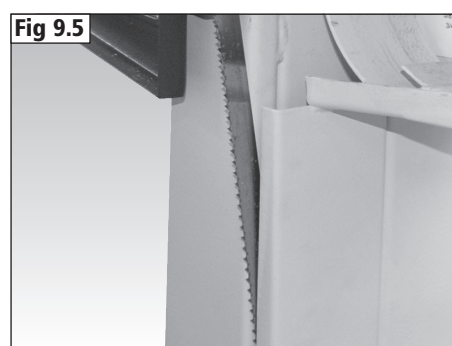
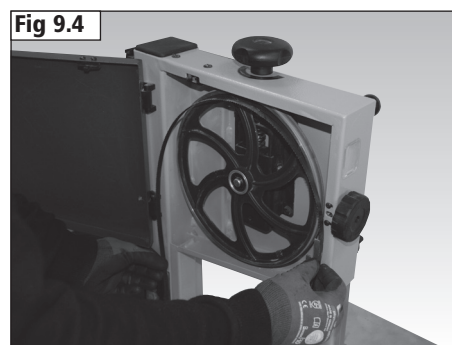
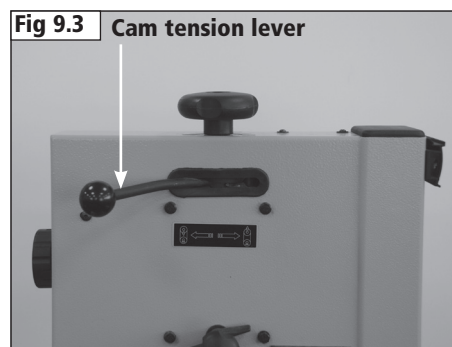
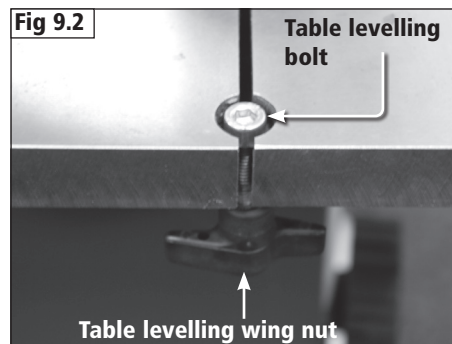
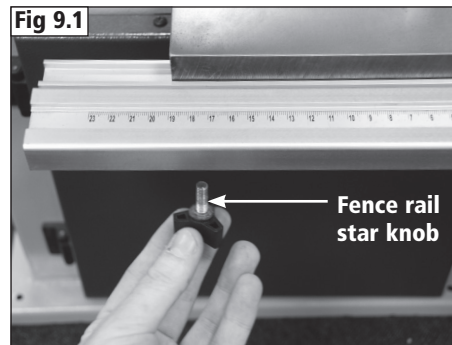

# 9. Operation and Bandsawing Practice

Fit the new blade to the bandsaw, ensuring the teeth of the blade point downwards and towards the front of the machine, **Fig 9.6**.

**Note: If the new blade is the same size and type as the old blade, the blade tension and guide positions may not need adjusting.**

### Tensioning the Bandsaw Blade

Re-engage the cam tension lever and if necessary, adjust the tension knob to apply the correct tension to the blade.

To check the tension of the blade, set the blade guides to their highest position and apply a reasonable amount of pressure using a push stick. A correctly tensioned blade will move approximately 4 mm as shown in **Fig 9.7**. Do not overtighten the blade as shown in **Fig 9.7** as this could damage it.

Bandsaw blade tension can be subject to personal preferences and opinions vary on the best ways to measure the tension and of what the correct tension should be. If the blade is cutting accurately then this is the best indication that the tension (and overall machine setup) is correct. If adjusting the blade tension does not correct a poorly performing blade, this could indicate that the blade needs replacing.

If the machine is not in use for long periods, slacken the tension to avoid placing unnecessary pressure on the blade and the bandsaw itself.

### Tracking the Bandsaw Blade

A correctly tracked blade will sit centrally on the band wheels as shown in **Fig 9.8**.

To track the bandsaw blade, loosen the blade tracking lock located at the rear of the machine and adjust the tracking with the blade tracking knob, as shown in **Fig 9.9**. Turn the tracking knob clockwise to move the blade towards the back of the band wheel and anti-clockwise to move it towards the front. Rotate the band wheels manually by hand several times, for the tracking adjustment to take effect. This will help moving the blade into the correct position. Once the tracking is set correctly re-tighten the blade tracking lock.

To aid tracking there is an inspection window on the side of the upper band wheel box as shown in **Fig 9.10** which allows the blade position to be seen.

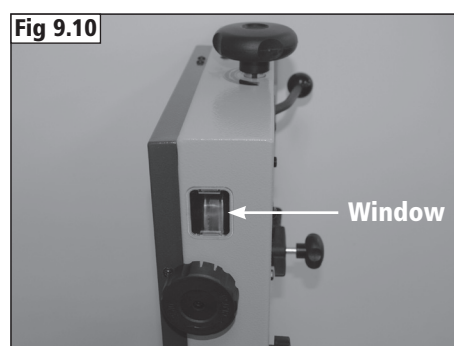
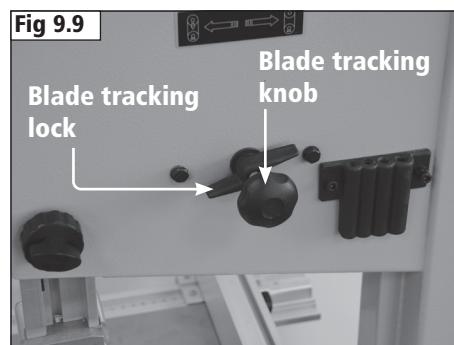
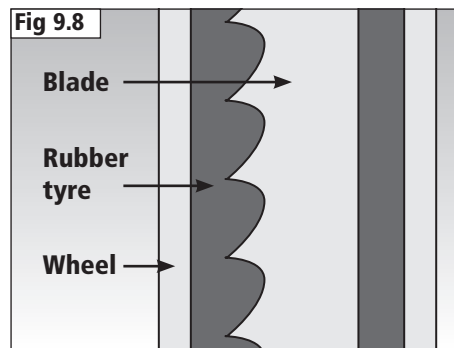
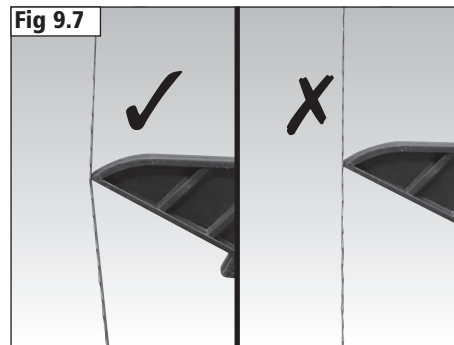
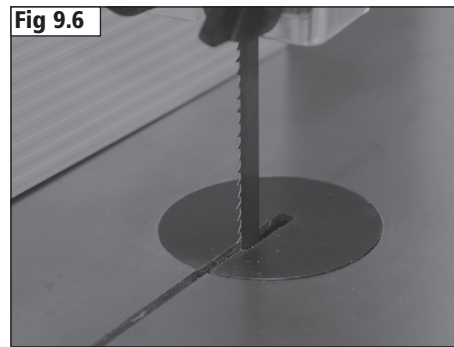



# 9. Operation and Bandsawing Practice

## Setting the Blade Guides

Once the blade is installed, tensioned and tracked the guides must be set correctly around it.

There are 2 sets of guides on the bandsaw, one above the table and one below. Both sets feature a guide on both sides of the blade and to the rear of the blade. All guides are spring-loaded for easy adjustment.

The side guides should be positioned so they are just behind the blade gullet. This will ensure the teeth do not catch on the guides during operation **Fig 9.11**.

In addition, the side guides should also be positioned as close to the blade as possible but without touching the blade. The guides should not be touching the blade when the machine is running and not under load as constant contact will reduce the life span of the blade, See **Fig 9.12**.

The rear guide must also be placed as close as possible to the blade but not be touching it, see **Fig 9.13**.



**Important: When positioning the side guides behind the blade gullet take into account the possible backwards movement of the blade during cutting to ensure that the side guides do not protrude past the gullet. This would damage the set and the blade would need to be replaced.**

## Adjusting the Upper Blade Guides

Loosen the side guide lock knobs by rotating anti-clockwise, shown in **Fig 9.14**. Position the guides correctly by moving the guide shafts. Move the shafts by applying or releasing pressure through the access holes on either side of the protective cover, then re-tighten the side guide lock knobs, as shown in **Fig 9.15**.

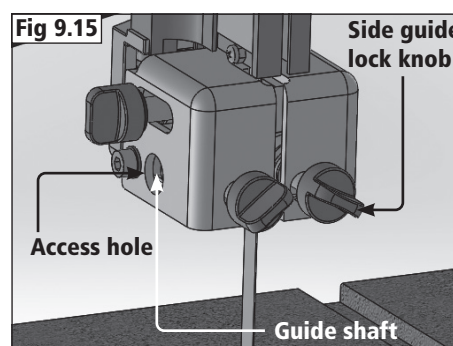
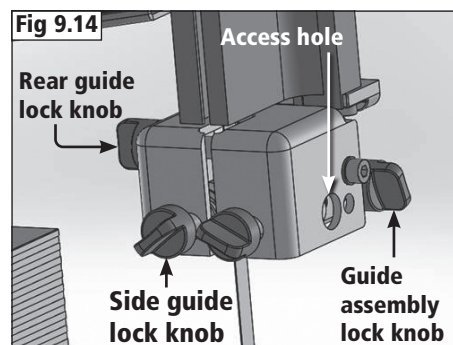
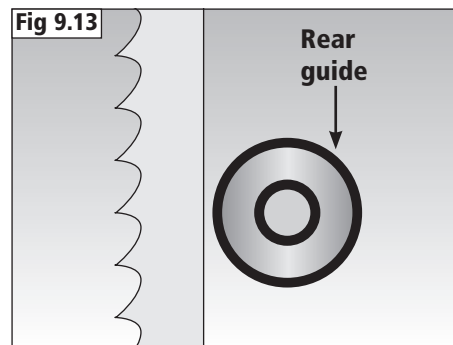
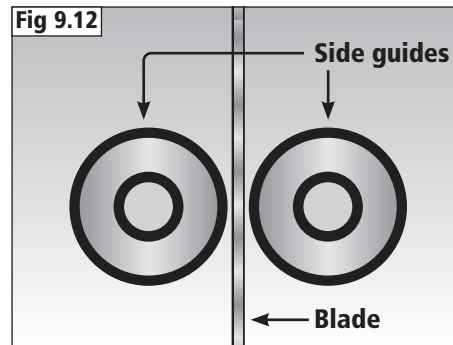
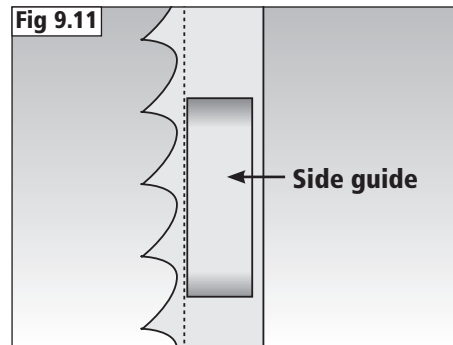

# 9. Operation and Bandsawing Practice

The rear guide must now be set in the correct position. Loosen the rear guide lock knob and re-position the guide, **Fig 9.16**.

### Adjusting the Lower Blade Guides

The lower guides are set in the same way as the upper guides. The guide assembly differs to the upper assembly as there is a ratchet handle that must be loosened to allow movement of the guide assembly, see **Fig 9.17**.

### Setting the Height of the Upper Blade Guides

The upper guide assembly should be set as low as possible for the cut being made to give maximum support to the blade and aid in accurate cutting.

To move the guide assembly, loosen the blade guide lock at the rear of the machine as shown in **Fig 9.18** and rotate the blade guide position knob to raise or lower the assembly to the required height. Once in position, re-tighten the blade guide lock to ensure that the guide assembly remains in a fixed position.

The assembly must allow the workpiece to pass beneath it as shown in **Fig 9.19**.

### Turning the Bandsaw On and Off

The bandsaw is fitted with colour coded On and Off switches.

To turn the machine on press the green button marked '1'.

To turn the machine off press the red button marked '0'.

See **Fig 9.20**.

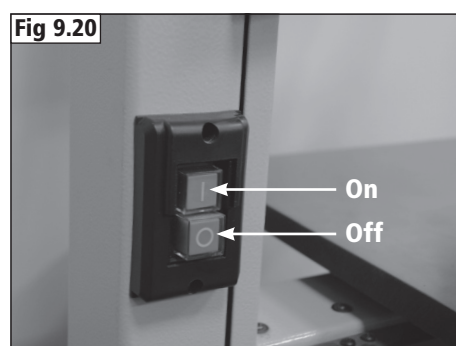
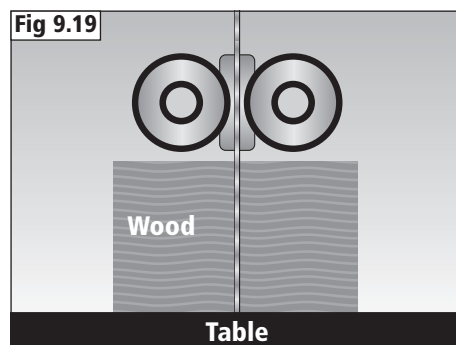
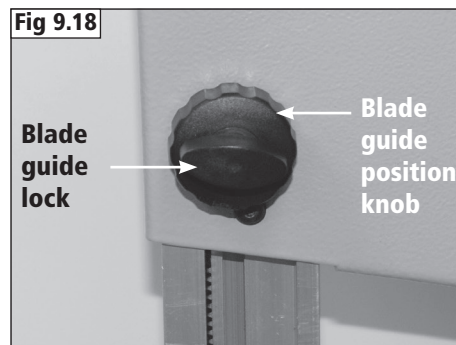
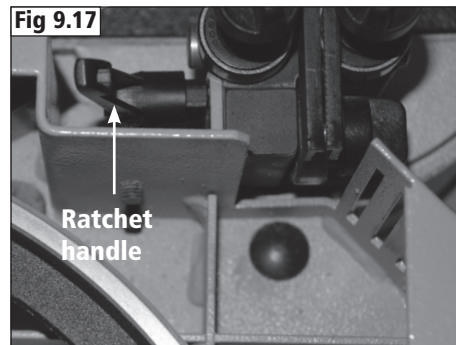
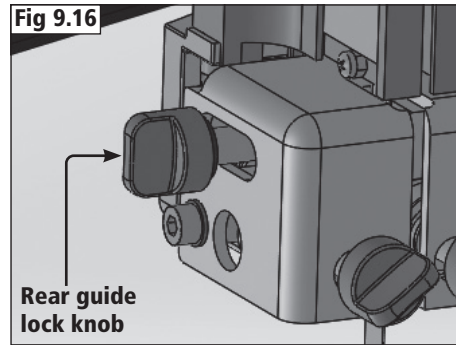

# 9. Operation and Bandsawing Practice

## Changing the Speed of the Bandsaw

The SABRE-250 can run at either 460 m / minute or 1000 m / minute. The higher speed is suitable for cutting wood and the lower speed is suitable for cutting non-ferrous metals.

Use a 6 mm hex wrench and loosen the drive belt tension nut and 2 washers located at the rear of the machine as shown in **Fig 9.21** and pivot the motor upwards, releasing tension on the drive belt, as shown in **Fig 9.22**.

To set the machine at the lower speed, position the drive belt on the lower band wheel pulley and motor shaft pulley as shown in **Fig 9.23**.

To set the machine at the higher speed, position the drive belt on the lower band wheel pulley and motor shaft pulley as shown in **Fig 9.24**.

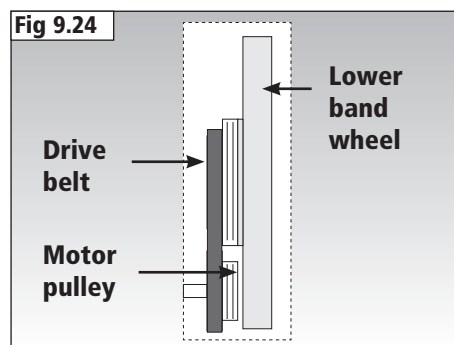
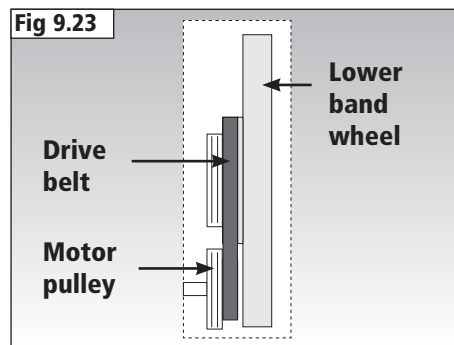
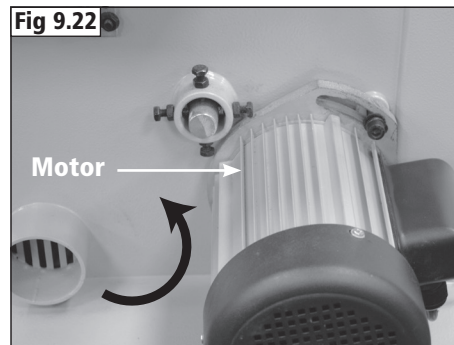
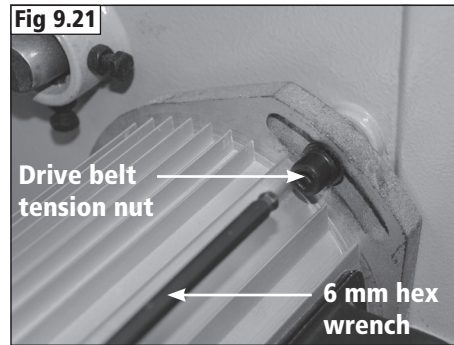

# 9. Operation and Bandsawing Practice

## Basic Bandsawing Principles

- The blade cuts on a continuous down stroke.
- Slowly feed the workpiece towards the blade, using only light pressure whilst letting the blade do the cutting. Always use a push stick and take care.
- Firmly hold the workpiece and feed it towards the blade slowly, using the push stick and keeping your hands well away from the blade.
- For best results the blade must be sharp. Damaged or worn blades should always be replaced.
- Select the correct blade for the job, depending on the thickness of the wood and the cut to be made (see blade selection).
- For straight cutting use the rip fence supplied.
- When cutting shapes, follow the design marked out by pushing and turning the workpiece evenly. Do not attempt to turn the workpiece without pushing it, as this may cause the workpiece to get stuck, or the blade to bend.



**CAUTION!** Particular care should be taken towards the end of the cut as there will be a sudden decrease in resistance and care must be taken to stop hands from being thrown towards the blade. Always use a push stick.

Always ensure that your machine is properly maintained and clean. Before commencing work on an important project, it is advisable to familiarise yourself with the operation of the equipment by practising on low value or scrap materials.



**WARNING!** In circumstances such as cutting deep or wet timber, the work piece may close up behind the blade causing it to stall. In the event that the blade stalls whilst cutting, ease the work piece backwards slightly, to release feed pressure from the blade. Allow the blade to reach full speed before continuing to feed the work piece in to the blade. If the blade fails to move when feed pressure is released, immediately switch off the machine and disconnect the power supply before attempting to free the blade from the work piece.



**WARNING!** If any component of the machine fails whilst in use or if the blade should break whilst the machine is running, immediately switch off the machine and disconnect from the power supply. Remove the faulty component and replace only with genuine Record Power replacement parts. Any electrical components should only be replaced by a suitably qualified person. To replace a broken blade, please refer to the section of this manual entitled "Band saw Blade Set Up". Always remember to fully release the blade tension mechanism before attempting to fit a new blade. If you are in any doubt about using the machine following a failure or if you need to order replacement spare parts or blades, please contact customer services in your country.

## Restarting

### In the Event of a Blockage or if the Machine Stalls

If the bandsaw stalls due to the blade becoming trapped in the work piece, switch it off immediately by pressing the stop button and wait for the machine to come to a complete stop before proceeding further.

If the blade is trapped within the work piece, it may be necessary to prise the work piece apart slightly using a suitable lever or wooden wedge in order to free the blade. If it is not possible to free the blade using this method, then it may be necessary to cut the blade using suitable side cutters or tin snips.

Replace the blade if necessary and ensure that it is correctly tracked and tensioned and that both doors of the bandsaw are fully closed and secured before attempting to re-start the machine.

To re-start the machine, press the green button marked 'I' on the switch.

### In the Event of a Power Failure

The bandsaw is fitted with a no volt release (NVR) switch to protect the user against automatic starting of the machine when power is restored after a power failure.

In the event of a power failure, first locate and rectify the source of the failure. If the fault is within the power circuit of the workshop, there may be an underlying cause (circuit overload etc.) that should be investigated by a qualified electrician, before attempting to restore the power source. If a cutting operation was taking place when the power supply was interrupted, then it may be necessary to free the blade from the work piece before attempting to re-start the machine.

Once the power is restored, the machine can be re-started by pressing the green button marked 'I' on the switch.

## Blade Selection (TPI)

The selection of the best blade configuration is necessary for optimum cutting performance.

- Correct blade choice is primarily dependant on two factors: material thickness and material type.
- Greater TPI should be selected as material thickness decreases.
- However, if the TPI is too great, the tooth loading will be insufficient to enable penetration; and cutting. The teeth will also rapidly lose their sharpness.
- For thicker material a lower TPI should be used otherwise the gullet will not be sufficient to clear the waste and the blade will stall or burn the wood.
- In general a minimum of 3 teeth should be in contact with the wood at all times during cutting.

The accompanying blade selection chart (see the table below) gives guidance on the TPI that should give the best results when cutting a variety of material types and thickness. The table below provides recommendations on selecting the correct blade for a variety of commonly used materials. If in doubt about any aspects of blade selection contact Customer Services in your country.

The table provides a guide to selection only. Exact tooth configurations are not always available, nor are all blade configurations covered, but the principles remain the same.

For special applications, custom blades can be supplied please call Customer Services in your country and we can advise you accordingly on your specific needs.

# 9. Operation and Bandsawing Practice

Material	Material Thickness			
	<6 mm	6-12 mm	12-25 mm	>25mm
Perspex	16 TPI	14 TPI	-	-
Chipboard	-	6 TPI	3-6 TPI	3-4 TPI
Fibre board	16 TPI	14 TPI	-	-
Hardboard	10 TPI	-	-	-
Plywood	10 TPI	8 TPI	6 TPI	3-4 TPI
Strawboard	14 TPI	10 TPI	-	-
Cork	14 TPI	6 TPI	3 TPI	3-4 TPI
Leather	14 TPI	-	-	-
Rubber	10 TPI	8 TPI	-	-
Wood -log	-	-	-	3-4 TPI
Wood -soft	6 TPI	3-6 TPI	3-4 TPI	3-4 TPI
Wood -hard	6 TPI	3-6 TPI	3-4 TPI	3-4 TPI
Wood -wet	-	-	-	3-4 TPI

### Blade Selection (TPI) - Cont.

Having selected an appropriate blade for the particular thickness and type of material to be sawn, it is essential that the saw blade is allowed to cut freely by not applying too much pressure.

- The need for excessive pressure is likely to be a result of the incorrect blade selection or a worn blade and will result in inaccurate cutting and possibly blade breakage.

### Blade Selection (Width)

- When cutting shapes, the width of the blade limits the minimum radius that can be cut.

- If the blade is too wide for the cutting radius the blade will twist and possibly jam or break.

- The smaller the radius the narrower the blade has to be.

The diagram below provides guidance on the minimum radius to be cut with the most commonly used blade widths.

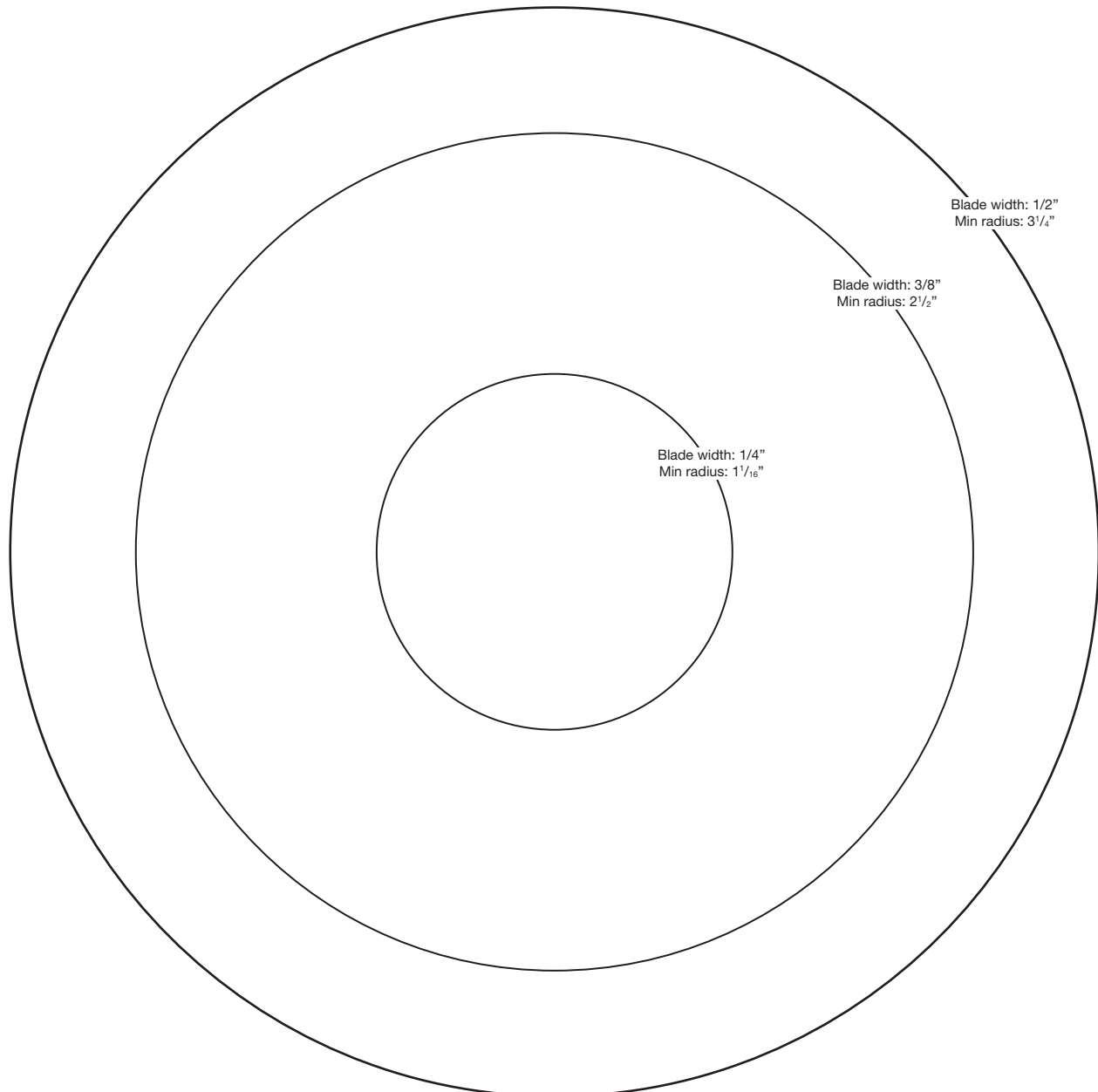

# 9. Operation and Bandsawing Practice

## Blade Selection Summary

To see how TPI and width of the blade come together, use the table opposite for reference.

- Regularly examine the blade for excessive damage or cracking as a result of fatigue. If such damage is present replace the blade.
- It is important to use a sharp blade. Dull teeth result in increased feed pressure producing a poor quality finish and an inaccurate cut.

<b>BB701406</b>	70 1/2" x 1/4" x 6 TPI Bandsaw Blad
<b>BB703804</b>	70 1/2" x 3/8" x 4 TPI Bandsaw Blade
<b>BB703806</b>	70 1/2" x 1/2" x 4 TPI Bandsaw Blade
<b>BB701206</b>	70 1/2" x 1/2" x 6 TPI Bandsaw Blade
<b>BB70-3PACK</b>	70 1/2" x 1/4" x 6 TPI Bandsaw Blade
	70 1/2" x 3/8" x 6 TPI Bandsaw Blade
	70 1/2" x 1/2" x 6 TPI Bandsaw Blade

**Note:** As well as the blades listed, we can also supply bandsaw blades to almost any specification please call Record Power Customer Services in your country.

### Record Power SABRE-250 Blade Range

Record Power's high performance bandsaw blades are manufactured to the highest quality tolerances using a specialist premium high carbon steel strip.

The extensive quality control program which involves digital tooth profile checks, set analysis, straightness testing, hardness testing and micro structural analysis results in a blade that cuts straighter and has harder, longer lasting teeth. A premium British blade that can last up to ten times longer than other blades on the market. To order any of these blades please contact Record Power Customer Services in your country who will advise you of your nearest retailer or alternatively a mail order supplier.

		Narrow Blade		Wide Blade	
		Application <b>TIGHT CONTOUR</b>	Application <b>MEDIUM CONTOUR</b>	Application <b>STRAIGHT CUT / LARGE CONTOUR</b>	
Coarse Blade ↑ ↓ Fine Blade	Material <b>Thick / Soft Timber</b>	Blade Spec width <b>1/4" (6.35 mm)</b> teeth <b>4 TPI</b>	Blade Spec widths <b>3/8" (9.5 mm)</b> teeth <b>4 TPI</b>	Blade Spec widths <b>1/2" (12.7 mm)</b> teeth <b>4 TPI</b>	
	Material <b>General Timber</b>	Blade Spec width <b>1/4" (6.35 mm)</b> teeth <b>4 - 6 TPI</b>	Blade Spec widths <b>3/8" (9.5 mm)</b> teeth <b>4 - 6 TPI</b>	Blade Spec widths <b>1/2" (12.7 mm)</b> teeth <b>4 - 6 TPI</b>	
	Material <b>Thin / Hard Timber</b>	Blade Spec width <b>1/4" (6.35 mm)</b> teeth <b>6 TPI</b>	Blade Spec widths <b>3/8" (9.5 mm)</b> teeth <b>6 TPI</b>	Blade Spec widths <b>1/2" (12.7 mm)</b> teeth <b>6 TPI</b>	

## Custom Jigs & Work Support

A bandsaw is one of the most versatile machines in the workshop and with careful preparation many problems encountered on a job can be overcome. By making and using custom jigs repetitive and accurate work can easily be achieved, the following illustrations are some examples of typical jigs and supports used on a bandsaw.

Ex. 1. Supporting large workpieces with roller stands or take off tables.

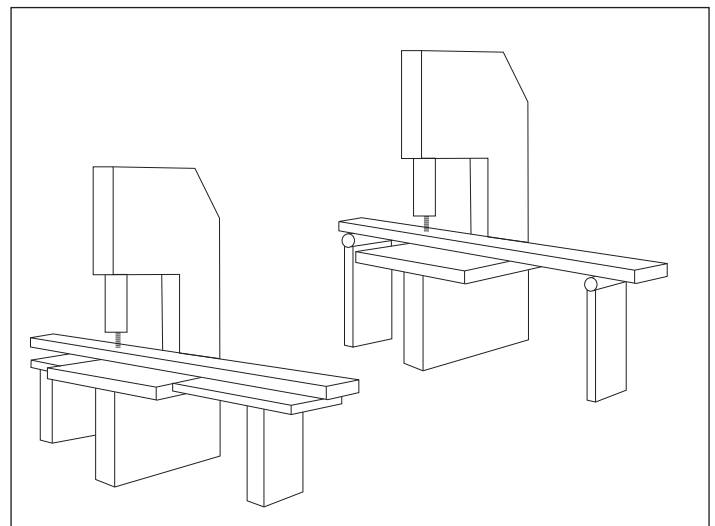

# 10. Maintenance



**Before carrying out any adjustments or maintenance ensure that the machine is isolated and disconnected from the electricity supply.**

## Replacing the Drive Belt

Release the blade tension by pulling the blade tension lever into the released position. Remove the bandsaw blade and loosen the drive belt tension. To loosen the drive belt tension, release the nut located at the rear of the machine and pivot the motor as shown in **Fig 10.1**.

Remove the drive belt from the motor pulley as shown in **Fig 10.2**.



**Warning: Wear eye protection when removing the circlip as it under tension.**

Remove the lower band wheel from the machine by removing the circlip located in the centre of the wheel, as shown in **Fig 10.3**.



**A set of circlip pliers is required to remove the band wheels.**

Once the circlip has been removed from the band wheel carefully pull the wheel from the shaft as shown in **Fig 10.4**.

The drive belt can now be removed and replaced. Place the new drive belt over the required band wheel pulley to select the desired speed, as shown in **Fig 10.5**.

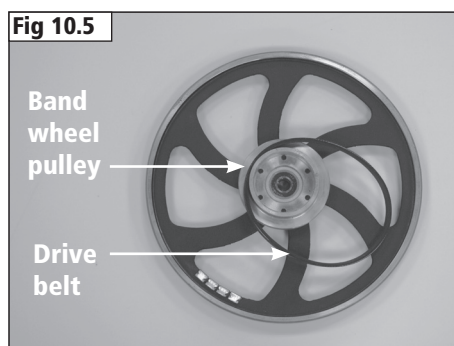
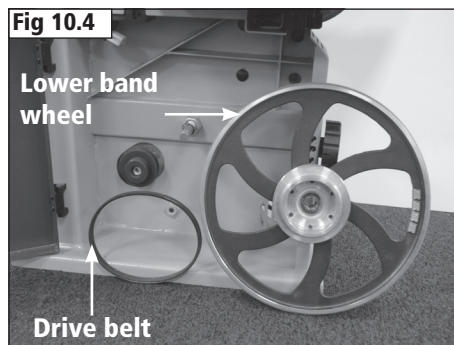
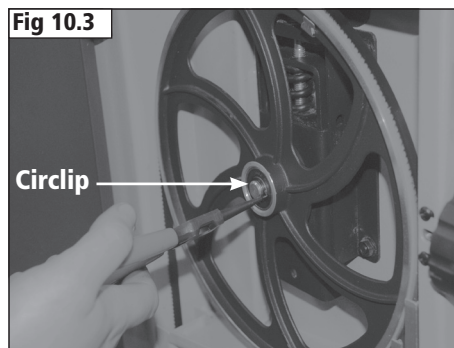
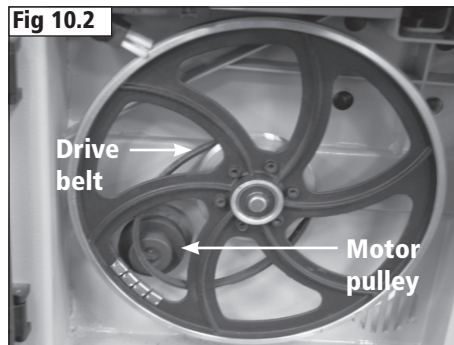
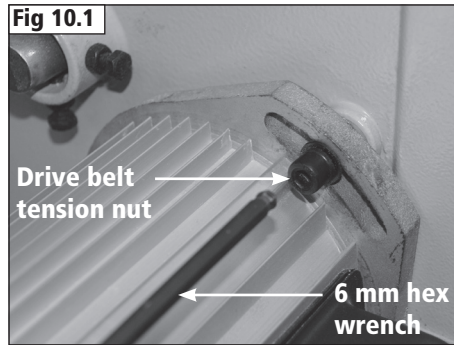

# 10. Maintenance

Ensure that the V grooves of the belt mate with the V grooves of the pulleys as shown in **Fig 10.6**.

Fit the drive belt onto the motor pulley and re-apply the drive belt tension.

The SABRE-250 can run at either 460 m / minute and 1000 m / minute. The higher speed is suitable for cutting wood and the lower speed is suitable for cutting non-ferrous metals.

To set the machine at the lower speed, position the drive belt on the lower band wheel pulley and motor shaft pulley as shown in **Fig 10.7**.

To set the machine at the higher speed, position the drive belt on the lower band wheel pulley and motor shaft pulley as shown in **Fig 10.8**.

## Replacing the Band Wheel Bearings

The bandsaw blade and wheels must be removed before replacing the bearings. To remove the band wheels follow the instructions in the section **Replacing the Drive Belt**.

The wheel hub located in the centre of the wheel contains 2 bearings which sit on a recess on the inside of the wheel hub. The bearings are held in place by 2 circlips on the inside, as shown in **Fig 10.9**.

Place the band wheel on 2 blocks of wood as shown in **Fig 10.10** and using a brass drift carefully tap out the bearings from the inside of the band wheel.

To re-fit, place the 2 circlips into the wheel hub at both sides, followed by the 2 new bearings. When re-fitting the 2 new bearings do not hit the centre race of the bearing as this could cause damage to the bearings.



**Knocking a bearing on the inner race that is a press fit on the outer race may cause instant damage to the bearing.**

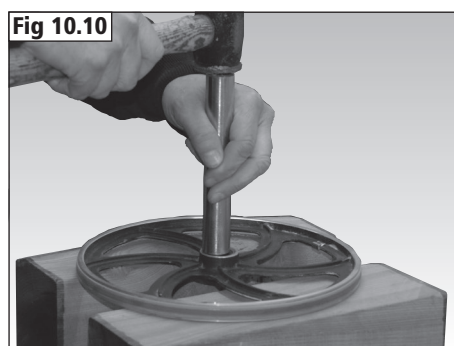
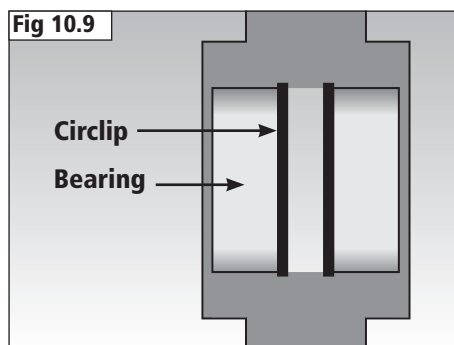
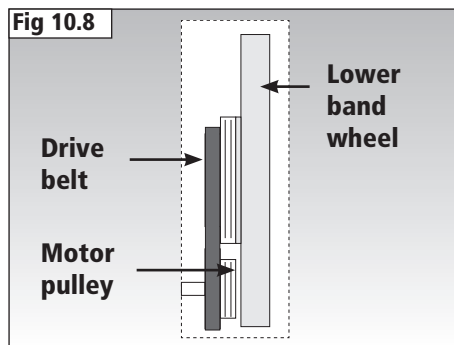
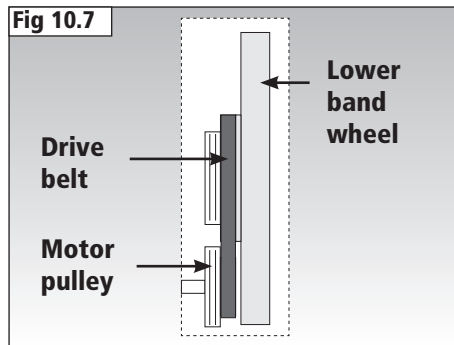
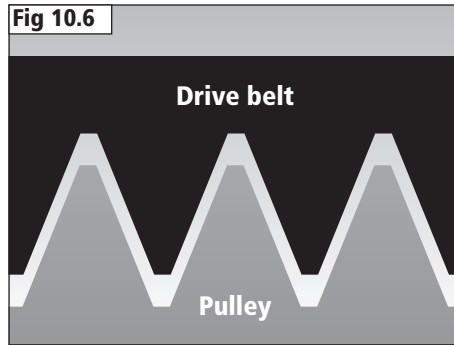



# 10. Maintenance

## Replacing Band Wheel Tyres

The band wheels have rubber tyres fitted to protect the teeth of the blade when in use and also provide grip to stop the blade slipping. Regularly inspect the tyres for wear and damage and replace if necessary.

Remove the blade from the bandsaw, followed by the wheel and ease the existing tyre from the rim, taking care not to damage the band wheel.

Clean the inside of the groove, removing any dirt or debris.

Place the new tyre in hot water to soften and expand it. Before fitment ensure that the tyre is warm but dry. This will make it easier to fit onto the wheel.

Carefully fit the new tyre over the wheel and ensure it is placed centrally on the rim over the full circumference of the wheel as shown in **Fig 10.11**.

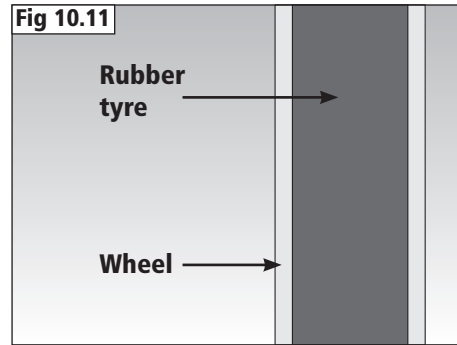

## Replacing Side Blade Guide Bearings

Fully unscrew the guide assembly lock knob and slide support shaft connecting the guide assembly to the guide post towards the front of the machine until the assembly is no longer attached to the guide post, **Fig 10.12** and **Fig 10.13**.

Once the assembly has been removed, fully unscrew the 2 hex head screws either side of the protective cover and remove along with the 2 spacers using a 4 mm hex wrench. Next, remove the side guide assembly by fully unscrewing the side guide lock knobs from the side guide bearings and remove. Next, remove protective cover from the guide assembly.

Remove the old bearings and replace with the new, ensuring the bearing bush, washer, bearings and sleeve are positioned as shown in **Fig 10.14**.

## Replacing the Rear Blade Guide Bearing

To remove the rear guide assembly fully unscrew the rear blade guide locking knob and remove the assembly as shown in **Fig 10.15**.

Remove the old bearing and replace with the new, ensuring the bearing bush, washer, bearings and sleeve are positioned as shown in **Fig 10.14** and the assembly is screwed back into the guide shaft.

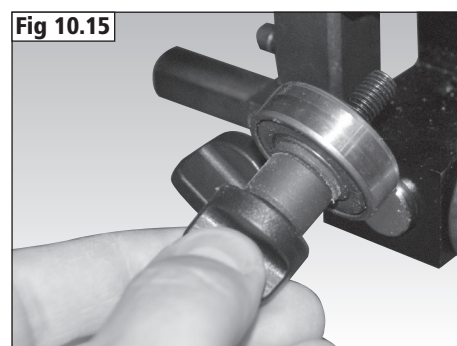
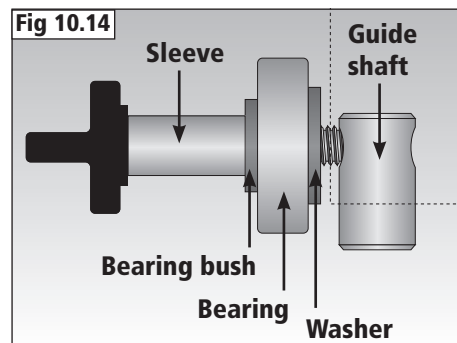
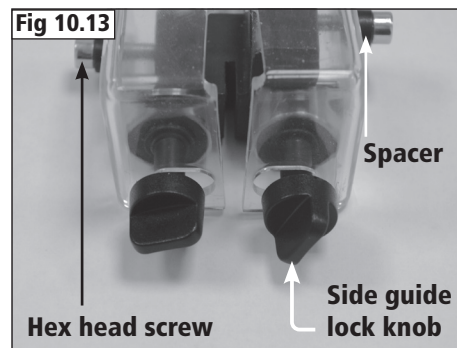
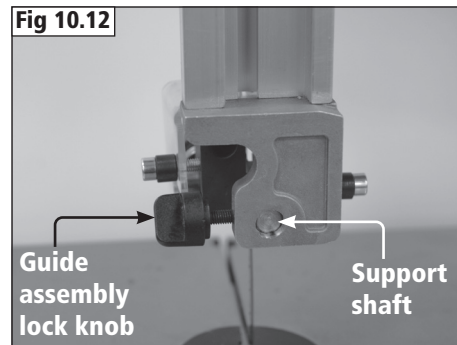

# 10. Maintenance

## Adjusting and Replacing the Band Wheel Brush

The band wheel brush is located in the lower band wheel box as shown in Fig 10.16.

The purpose of the band wheel brush is to remove sawdust that has been deposited during use.

To replace the band wheel brush, use a 13 mm wrench to remove the M6 nut and M6 x 25 bolt, located at the rear of the machine and replace the brush and re-assemble.

## Changing the Table Insert

The table insert, Fig 10.17, is designed to give support to the workpiece and be soft enough to not cause damage to the blade if contact is made. The table insert will need to be replaced periodically as it wears.



**Removing the blade before removing the table insert will eliminate the risk of injury from the blade.**

Push the table insert up and out from the underside of the table and fit the new table insert by pressing firmly down into place.

## Cleaning the Table

Regular cleaning of the table will ensure optimum performance of the machine. Remove all dust and resin using white spirit then coat the table with Record Power CWA195 Silicone Spray. The silicone spray will repel dust and resin, helping the timber to move freely on the table.

**Only apply silicone spray if you are sure it will not affect any surface finish that will be applied to your project afterwards.**

## Safety Devices

The machine is fitted with various safety devices which should be checked weekly to ensure that they function correctly.

## Micro-switch

The doors of the machine are fitted with interlocking micro-switches designed to stop the machine if the doors are opened when the machine is in use Fig 10.18.

Testing of the micro-switches is best done without the blade fitted to the machine.

To perform the test, first close both doors and start the machine. With the machine running, open the upper door. The machine should stop as the door is opened. If the machine fails to stop, the micro-switch may require adjustment or cleaning in order for it to work correctly. If the micro-switch is found to be faulty, then it must be replaced immediately with a direct replacement part.

Repeat the same test with the lower door.

Finally, with the machine switched off, open both the upper and lower doors, and attempt to start the machine. The machine should not start. If the machine does start, the micro-switches may be faulty and should be replaced immediately.

If either of the micro-switches is found to be faulty or defective, the machine must not be used until suitable replacement parts have been fitted and proved to be working correctly.

## Time Delay Screws

Both the upper and lower door knobs on the machine are fitted with Time Delay Screws, as shown in Fig 10.19. The time delay screws ensure that there is a delay in the opening of the door, allowing time for the machine to come to a complete stop, reducing the risk of injury to the user.

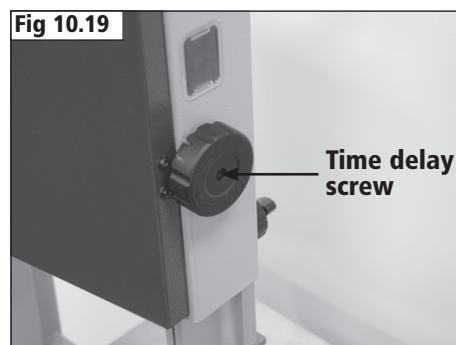
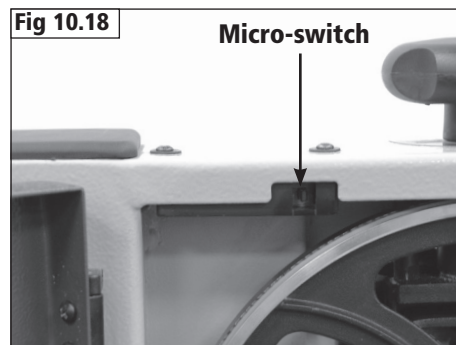
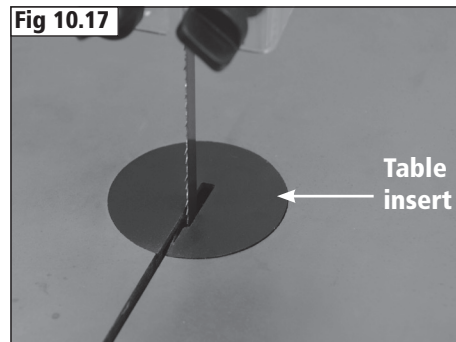
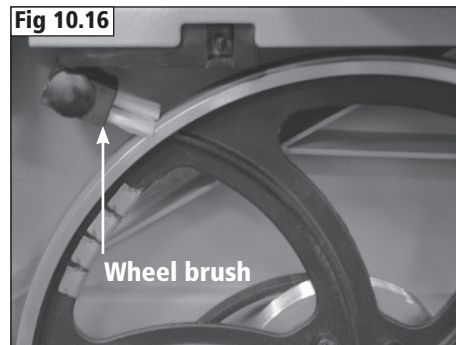

# 11. Dust Extraction

## The Importance of Dust Extraction

Suitable dust extraction is essential to avoid the possibility of serious health problems related to wood dust. It is also necessary in order to ensure the waste producing machine performs safely and effectively. Some woods are extremely toxic and in addition to suitable dust extraction machines it is recommended that PPE such as respirators are also used.

## Record Power Dust Extraction Machines

Below is a summary of the Record Power range. Please visit your local stockist or go online for full details.

### DX1000 Fine Filter 45 Litre Extractor

45 litre capacity, 1 kW motor, 0.5 micron filtration. Includes hose.

### RSDE1 Fine Filter 45 Litre Extractor

45 litre capacity, 1 kW motor, 0.5 micron filtration. Includes hose.

### RSDE/2 Fine Filter 50 Litre Extractor with Accessories

50 litre capacity, 1 kW motor, 0.5 micron filtration, includes wheel kit, hose cuff power tool adaptor hose and spare filter bags. Includes hose.

### RSDE/2A Fine Filter Auto-Switching 50 Litre Extractor with Accessories

50 litre capacity, 1 kW motor, 0.5 micron filtration, includes wheel kit, hose cuff power tool adaptor hose and spare filter bags. Includes hose.

### DX4000 Fine Filter Twin Motor 80 Litre Extractor

80 litre capacity, 2 x 1 kW motors, 0.5 micron filtration. Includes hose.

### DX5000 Fine Filter Twin Motor 200 Litre Extractor

200 litre capacity, 2 x 1 kW motors, 0.5 micron filtration. Includes hose.

### CGV286 CamVac Series Compact Extractor

36 litre capacity, 1 kW motor single or twin, 0.5 micron filtration.

### CGV286-WALL CamVac Series Wall Mounted Extractor

150 litre capacity, 1 kW motor single or twin, 0.5 micron filtration.

### CGV336 CamVac Series Medium Extractor

55 litre capacity, 1 kW motor single or twin, 0.5 micron filtration.

### CGV386 CamVac Series Large Extractor

90 litre capacity, 1 kW motor twin or triple, 0.5 micron filtration.

### CGV486 CamVac Series Heavy Duty Extractor

200 litre capacity, 1 kW triple motor, 0.5 micron filtration.

### CX2000 Compact Chip Collector

54 litre capacity, 0.56 kW motor. Includes hose.

### CX2500 80 Litre Chip Collector

80 litre capacity, 0.55 kW motor. Includes hose.

### CX3000 Heavy Duty Chip Collector

128 litre capacity, 0.56 kW motor. Includes hose.













































































### AC400 2 Stage Air filter with Remote, 3 speeds and Time Delay

Collects airborne dust, 1 micron filtration.

 Recommended for heavy use

 Recommended for light / intermittent use

 Can be used

	Bandsaws	Table Saws	Planer Thicknessers	Lathes	Sanding Machines	Dust Extraction Systems	Airborne Dust Collection
DX1000							
RSDE1							
RSDE/2							
RSDE/2A							
DX4000							
DX5000							
CGV286							
CGV286-WALL							
CGV336							
CGV386							
CGV486							
CX2000							
CX2500							
CX3000							
AC400							

# 12. Troubleshooting

Problem	Cause	Solution
Will not cut in a straight line.	<ol style="list-style-type: none"> <li>1. Blade is blunt.</li> <li>2. Blade guides set too high.</li> <li>3. Blade tension incorrect.</li> <li>4. Fence aligned incorrectly.</li> <li>5. Table aligned incorrectly.</li> </ol>	<ol style="list-style-type: none"> <li>1. Change blade.</li> <li>2. Adjust blade guides.</li> <li>3. Adjust blade tension.</li> <li>4. Align fence as shown in <b>section 8</b>.</li> <li>5. Align table as shown in <b>section 8</b>.</li> </ol>
Motor slows down during cutting.	<ol style="list-style-type: none"> <li>1. Too much pressure being applied.</li> <li>2. Drive belt slipping.</li> <li>3. Fence aligned incorrectly.</li> <li>4. Table aligned incorrectly.</li> <li>5. Wrong type of blade being used.</li> </ol>	<ol style="list-style-type: none"> <li>1. Adjust feed rate to suit material being cut.</li> <li>2. Adjust drive belt tension.</li> <li>3. Align fence as shown in <b>section 8</b>.</li> <li>4. Align table as shown in <b>section 8</b>.</li> <li>5. Change blade to a suitable type.</li> </ol>
Machine only operates when pressure is applied to the on switch.	<ol style="list-style-type: none"> <li>1. Faulty switch.</li> </ol>	<ol style="list-style-type: none"> <li>1. Replace switch.</li> </ol>
Machine buzzes but will not run.	<ol style="list-style-type: none"> <li>1. Motor capacitor is faulty.</li> </ol>	<ol style="list-style-type: none"> <li>1. Replace motor capacitor.</li> </ol>
Blade cannot be fitted.	<ol style="list-style-type: none"> <li>1. Blade tension not released.</li> <li>2. Blade is too small.</li> </ol>	<ol style="list-style-type: none"> <li>1. Release blade tension using the blade tension lever. Further tension reduction may be need to be performed using the blade tension knob.</li> <li>2. Ensure the correct length of blade is used.</li> </ol>
Blade cannot be tensioned sufficiently.	<ol style="list-style-type: none"> <li>1. Blade is too long.</li> </ol>	<ol style="list-style-type: none"> <li>1. Ensure the correct length of blade is used.</li> </ol>
Blade will not cut.	<ol style="list-style-type: none"> <li>1. Blade is upside down.</li> <li>2. Blade is back to front.</li> </ol>	<ol style="list-style-type: none"> <li>1. Ensure the teeth of the blade point downwards towards the bandsaw table.</li> <li>2. Ensure the teeth of the blade point towards the front of the machine.</li> </ol>
The bandsaw will not start.	<ol style="list-style-type: none"> <li>1. No power supply.</li> <li>2. Faulty switch.</li> <li>3. Doors not fully closed.</li> <li>4. Fuse blown.</li> <li>5. Faulty motor.</li> </ol>	<ol style="list-style-type: none"> <li>1. Ensure the machine is connected to a suitable power source.</li> <li>2. Replace the switch.</li> <li>3. Ensure both doors are fully closed.</li> <li>4. Replace the fuse.</li> <li>5. Replace the motor with a genuine Record Power motor.</li> </ol>
The bandsaw blade does not move when the motor is running.	<ol style="list-style-type: none"> <li>1. The blade is under insufficient tension.</li> <li>2. The blade has come off the wheels.</li> <li>3. The blade has broken.</li> <li>4. The drive belt has broken.</li> </ol>	<ol style="list-style-type: none"> <li>1. Ensure sufficient tension is applied to the blade.</li> <li>2. Re-fit the blade and ensure it is correctly tracked and tensioned.</li> <li>3. Replace the blade.</li> <li>4. Replace the drive belt.</li> </ol>
The bandsaw will not cut at 45° or 90° to the table.	<ol style="list-style-type: none"> <li>1. The table angle is incorrectly calibrated.</li> <li>2. The blade is blunt.</li> <li>3. Excessive pressure is being applied.</li> </ol>	<ol style="list-style-type: none"> <li>1. Set the table at 90° to the blade and re-set the angle pointer if necessary.</li> <li>2. Replace the blade.</li> <li>3. Reduce feed rate of the workpiece.</li> </ol>

# 13. Electrical Connection and Wiring Diagram

Machines supplied for use in the UK are fitted with a 3 pin plug conforming to BS1363, fitted with a fuse conforming to BS1362 and appropriate to the current rating of the machine.

Machines supplied for use in other countries within the European Union are fitted with a 2 pin Schuko plug conforming to CEE 7/7.

Machines supplied for use in Australia & New Zealand are fitted with a 3 pin plug conforming to AS/NZS3112.

In all cases, if the original plug or connector has to be replaced for any reason, the wires within the mains power cable are colour coded as follows:

230 V (Single Phase)

- Brown: Live (L)
- Blue: Neutral (N)
- Green and Yellow: Earth (E)

The wire coloured brown must always be connected to the terminal marked 'L' or coloured red.

The wire coloured blue must always be connected to the terminal marked 'N' or coloured black.

The wire coloured green and yellow must always be connected to the terminal marked 'E' or with the earth symbol:



or coloured green / green and yellow.

In the case of the BS1363 plug for use in the UK, always ensure that it is fitted with a fuse conforming to BS1362 appropriate to the rating of the machine. If replacing the original fuse, always fit a fuse of equivalent rating to the original. Never fit a fuse of a higher rating than the original. Never modify the fuse or fuse holder to accept fuses of a different type or size.

If a plug conforming to BS1363 is used, the combination of plug and socket shall be protected from water and dust to at least IP44.

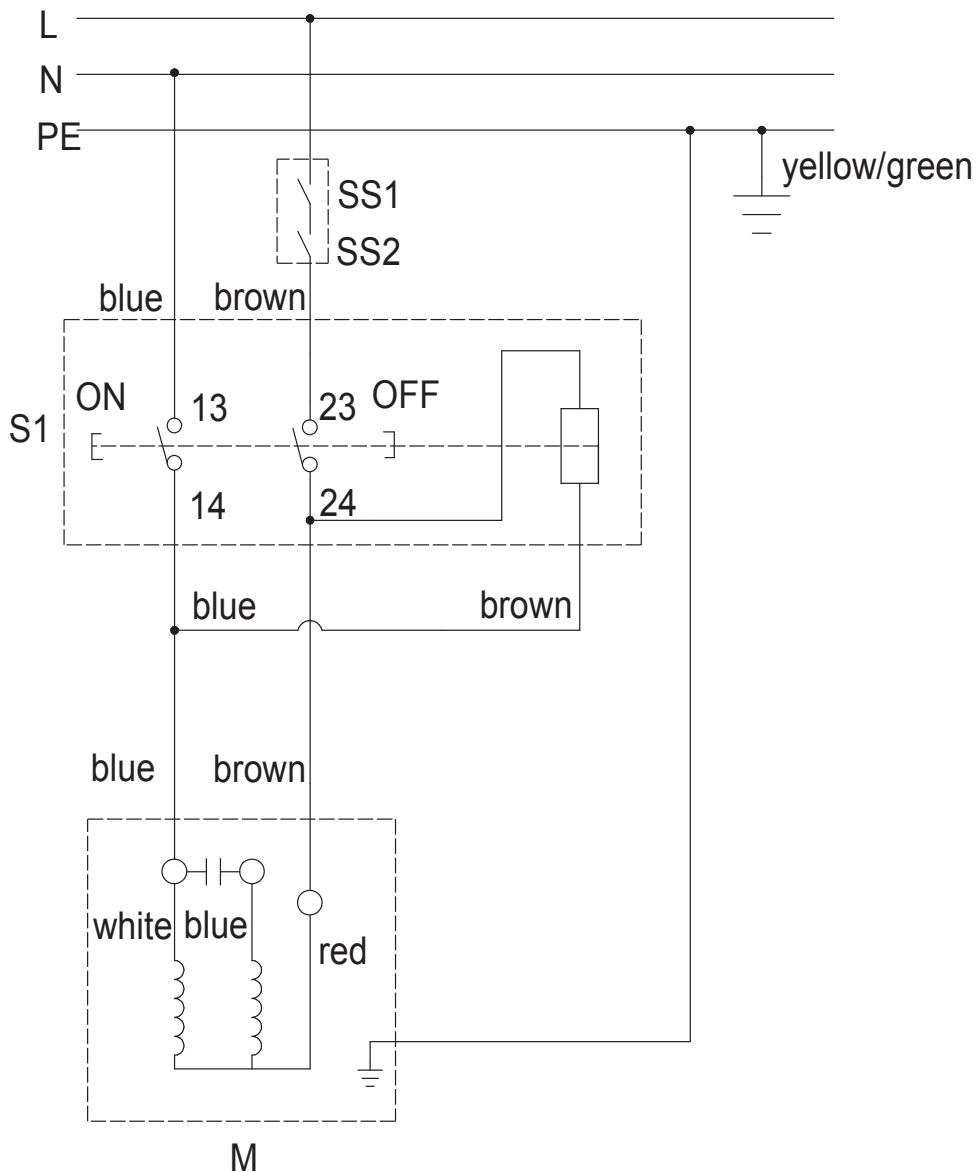

# 14. Parts Diagrams and Lists

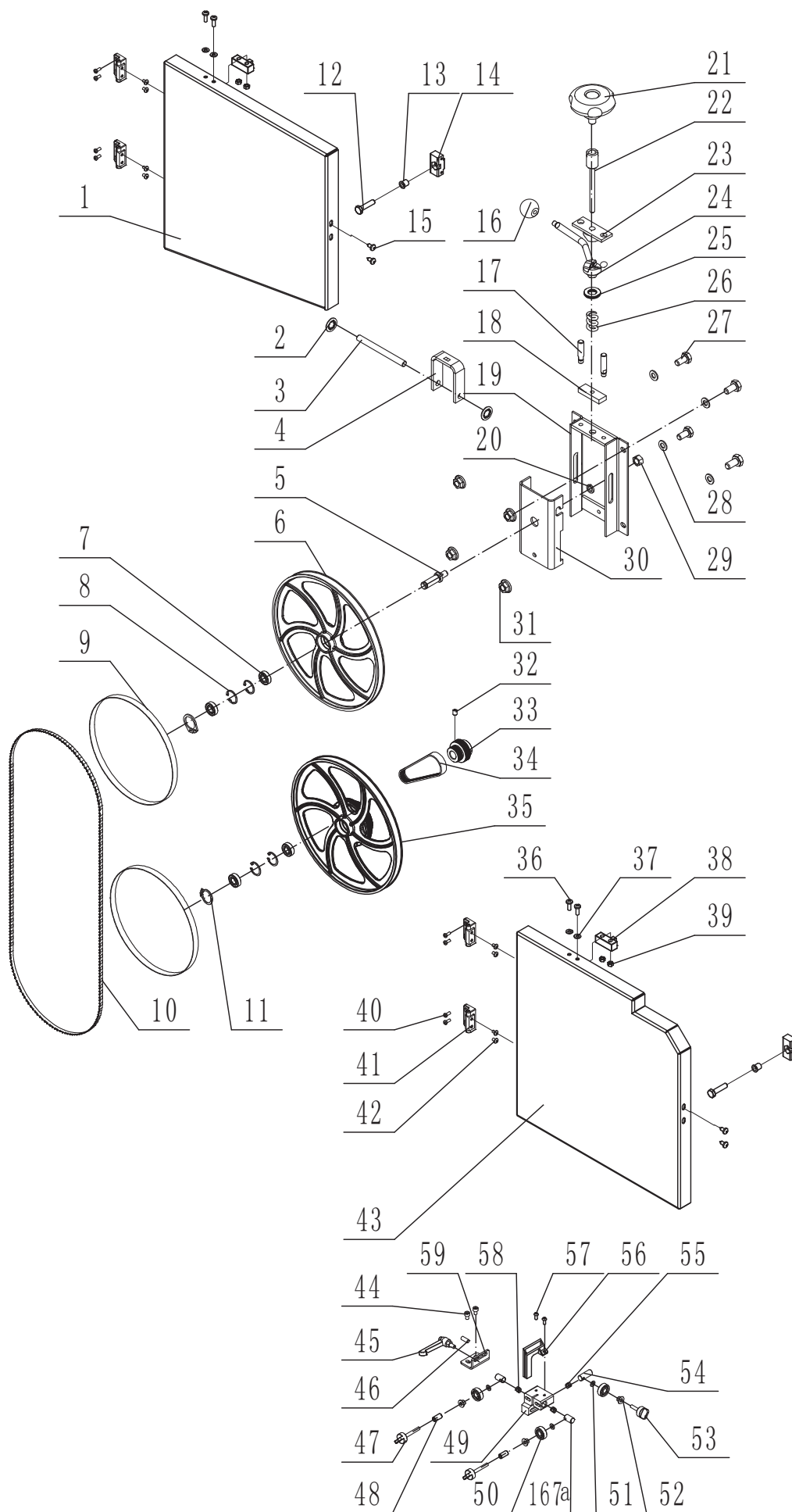

# 14. Parts Diagrams and Lists

No	Part number	Description	Qty	No	Part number	Description	Qty
1	1-JMBS1001013001B-053W	Upper door	1	47	1-JMBS1001051011-001S	Clamp handle	2
2	1-JL22021004	Retaining ring	2	48	1-JMBS1001050006	Bush	2
3	1-JL22021002	Mount shaft	1	49	1-JMBS1001012001B	Lower guide	1
4	1-JMBS1001041003-001Z	"U" Bracket	1	50	1-BRG608-2RSGBZ76	Bearing	6
5	1-JMBS1001041001	Upper wheel shaft	1	51	1-WSH5GB97D1B	Flat washer	3
6	1-JMBS1001021001-053Z	Upper wheel	1	52	1-JL20042002	Bearing bush	6
7	1-BRG6001-2RSGBZ76	Bearing	4	53	1-JMBS1001051007-001S	Locking handle	1
8	1-CLP28GB893D1B	Retaining ring 28	4	54	1-JMBS1001012002A	Adjusting spindle	1
9	1-JMBS1001020003	Tyre	2	55	1-JMBS1001051005	Spring 0.5	2
10	1-JL22020001A	Blade	1	56	1-JMBS1001010010	Lower guide cover	1
11	1-CLPT2GB894D1B	Retaining ring 12	2	57	1-M4X10GB70D2B	Screw	2
12	1-M6X30GB5783Z	Hex bolt	2	58	1-JMBS1001051004	Spring 0.5	4
13	1-JMBS1001015005	Rubber sleeve	2	59	1-JMBS1001010006-051W	Connecting plate	1
14	1-JMBS1001015004-001S	Adjusting pad	2	60	1-M8X70GB14B	Square neck bolt	1
15	1-ST4D2X9D5GB845B	Self tapping screw	4	61	1-JL22010006	Brush	1
16	1-JMBS1402040004-001S	Knob	1	62	1-M8GB6177D1B	Hex nut with flange M8	1
17	1-JMBS1001041010	Pilot pin	2	63	1-M4X10GB823B	Cross recess pan head screw M4X10	2
18	1-JMBS1001041004	Locking plate	1	64	1-KJD20-2	Switch	1
19	1-JMBS1001041100-001Z	Tension bracket	1	65	1-JL22090001-001S	Switch panel	1
20	1-WSH10GB93B	Spring washer	1	66	1-JMBS1001011000B-117U	Frame	1
21	1-JMBS1001043001-001S	Tension handle	1	67	1-V23752300A	Euro power plug	1
22	1-JMBS1001042000	Tension rod	1	67a	1-B33752300A	UK Power plug	1
23	1-JMBS1001041201	Upper cam wheel	1	68	1-JMBS1001010003A-001S	Plastic hanging board	1
24	1-JMBS1001041300	Lower cam wheel	1	69	1-M4X10GB819D1B	Cross recessed countersunk head screw M4X10	2
25	1-BRG1528AXKASGB4605	Axial needle and cage assemblies	1	70	1-JL22010001A-001S	Top cap	1
26	1-JMBS1001041002	Pressure spring	1	71	1-WSH8GB96D1B	Washer	1
27	1-M6X12GB5783B	Hex bolt	4	72	1-JL20010016-001S	Wing nut	1
28	1-WSH6GB97D1B	Flat washer	4	73	1-JMBS1403060003-001S	Handle	1
29	1-M10GB6170B	Hex nut M10	1	74	1-JL26090001	Tool holder	1
30	1-JMBS0901040008-001Z	Connecting plate	1	75	1-M5GB6170B	Hex nut M5	1
31	1-M6GB6177D1B	Flange nut	4	76	1-M5X25GB70D1B	Hex socket cap screw M5X25	1
32	1-M6X10GB78812D9	Hex socket set screw M6X10	1	77	1-M5X12GB70D1B	Hex socket cap screw M5X12	1
33	1-JMBS1001020002	Motor pulley	1	78	1-JMBS1001010004	Window	2
34	1-4P1394GB16588	Poly - V-belt	1	79	1-JL91046302	Strain relief nut	1
35	1-JMBS1001022100-053Z	Lower wheel	1	80	1-JL91046301	Strain relief	1
36	1-M4X12GB818B	Cross recess pan head screw M4X12	4	81	1-JMBS1001010005	Dust cover	1
37	1-WSH4GB97D1B	Flat washer	4	82	1-WSH8GB97D1B	Flat washer	2
38	1-JMBS0901010013-001S	Top plate	2	83	1-M8X30GB70D1B	Screw M8X30	1
39	1-M4GB6170B	Hex nut M4	8	84	1-WSH8GB93B	Spring washer	2
40	1-M4X10GB818B	Cross recess pan head screw M4X10	12	85	1-M8X30GB70D1B	Screw M8X30	1
41	1-JMBS1001013100	Hinge	4	86	1-JMBS1001020001	Lower wheel shaft	1
42	1-M4X6GB818B	Cross recess pan head screw M4X6	8	87	1-M6X20GB5783B	Hex bolt M6X20	4
43	1-JMBS1001014001B-053W	Lower door	1	88	1-M6GB6170B	Hex nut M6	4
44	1-M5X10GB70D2B	Screw M5X10	2	89	1-M14GB6171Z	Nut M14	1
45	1-KT5B-1-B-M6X50X10	Ratchet handle	1	90	1-CLP12GB894D1B	Retaining ring	1
46	1-M6X16GB77B12D9	Hex socket set screw with flat point M6X16	1	91	1-JL45060008	Washer	2
				92	1-M6GB6170B	Hex nut M6	1

# 14. Parts Diagrams and Lists

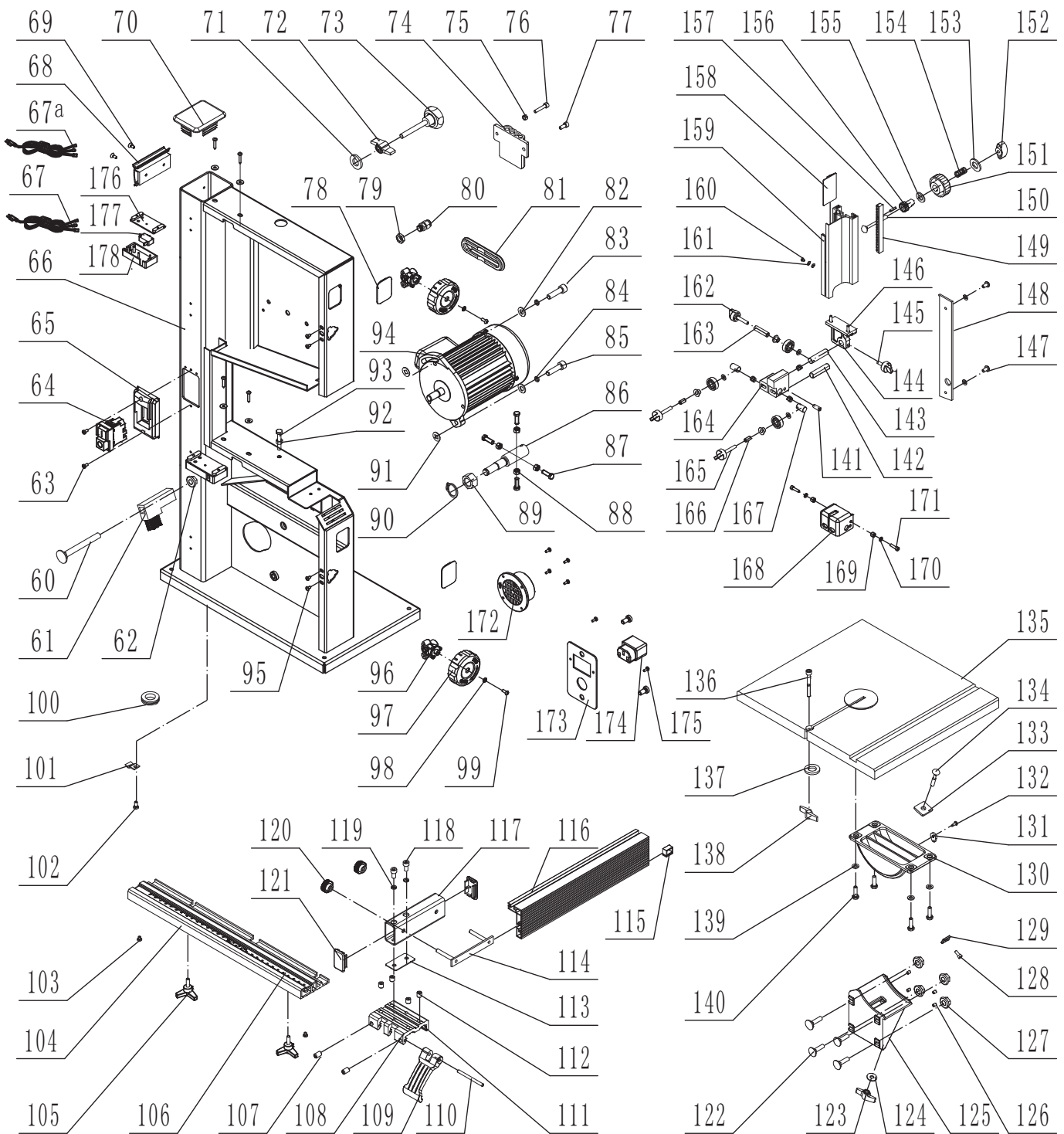



# 14. Parts Diagrams and Lists

No	Part number	Description	Qty	No	Part number	Description	Qty
93	1-M6X35GB5781B	Hex bolt M6X35	1	136	1-M6X30GB70D1B	Hex socket cap screw M6X30	1
94	2-YH710044A	Motor	1	137	1-WSH6GB97D1B	Flat washer	1
95	1-ST4D2X9D5GB845B	Self tapping screw	4	138	1-JL22020002-001S	Wing nut	1
96	1-JMBS1001015000A	Door lock assembly	2	139	1-WSH6GB862D2B	Washer	4
97	1-JMBS1001015100	Door knob	2	140	1-M6X12GB5783B	Hex bolt M6X12	4
98	1-W5H4GB862D2B	Washer	2	141	1-M6X16GB80812D9	Hex socket set screw with cup point M6X16	1
99	1-M4X10GB70D2B	Screw	2	142	1-JMBS1001051006	Support shaft	1
100	1-1905010	Rubber bushing	1	143	1-JMBS1001051003	Rear adjust shaft	1
101	1-1502014-02	Cable clamp	1	144	1-JMBS1001050002	Rear guide bracket	1
102	1-M5X10GB818B	Cross recess pan head screw M5X10	1	145	1-JMBS1001051009-001S	Clamp handle	1
103	1-M4X5GB818Z	Cross recess pan head screw M4X5	2	146	1-M4X16GB70D1B	Screw M4X16	2
104	1-JMBS1001060001	Guide rail	1	147	1-M5X10GB70D2B	Screw M5X10	2
105	1-JL60020023A	Star screw	2	148	1-JMBS1001010001	Locking plate	1
106	1-JMBS1001060007A	Scale	1	149	1-JMBS1001050001	Rack	1
107	1-JMBS1001060005A	Plastic screw	2	150	1-M6X50GB12B	Square neck bolt M6X50	1
108	1-JMBS1001060002	Fence carrier	1	151	1-JMBS0901050007A-001S	Height adjustment knob	1
109	1-JMBS1001060003-001S	Handle	1	152	1-JMBS0901050015-001S	Clamp handle	1
110	1-JMBS1001060006	Shaft	1	153	1-WSH6GB96D1B	Washer	1
111	1-JMBS1001060004	Plastic spacer	2	154	1-JMBS0901050016	Spring	1
112	1-JMBS1001060005B	Plastic screw	4	155	1-JL40020004	Washer	1
113	1-JMBS1001060008	Spacer	1	156	1-JMBS0901050005A	Wheel gear	1
114	1-JMBS1001060010	T-bar	1	157	1-PIN3X10GB879D1B	Roll pin	1
115	1-JMBS1001060013	Plastic pad	1	158	1-JMBS0901050010A-001S	Sliding plate	1
116	1-JMBS1001060009	Fence	1	159	1-JMBS1001050003	Blade guard	1
117	1-JMBS1001060011-001U	Block	1	160	1-M3X4GB818Z	Cross recess pan head screw M3X4	1
118	1-M6X12GB70D1B	Hex socket cap screw M6X12	2	161	1-WSH3GB97D1Z	Flat washer	2
119	1-WSH6GB93B	Spring washer	2	162	1-JMBS1001051010-001S	Clamp handle	1
120	1-JL20061003-001S	Nut	2	163	1-JMBS1001050005	Bush	1
121	1-JMBS1001060012-001S	End cap	2	164	1-JMBS1001051011-001S	Upper blade guide	1
122	1-M6X16GB14B	Square neck bolt M6X16	4	165	1-JMBS1001051011-001S	Clamp handle	2
123	1-JL22020002-001S	Ratchet Handle	1	166	1-JMBS1001050006	Bush	2
124	1-WSH6GB97D1B	Flat washer	1	167	1-JMBS1001051002B	Front adjust shaft	4
125	1-JL22030100	Support bracket	1	167a	1-JMBS1001051002	Front adjust shaft	2
126	1-M6GB6177D1B	Flange nut	4	168	1-JMBS1001050004	Protective cover	1
127	1-M5X6GB77B	Set screw M5X6	4	169	1-JMBS1001050007	Protective gasket	2
128	1-M4X10GB70D1Z	Hex socket cap screw M4X10	1	170	1-WSH5GB97D1B	Flat washer	5
129	1-JMBS1001031001-008S	Stopper	1	171	1-M5X20GB70D1B	Hex socket head screw	2
130	1-JMBS1001031002	Table trunnion	1	172	1-JMBS1001010011A	Dust port	1
131	1-1506003-01008S	Indicator	1	173	1-JMBS0901010012A-117U	Plate	1
132	1-ST3D5X9D5GB845B	Tapping screw	1	174	1-SS-120	IEC14 socket	1
133	1-JL22030002-001S	Sliding block	1	175	1-M3X10GB819D1B	Cross countersunk head screw	2
134	1-M6X35GB12B	Square neck bolt M6X35	1	176	1-JMBS0901010015	Micro switch cover	2
135	1-JL22031000B	Table	1	177	1-KW3-0Z-2B	Micro switch	2
				178	1-JMBS0901010016	Micro switch box	2



# EU Declaration of Conformity

**Cert No: EU / SABRE-250 / 1**

**Record Power Ltd,**

Centenary House, 11 Midland Way, Barlborough Links,  
Chesterfield, Derbyshire, S43 4XA, UK

declares that the machinery described:-

1. Type: **Bandsaw**
2. Model number: **SABRE-250**
3. Serial No .....

Conforms with the following directives:-

MACHINERY DIRECTIVE	2006/42/EC
ELECTROMAGNETIC COMPATIBILITY DIRECTIVE	2014/30/EU EN 1807-1:2013 EN60204-1:2006+A1:2009+AC:2010

and conforms to the machinery example for which the  
EC Type-Examination Certificate No. BM 50374938 0001  
has been issued by **TUV Rheinland LGA Products GmbH**  
at: Tillystrasse 2, D90431 Nürnberg

and complies with the relevant essential health and safety requirements.

Signed  ..... Dated: **01/05/2020**  
**Andrew Greensted**  
Managing Director



Over  
**100**  
years

Experience • Knowledge  
Support • Expertise

**RECORD POWER**  
ESTABLISHED 1909®

Woodworking Machinery and Accessories

Record Power Ltd, Centenary House, 11 Midland Way, Barlborough Links, Chesterfield, Derbyshire S43 4XA

Tel: +44 (0) 1246 571 020 Fax: +44 (0) 1246 571 030 [www.recordpower.co.uk](http://www.recordpower.co.uk)

To register a product and find your local stockist visit

**recordpower.info**

Made in China